

Qimarox®



User Manual
PRORUNNER mk9
Version 2.0 / 03-02-2016

Qimarox
Nobelstraat 43
3846 CE Harderwijk
The Netherlands

Tel: +31 341 436 700
Fax: +31 341 436 701
E-mail: info@Qimarox.com
Internet: www.Qimarox.com

Copyright © Qimarox B.V.

All rights reserved. No part of this publication may be reproduced, stored in a computer database or published in any form or in any way electronically, mechanically, by means of photocopying, recordings or in any manner without prior written permission from Qimarox.

Table of contents

1	About this manual	
1.1	Introduction.....	5
1.2	Product documentation.....	5
1.3	Source language	5
1.4	Symbols used in the manual	6
1.5	Terminology list	6
1.6	Further support and information	6
2	General	
2.1	Machine identification	7
2.2	Machine layout drawing and specifications	9
2.3	Warranty	9
2.4	Liability.....	10
2.5	CE Declaration of Conformity	10
3	Safety	
3.1	Intended use of the machine	11
3.2	User types and qualifications.....	11
3.3	Safety instructions	11
3.4	Safety equipment.....	12
3.5	Potential risks	14
3.6	Machine end of life and environment disposal	15
4	Description	
4.1	Working principle	17
4.2	Sensors	19
4.3	Motor	20
4.4	Control	21
4.5	Machine in a system.....	21
4.6	Specifications	22
4.7	Application information	23
5	Installation	
5.1	Location	24
5.2	Delivery.....	25
5.3	Transport	26
5.4	Unpacking.....	26
5.5	Preparations for a Qimarox installation (optional)	27
5.6	Installing the machine	27
5.7	Installing the moveable conveyor	32

6	Maintenance	
6.1	Specific safety regulations.....	34
6.2	Preventive maintenance schedule.....	35
6.3	Cleaning	37
7	Troubleshooting	
7.1	Vertical conveyor	38
8	Exploded views	
8.1	Frame parts	41
9	Electrical circuit diagrams	
9.1	Drives	55
9.2	Installing 87Hz	55
10	Pneumatic circuit diagrams	
10.1	Mechanical locking device.....	57
11	Appendix	
11.1	Product registration form	58

1 About this manual

1.1 Introduction

This manual provides information about the PRORUNNER mk9 machine, which is used for the vertical movement of products within a transport system. From here in the manual, the PRORUNNER mk9 will be referred to as the “machine”.

This manual is intended for:

- Retailers/Original Equipment Manufacturers (OEM) project engineers and mechanics.
- Operator, installation and maintenance engineers and other users.

It is important to carefully read this manual as soon as possible after purchase of the machine.

Before you operate the machine, this manual should be read by all users. This is necessary to make sure that all new users are familiar with the content of this manual.

System integrators/OEMs

This manual explains machine configurations you can use to setup the machine. It also provides instructions on how to add or change the machine technical components.

Users

The machine may be supplied pre-assembled, if so, some chapters in this manual will not be applicable. To integrate the machine within a transport system, Qimarox advises you to refer to documentation provided by the OEM of the transport system.

1.2 Product documentation

Document	Reference
Machine manuals ¹	UM-PRORUNNER_mk9-2.0-EN
Machine layout drawing ²	Refer to section 2.2.
Electrical diagrams ¹	
Specification sheet ²	
OEM parts of the machine: <ul style="list-style-type: none"> • Bolts and nuts • Motor reductor • Photocells • Runners • Chain • Induction switches • Limit switches • Belts 	

1 Generic information for each machine, apart from exceptions outlined in the machine layout drawing.

2 Machine specific information.

1.3 Source language

This manual was originally written in the English language.

1.4 Symbols used in the manual

The following symbols are used in this manual.



WARNING

Risk of serious injury to the user or damage to the machine if the instructions are not accurately followed.



Note

To provide additional information to the user about a task or issue.

1.5 Terminology list

The table below explains common terms used by Qimarox for the machine.

Term	Definition
machine	The PRORUNNER mk9.
product	Products transported by the machine.
carrier	The component on which a conveyor can be mounted or which carries the product.
feeding conveyor	The conveyor that delivers products to the machine. The feeding conveyor is not part of the machine.
discharge conveyor	The conveyor that discharges products from the machine. The discharge conveyor is not part of the machine.
fenced area	Area around the machine that unauthorised personnel cannot enter for safety reasons.

1.6 Further support and information

Qimarox can supply additional expertise and support services, for:

- Training
- Global support
- Service contracts

For more information please contact Qimarox.

2 General

2.1 Machine identification

The machine identification is given on the type plate. The type plate is located on the side of the column.

The machine type on the identification plate has a code consisting of 7 parts (A - G). This indicates in detail which machine configuration is involved.

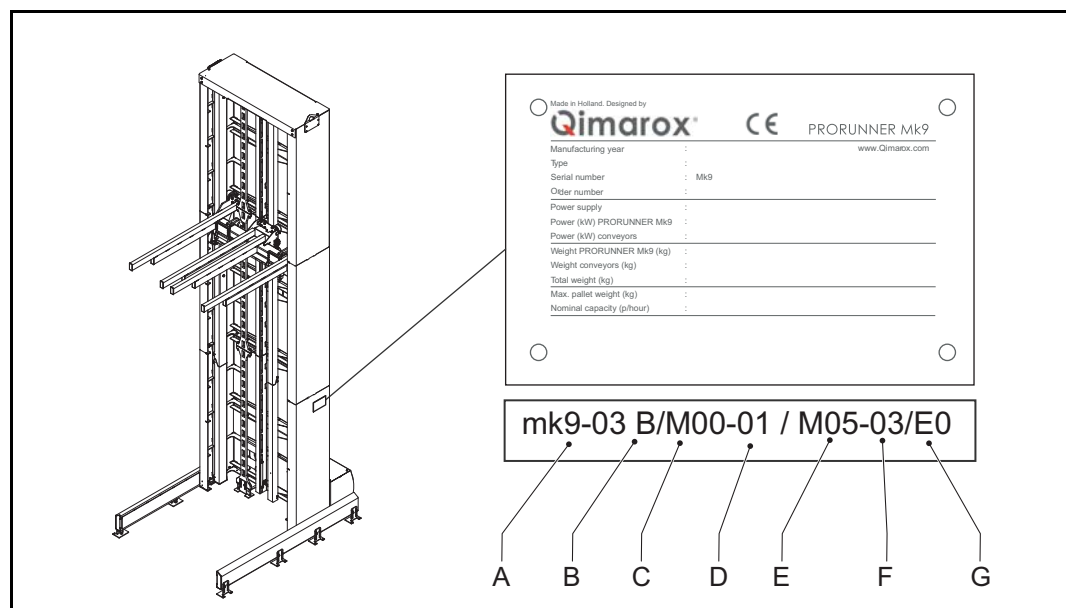

- A type of drive
- B type of column
- C type of product conveyor moveable
- D type of drive for product conveyor moveable
- E type of product conveyor fixed position
- F type of drive for product conveyor fixed position
- G type of E-components

Column type:

- KS Standard column

Carrier type:

- DB Carrier with conveyor
- DZ Carrier without conveyor

Fixed position type:

- UV Fixed outfeed conveyor

Code part	Remark	Possible value	Meaning of the value	Type	Refer to chapter
A	Drive type	00	None / not supplied	11	
		05	3 Phase ~ + BR + TF		9.1
		11	3 Phase ~ + BR + TF + encoder		9.1
		99	Other		
B	Column type	S	Column without sensors, no encoder on carrier	B	
		B	Column with sensors, no encoder on carrier		
		E	Column with sensors and encoder on carrier		
C	Conveyor in elevator type	000	None / not supplied	000	
		F01	Fork		
		M01	Roller conveyor		
		M02	Roller chain conveyor		
		999	Special version		
D	Conveyor in elevator drive	00	None / not supplied	00	
		03	3 Phase ~		9.1
		05	3 Phase ~ + TF		9.1
		06	3 Phase ~ + BR		9.1
		07	3 Phase ~ + BR + TF		9.1
		99	Special version		
E	Fixed conveyor type	000	None / not supplied	000	
		M01	Roller conveyor		
		M02	Roller chain conveyor		
		999	Special version		
F	Fixed conveyor drive	00	None / not supplied		
		03	3 Phase ~		9.1
		05	3 Phase ~ + TF		9.1
		06	3 Phase ~ + BR		9.1
		07	3 Phase ~ + BR + TF		9.1
		99	Special version		
G	E-component out-feed type	E0	None / not supplied		
		E1	24 VDC IP66		
		E2	24 VDC IP67		
		99	Other		

2.2 Machine layout drawing and specifications

After a machine order is placed, you will receive a machine drawing and specifications sheet for approval. After your approval you will receive an approved drawing and specification sheet which is used as a reference for this manual.

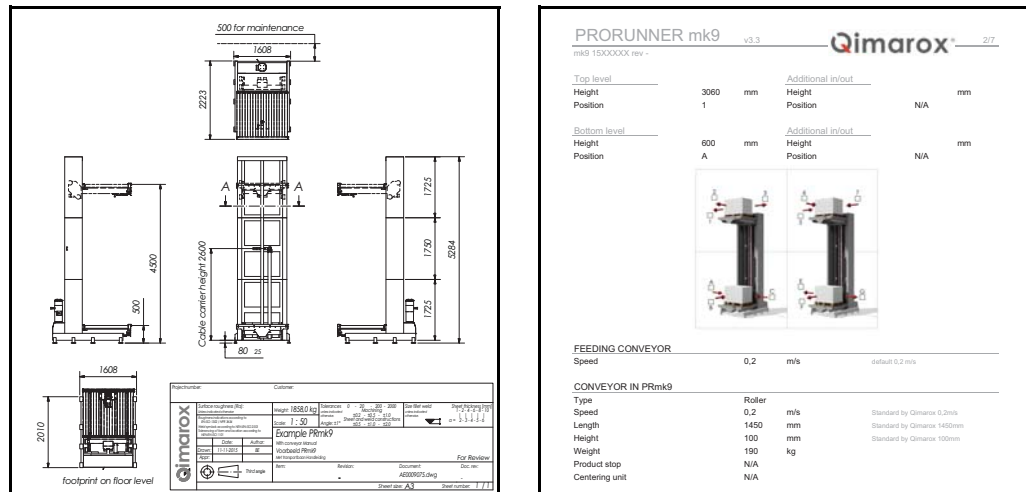

This drawing and specifications sheet includes:

- Machine serial number
- Product dimensions and mass
- Machine dimensions and mass
- Machine configuration
- Machine speed and capacity
- Motor specifications

The machine can only be used according to the specifications given in this manual and the machine layout drawing specifications. If you want to use the machine outside the recommended specifications, you must contact Qimarox to check if this is possible. Inappropriate and/or modified use of the machine can result in dangerous safety issues and/or damage. You must obtain written confirmation from Qimarox before using the machine in a modified or unspecified manner. Qimarox cannot be held liable for any accidents and/or damages that may occur through inappropriate unauthorised use of the machine.

2.3 Warranty

The scope and duration of the warranty is agreed when an order is placed for the machine.

The warranty only applies if the machine is used according to the specifications and if the user and maintenance instructions are observed.

The warranty does not cover wear of the parts.

The machine warranty is null and void in cases of:

- Unskilled use.
- Inadequate maintenance.
- Unskilled maintenance.
- Modifications made to the machine without prior written permission from Qimarox.

2.4 Liability

Qimarox believes to the best of its knowledge that the information in this user manual is accurate. In the event that technical or typographical errors exist, Qimarox reserves the right to make changes to subsequent editions of this user manual without prior notice to holders of this edition. The reader should consult Qimarox if errors are suspected. In no event shall Qimarox be liable for any damages arising out of or related to this user manual or the information contained in it. Except as specified herein, Qimarox makes no warranties, express or implied, and expressly disclaims any warranty of non-infringement, merchantability or fitness for a particular purpose. Customer's right to recover damages caused by fault or negligence on the part of Qimarox shall be limited to the amount paid to Qimarox by the customer. Qimarox shall not be liable for damages resulting from loss of data, profits, use of products, or incidental or consequential damages, even if advised of the possibility thereof. This limitation of liability of Qimarox will apply regardless of the form of action, whether in contract or tort, including negligence. Any action against Qimarox must be brought within one (1) year after that cause of action accrues.

Qimarox is not liable for damages, accidents, unsafe conditions, defects, malfunctions, or service failures caused by the following:

- Owner's or user's failure to follow Qimarox's installation, operation and maintenance instructions, including but not limited to neglecting warnings or regulations as shown on the machine or in this manual.
- Usage of the machine for other applications, or under other circumstances than indicated in this user manual. This includes abuse, misuse or negligent acts.
- Modifications of any kind to the machine. This includes the replacement of parts with parts that are not specified in this manual.
- Insufficient or improper maintenance.

2.5 CE Declaration of Conformity

For the CE declaration of conformity, refer to the specification sheet.

3 Safety

3.1 Intended use of the machine

The machine is exclusively intended for the vertical transportation of products, as described in this manual. Refer to section 4.6 for a detailed description of the specifications of use.

The machine is always set up within a larger transport system in which products are automatically loaded on and off the machine.



WARNING

Any other use of the machine is strictly forbidden.

3.2 User types and qualifications

The following user types are referred to in this manual:

- The operator.
- The mechanical installer.
- The electrical installer.
- The maintenance engineer.

All users must be familiar with the full content of this manual.

Only qualified personnel is permitted to operate, install or maintain the machine.

A user is only qualified if the user has attended appropriate training and/or attained appropriate industry standard recognized qualifications. Qimarox can provide training if required.

Qimarox can also give advice about actions and tasks to be carried out on the machine.

3.3 Safety instructions

3.3.1 General

- Comply with the safety regulations given in this manual. Deviation from these regulations can lead to unacceptable risks.
- Never close doors (if present) in the fenced area of the machine, when a person is inside this area.
- Switch off the machine and secure the main power supply switch in the off position with a padlock to prevent the machine from being switched on while personnel works within the fenced area.
- Comply with all relevant local legislation and regulations.

3.3.2 Set up

- Connect the machine in accordance with the local laws and regulations concerning health and safety.
- Before putting the machine into use, check if the machine has been set up in accordance with the instructions in this manual and with the layout drawing.
- Make sure that the transport system complies with all relevant health and safety directives and regulations.

3.3.3 Start the machine

- Do not switch the main power supply on when persons are in contact with the machine.
- Do not start the machine when persons are in contact with the machine.
- Do not start the machine when persons are present in the fenced area of the machine.
- Before the machine is put into operation, all machine parts must comply with all relevant health and safety directives and regulations.

3.3.4 During machine operation

- Keep your hands and feet away from the fenced area.
- Make sure you do not wear loose clothing and secure long or loose hair.
- Make sure that no persons or objects are within the range of any moving parts of the machine.
- Make sure that users know and observe all safety rules with regard to the machine and the environment in which it operates.

3.3.5 Maintenance and repair

- Turn off the power supply to the machine with the main power supply switch before starting any maintenance or repair tasks. Secure the main power supply switch in the off position with a padlock.
- Replace damaged or defective parts before putting the machine back into operation.
- Changes and modifications that may affect the safety of the machine can only be carried out when these changes and modifications comply with the relevant regulations, legislation, directives and recognized industry standards.
If changes and modifications are outside the scope of specifications given by Qimarox in this manual and Qimarox has not granted permission changes and modifications, then the changes and modifications will entirely be the responsibility of those persons responsible for carrying out the changes and modifications.
- Electrical installation tasks must only be carried out by qualified personnel.

3.4 Safety equipment

- You must not disassemble, bypass or disable any safety equipment on the machine.
- The machine may not be started and must be immediately taken out of operation if even a single item of machine safety equipment is defective.
- After maintenance tasks are complete, always replace all safety equipment that has been removed from the machine.

The machine has been equipped with the following safety equipment:

- Safety pressure valve (pneumatic system for mechanical locking device)
- Mechanical locking device
- Panels on the backside of the machine

**Note**

Replace labels on the machine if they become unreadable or damaged.

A fenced area around the machine is mandatory for personnel safety. Any access doors must be secured with (interlock) door switches. These switches must be included in the emergency stop and safety circuit. Refer to section 3.4.1 for information about how to set up the fenced area.

In case of non-compliance with the required safety measures, the CE Declaration of Conformity will become null and void.

3.4.1 Safety fence

The fenced area must comply with EN ISO 13857 and EN 619 standards.

The infeed and outfeed openings of the machine must be designed such, that they protect persons against reaching the danger zone. When this is not possible, these openings must be equipped with a light curtain.

Make sure that the fenced area complies with local law and rules for protection against danger. If the fenced area is fitted with a door, it must have a safety switch to shut down the system when opened. Refer to 3.4.2.

If Qimarox supplies the safety fencing, the specifications will be included in the machine layout drawing.

**WARNING**

If the machine moves the products through a floor to another level, apply safety measures to all levels.

3.4.2 Safety controls

The provisions must be designed according to a so-called Performance Level (PL) corresponding with the current standard for safety functions of a machine or a machine control in compliance with EN ISO 13849-1:2008. To the machine a PL_d applies, in which d indicates that the risk must be substantially reduced.

Emergency stop circuit

The machine must have an emergency stop circuit. When one of the emergency stop buttons is pressed, the main power and the control current of the machine are switched off immediately.

Set the motor protection relay

Motor protection devices must be set to the nominal motor current. A relay set too low prevents optimum use of the motor. A relay set too high does not guarantee full thermal protection.

When a correctly set relay trips too often, reduce the load of the motor or use a larger motor.

Thermistor protection (TF contact)

For motors that are frequently started and stopped, intermittently operated, use a high switching frequency or power controller, it is essential to use a motor protection relay and thermistor protection. This is to avoid prematurely switching the motor protection relay or overheating of the motor winding in these operational conditions.

Check continuously moving of products

It is necessary to check if the products are continuously moving during transport to the infeed and outfeed position by means of time monitoring in the software. When the time is exceeded, the machine must immediately stop to avoid damage.

Mechanical locking device

The machine is equipped with a mechanical locking device which protects the carrier from falling down if the flat belts break or are being released. The mechanical locking device must also be released in all other circumstances that personnel safety is at risk. This device is installed for personnel safety and can not be used as fall protection during operation. For detailed information about the safety valve that controls the release of the mechanical locking device, refer to the manual of the supplier.

3.5 Potential risks

The machine is intended to be integrated into a transport system. Qimarox has attempted to protect against as many hazards as possible. The following potential risks should be addressed before machine and assembled parts are put into operation:

- Risk of injury caused by falling products.
- Risk of injury as a result of a moving carrier.
- Hazards occurring at places where the machine connects to other parts of the production line, such as feeding and discharge conveyors.

The interior of the machine can be accessed by removing the back covers or directly from the front. Additional protection (fencing) is required at the feeding and discharge position.

If the machine is accessible from multiple levels, then protection measures should be taken to avoid hazards. Please note that additional, local rules or laws may be applicable and require you to take additional measures.

3.6 Machine end of life and environment disposal

Proper use and maintenance of the machine will not involve any environmental risks. After the machine is no longer useable, the machine should be dismantled and disposed of in an environmentally responsible manner.



WARNING

Observe all relevant legislation, regulations, instructions and precautions with regard to health and safety when dismantling the machine.

Observe all relevant legislation, regulations, instructions and precautions with regard to the disposal of products in the environment.

4 Description

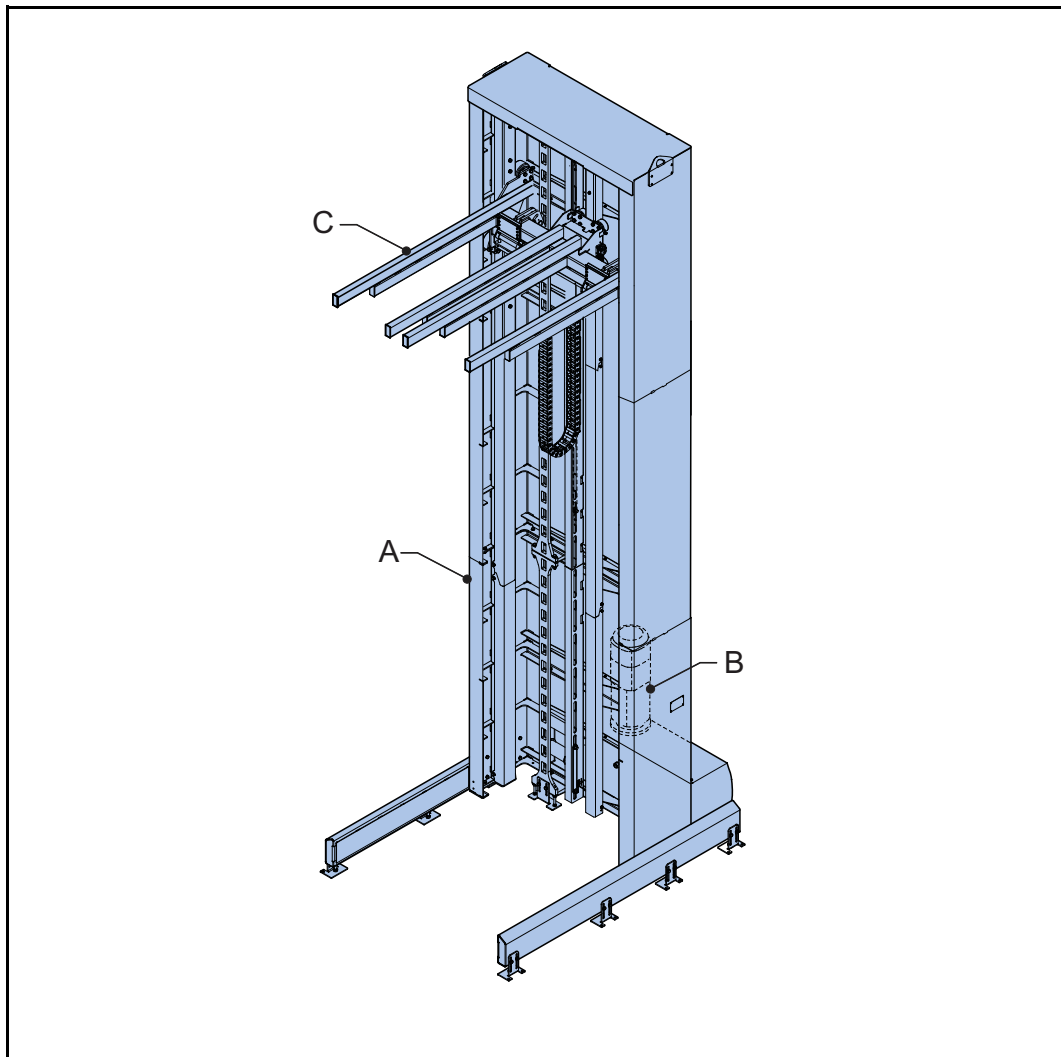

- A Column
- B Drive section
- C Carrier

The machine is designed to vertically transport a product from one to another level.

The machine consists of a column, a moveable carrier and a drive section. The carrier is suspended by two flat belts which are wound up by a motor located in the drive section. The carrier is guided by wheels running over guiding profiles in the column. For safety reasons the machine is equipped with a mechanical locking device, preventing any downward movement of the carrier when the safety circuit is triggered.

4.1 Working principle

4.1.1 Guiding the carrier

- A Wheel
- B Guiding profiles
- C Adjusting bolts
- D Wheel
- E Adjusting bolts

The wheels of the carrier are running over the guiding profiles of the column.

The carrier can be leveled:

- To tilt the carrier forward or backwards, adjust the position of the wheels (A) by adjusting the bolts (C).
- To tilt the carrier sideways, adjust the position of the wheels (D) by adjusting the bolts (E).

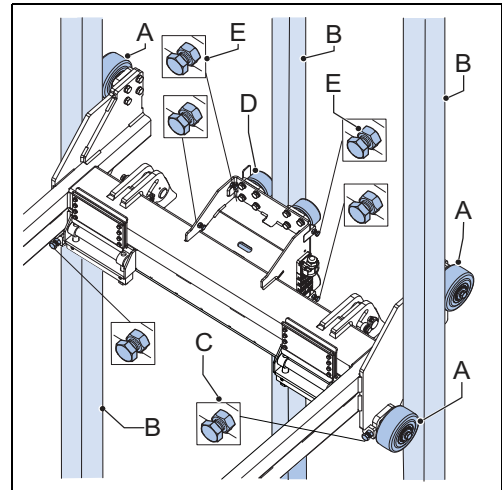

4.1.2 Suspension of the carrier

- A Adjusting bolts
- B Detection block
- C Sensor belt on tension

Both hoisting belts must be tensioned equally. This can be achieved by loosening or tightening the adjustment bolts.

When one or both detection blocks are not detected by sensors, an emergency stop must be triggered. Possible causes are:

- There is something below the carrier, where the carrier rests on.
- One of the (attachment points of the) flat belts failed.
- There is an electrical error.

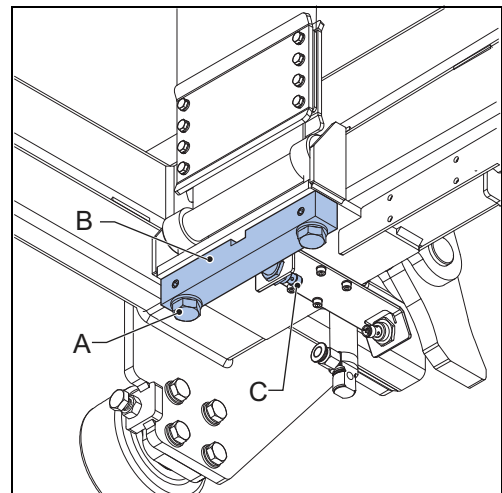

4.1.3 Mechanical locking device

- A Pneumatic cylinder
- B Extension spring
- C Locking pin
- D Sensor locking pin retracted

The locking device is actuated using compressed air. When compressed air is fed to the cylinders, they extend and rotate the locking pin to a position where the carrier is free to move. When the air pressure drops, the cylinder retracts and the extension spring rotates the locking pin back to the locked position.

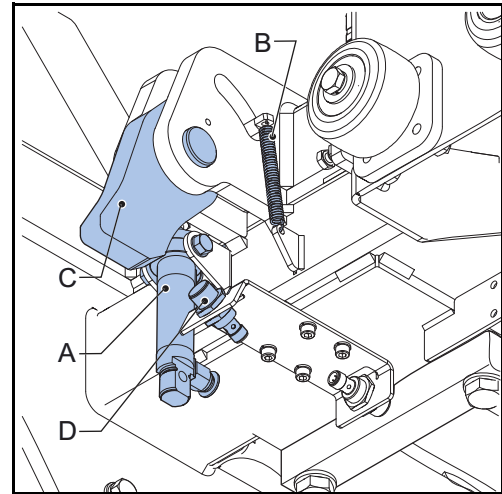

If personnel safety is at risk or in one of the situations below, the mechanical locking device needs to be activated:

- When an emergency stop is triggered, the safety pressure valve must let the air in the system escape.
- When a power failure occurs, the safety pressure valve allows the air to rapidly escape.
- When one or both sensors do not detect the locking pin, the pin is either extended or a malfunction had occurred. This must trigger an error. Do not move the carrier downwards.
 - When the pin is extended, the only movement that is allowed is a slow and manual operated upward movement of the carrier, with a maximum lift of 125 mm, to allow the locking pin to retract.
 - In all other cases, do not move the carrier at all.
- Before performing maintenance, always make sure that the locking pins are extended.
- When the locking pins are extended, the carrier can move a maximum of 125 mm downwards before the pin is properly locked in the slots in the column.



WARNING

Do not use the machine when the mechanical locking device does not function properly.

Refer to section 10.1 for the pneumatic diagram of the locking device.

4.2 Sensors

The following sensors are installed on the machine:

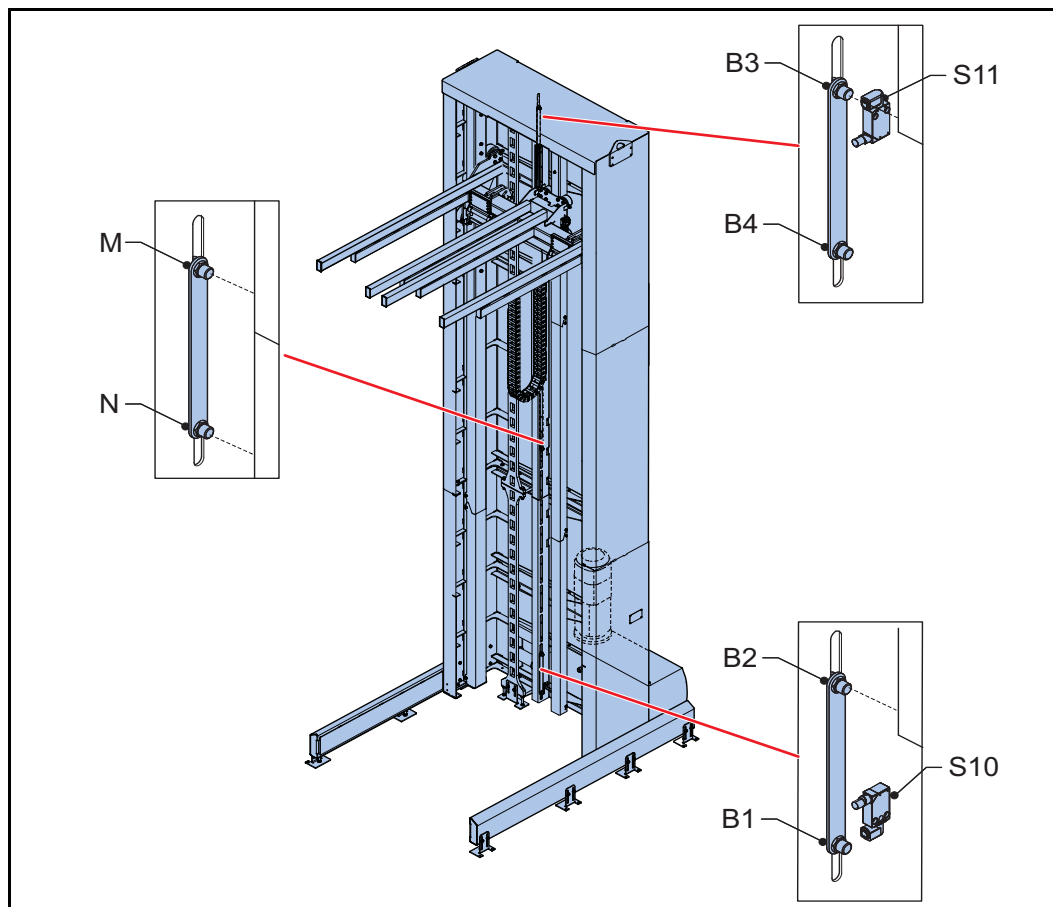

Sensor code	Sensor name
B1	Bottom level stop
B2	Bottom level low speed
B3	Top level stop
B4	Top level low speed
S10	Bottom limit switch
S11	Top limit switch

When the machine is configured to stop at more than two levels, two sensors (M#, N#) per extra level are installed in the column.

Sensor code	Sensor name
M#	Additional level # upward stop & downward low speed
N#	Additional level # downward stop & upward low speed

The movement of the carrier is restricted by the limit switches S10 and S11. When one of the limit switches is triggered, the machine must stop and the mechanical locking device must extend.

At each level two sensors are installed, by default B1 and B2 at bottom level and B3 and B4 at top level. When the carrier is moving and one of the sensors is activated, the carrier speed must be reduced to low speed. Once the second sensor is also activated, the carrier must stop.

When the carrier is positioned at a certain level both sensors are activated. When a product is placed on or removed from the carrier, the carrier can move due to the elongation of the belts. This can be detected when one of the sensors becomes inactive. To keep the carrier at the correct level, move the carrier in the direction of the inactive sensor.

4.2.1 Connection unit

- A Connection unit
- B Additional connection unit

The sensors in the column are wired through the cable tray in the column to the connection unit in the drive section.

When the machine is configured to stop at more than two levels, an additional connection unit is installed (B).

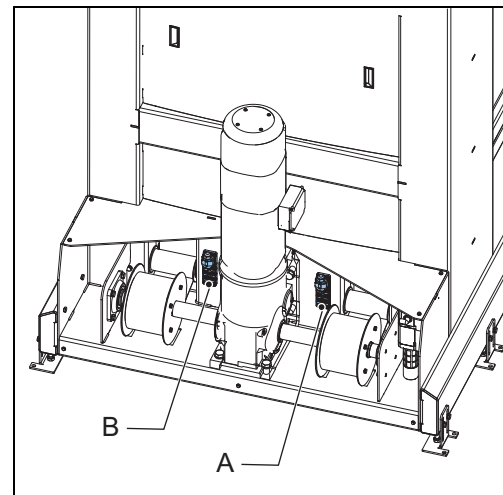

4.3 Motor

The motor drives the movement of the carrier. It is necessary to control this motor with a frequency inverter for controlled start/stop and optimum adjustment of the vertical speed. EMC directives must be observed and the device should be installed in accordance with the manufacturer specifications.



Note

When using a frequency inverter for hoisting applications, a braking resistor must be installed in order to dispense the energy that is generated by the drive motor when moving down. If there is no braking resistor, the energy causes too high voltage inside the frequency inverter.

If a braking resistor has been connected, it might be necessary to change some parameters of the frequency inverter. Please consult your frequency inverter supplier for detailed instructions, because these changes depend on the inverter brand.

4.4 Control

The control of the machine should be done from a central control system. Standard software blocks for Siemens are available at Qimarox.

The conditions for the control have been laid down in the technical specifications. When these conditions are not met, the emergency stop circuit of the machine must be activated.

4.5 Machine in a system

The following example is a general overview of the intended use of the machine within a system. In this example the carrier of the machine is equipped with a conveyor. The product is transported from a feeding conveyor at the bottom level to a discharge conveyor to a single top level.

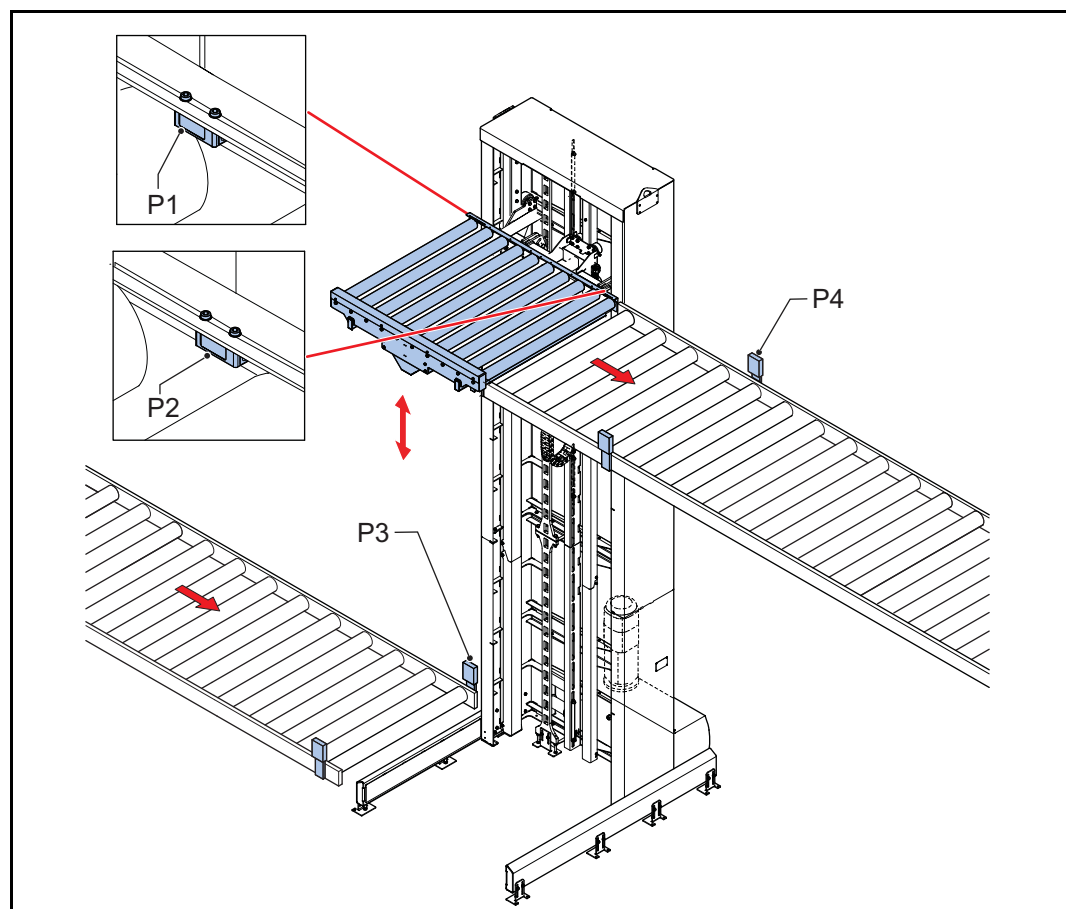

Infeed

The product is fed into the machine and monitored by sensor P3. This sensor is located on the end of the feeding conveyor. The product (A) will wait at sensor P3 until the carrier is in position. The carrier can move after a product has been transported into the machine and both sensors (P1 and P2) are not active, meaning the product is completely on the carrier.

Outfeed

After the carrier has moved to the outfeed level, the product can be transported onto the discharge conveyor. This is monitored by sensor P4, which must be positioned so the product is completely on the discharge conveyor before the sensor becomes active. Once the sensor is active, the carrier is free to move.

4.6 Specifications

The information below, the machine layout drawing, the specification sheet and the identification plate give the specifications for the transportation of products.

4.6.1 Product transport specifications

Data concerning product type, dimensions, stability and weights must always be verified with Qimarox.

When permitted weight and distance deviate from the specifications in the machine layout drawing, the machine must be adjusted to accommodate this. These type of adjustments may only be carried out by Qimarox or after written permission from Qimarox has been obtained.

If Qimarox does not supply the product conveyor, the weight of the applied conveyor needs to be checked by Qimarox to determine the correct drive on the vertical movement.

4.6.2 Environmental specifications

The surrounding area of the machine must comply to the following specifications:

Property	Description
General	Covered and normally clean for operation. There must be sufficient space around the machine for carrying out maintenance and other activities on the machine.
Relative air humidity	Maximum 80%.
Temperature	Between +5°C (41 F) and 40°C (104 F).
Floor	Even. The floor load is given in the machine layout drawing and specification sheet.
Required height	Refer to the machine layout drawing and specification sheet.
Compressed air	Between 5 bar and 7 bar in accordance with ISO 85731:2010 [7:4:4]

When the specifications for the surrounding area deviate from the table above, the machine must be adjusted to this. Such adjustments shall always be carried out by Qimarox or after permission from Qimarox.

4.6.3 Electrical specifications

See the type plate. Refer to section 2.1 and the electrical circuit diagrams.

Motor

The motor can be connected directly or through an operating switch in the main switch box. The machine must be controlled with a frequency inverter to ensure a smooth start and stop movement and to reduce speed.

The motor safety relays must meet EN-IEC 60204-1 specifications. The setting range depends on the motor specifications.

87Hz Drive

If you use a drive on 87 Hz, the drive can deliver up to 1.7 times its nominal power. This results in a smaller drive to do the heavy lifting. If you use this 87 Hz technique, you must consider the following:

- how to wire the drive
- the power of the frequency inverter
- the use of a braking resistor

Refer to the Qimarox specification sheet for drive parameters. The next figure shows an example of a drive that is used at a higher frequency.

DRIVE			
Geardmotor	K A87BDRE132MC4 - MAAB - 0° - 1		
Power	7,5	kW	
Torque	2140	Nm	
Speed	33	RPM	
Motor protection	TF	+ C- Protection cowl	
Insulation class	155(F)		
Frequency / Connection type	80	Hz	/ Δ (Delta)
Encoder	N/A		Standard by Qimarox N/A
Motor current	15,2	A	
Brake	BE11		
Brake holding current	0,52	A	
Certification	CE		
Regenerative power	7,6	kW	Requires braking resistor
Minimal power frequency inverter	8,4	kW	Due to 87Hz

- Frequency: indicates at which frequency the drive has to be controlled by the frequency inverter to reach the speed and capacity stated in the specification sheet.
- Connection type: indicates how the drive needs to be connected.
- Regenerative power: gives the maximum power a braking resistor needs to dissipate when the machine lowers a full load at the speed stated in the specification sheet.
- Minimal power frequency inverter: indicates the maximum power that the drive uses.

4.7 Application information

The machine layout drawing and specification sheet give the specific application information for the machine.

5 Installation

This chapter describes installation instructions. Refer to chapter 8 for exploded views of the machine.

5.1 Location

Refer to the machine layout drawing for detailed information about the location of the machine.

The minimum distance between moving parts of the machine and other equipment or structures must be 100 mm.

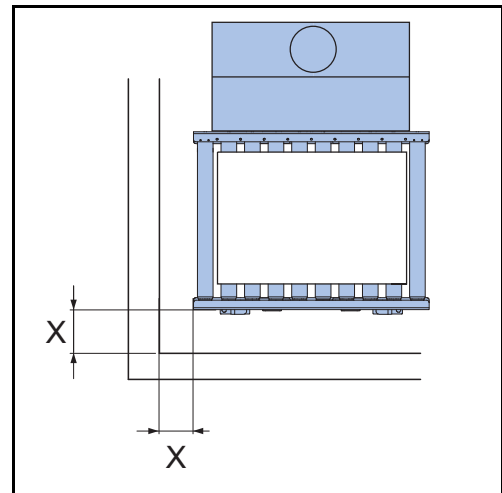

5.2 Delivery

The machine can be delivered pre-assembled or in parts.

- A pre-assembled machine will be delivered in a horizontal position.
- For a machine delivered in parts, the column section is delivered in an upright position in a crate.

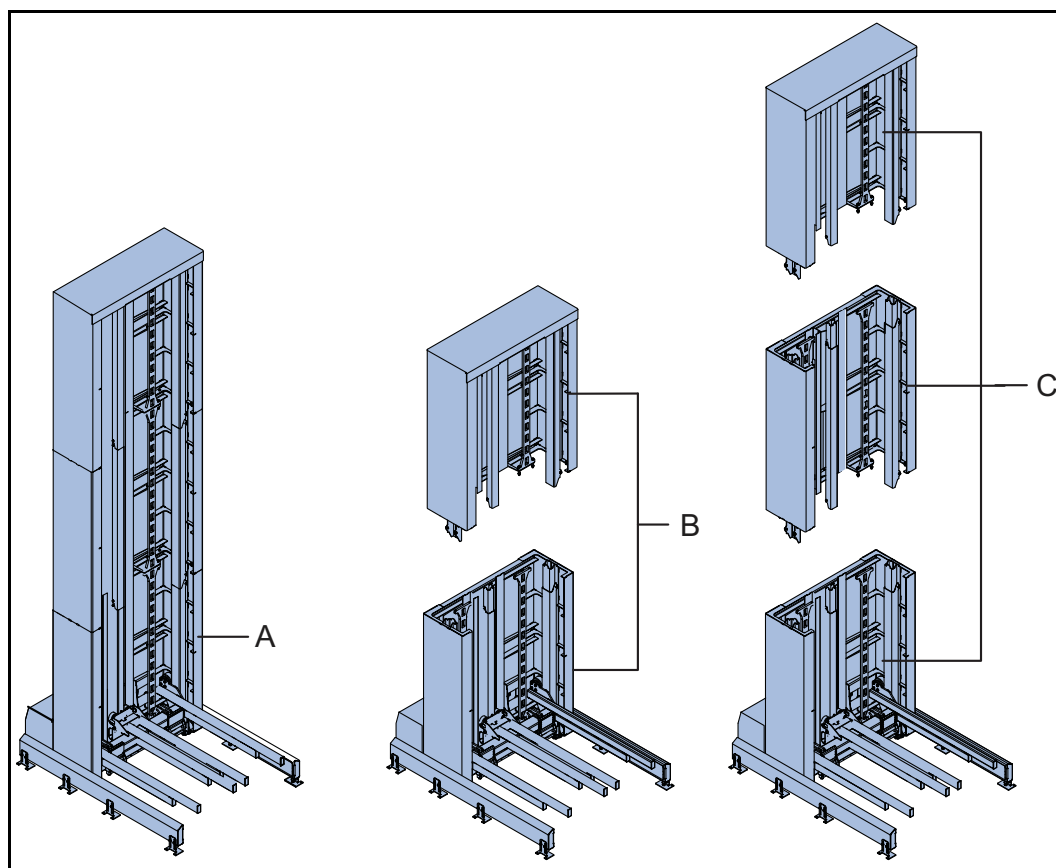

- A Machine pre-assembled
B Machine in two parts
C Machine in three or more parts

5.3 Transport

During transport, the machine must be placed in a horizontal position with the carrier facing upwards when fully assembled.

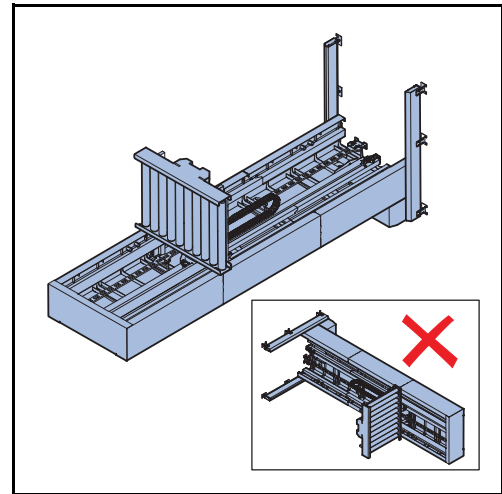

5.3.1 General preparation

1. Calculate the total weight before moving the machine.
 - The weight of the machine is given on the identification plate. Refer to section 2.1.
 - Add to this, the weights of any attachments to the machine, for example, product conveyors. The weights are given on the identification plates of the product conveyors.

5.3.2 Vertical transport

1. Check the type plate for the exact weight of the machine.
2. Use a suitable hoisting system that complies with local regulations.
3. Attach a suitable hoisting belt or hoisting chain (A) to the hoisting eyes of the machine.
4. If necessary, put the machine in the vertical position. Make sure that the machine does not tip over after it has been put in the vertical position.
5. Make sure that the bottom side of the machine (B) is not dragged along the ground during transport.

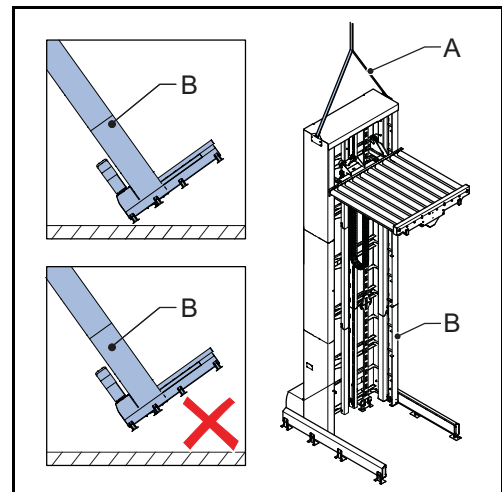

5.4 Unpacking

1. Check the packing list when unpacking the machine.
2. Immediately report damage or missing parts to Qimarox.

5.5 Preparations for a Qimarox installation (optional)

The preparations given below will need to be done before Qimarox can assemble the machine on site. All equipment listed below must be present before and during assembly.

1. Indicate the contact person to whom the mechanic of Qimarox must report when arriving or leaving before and after the installation. This only applies when Qimarox takes care of the installation.
2. Make sure that the mechanic of Qimarox is assisted by two qualified mechanics of the client. Refer to section 3.2.
3. Make sure that the location where the assembly takes place:
 - is accessible, has sufficient light, is at room temperature and is clean and dry.
 - has been laid out such, that the mechanics can work without interruptions and safely there.
 - is suitable for drilling and/or grinding, if necessary.
4. Provide hoisting equipment:
 - preferably a bridge crane, minimum carrying capacity 1.5 x the weight of the machine.
 - or a fork-lift truck combined with a hoist with a minimum capacity of 2 x the weight of the machine at a lifting height with a minimum height of the machine plus 2 meters.
5. Provide electric power (230 V AC) at a maximum of 5 metres from the place of assembly of the machine.
6. Provide the correct safety provisions:
 - Moveable scaffolding or a hydraulic hoist.
 - Personal protection equipment.

5.6 Installing the machine



WARNING

- The machine must only be set up by qualified personnel. Refer to section 3.2.
- Machines higher than 4 metres must be laterally supported in order to get sufficient stability in the column. Refer to the machine layout drawing.

5.6.1 Preparation

1. Make sure that a hoisting system above the machine is available. Refer to section 5.3.2.
2. Make sure that the surface is leveled and meets the requirements for carrying the total weight of the transport system. Refer to the machine layout drawing.
3. Keep the rear side of the machine accessible for service. Maintain a free space of approximately 800 mm.

5.6.2 Installing a pre-assembled machine

1. Position the machine using a hoisting system. Refer to section 5.3.2.
2. Check if the machine is completely level.
3. Anchor the machine (A).



Note

Use Fischer FBN II 12/100 bolts or equival. These bolts are not delivered by Qimarox. For the specifications of the bolts, see the information of the supplier.

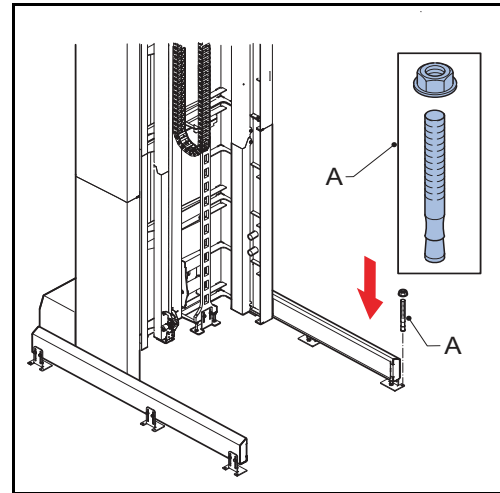

4. Make sure that the mechanical locking device works correctly and the locking pins are retracted from the locking. Refer to section 4.1.3.
5. Make sure that the cable carrier (B) is not damaged.
6. Make sure that the flat belts (C) run correctly over the pulleys.
7. Check if the carrier (D) can run freely.

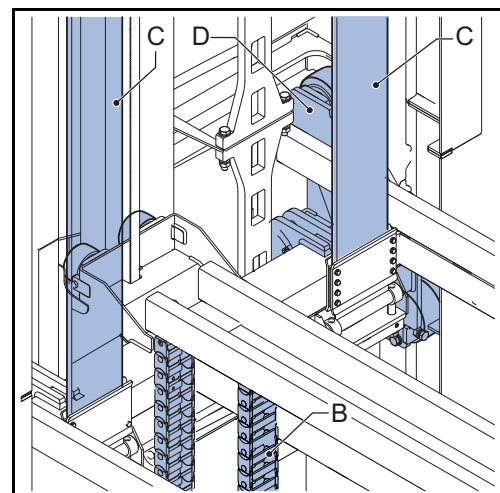

5.6.3 Installing a machine delivered in parts

1. Put the bottom section (A) with drive system and carrier on the correct location.

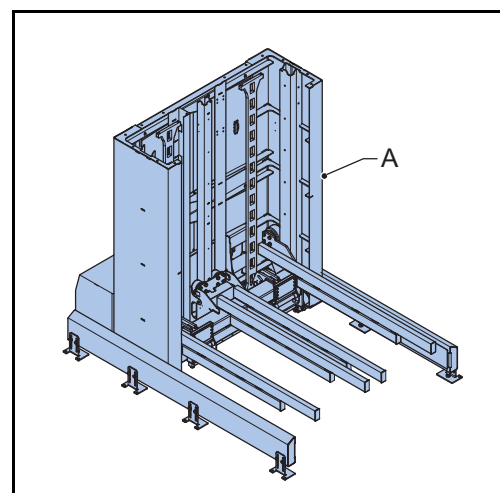

2. Determine which section comes next. Refer to the machine layout drawing.
3. Put the next section (B) on top of the previous section.
4. Connect both sections with bolts and tighten the bolts correctly.

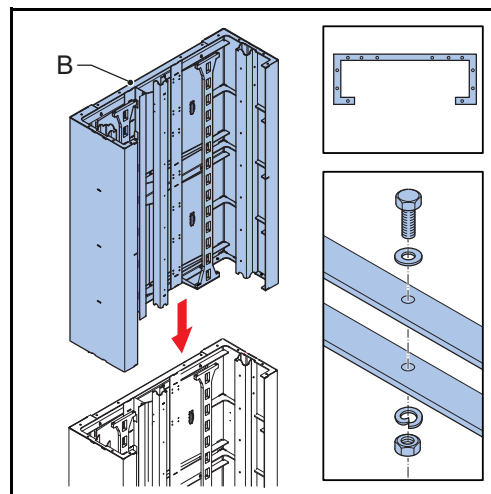

5. Connect the strips (C) for the mechanical locking device and tighten the bolts correctly.
6. Repeat steps 5 to 8 for all mid sections.

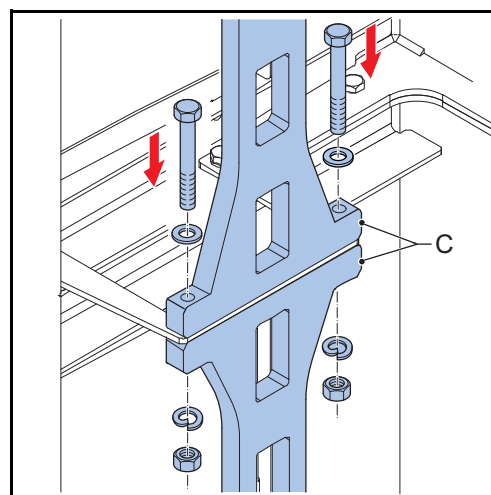

7. Put the top section (D) on top of the previous section.
8. Connect both sections with bolts and tighten the bolts correctly.

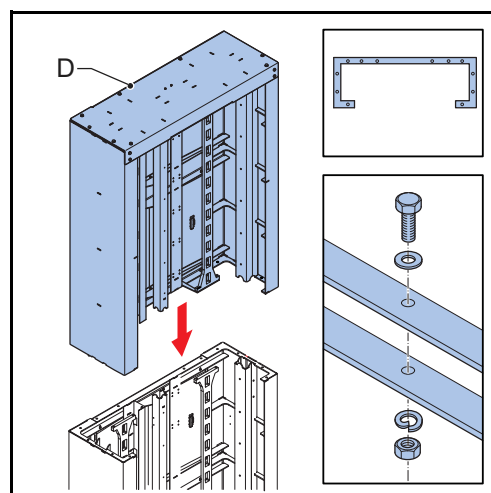

9. Connect the strips (E) for the mechanical locking device and tighten the bolts correctly.

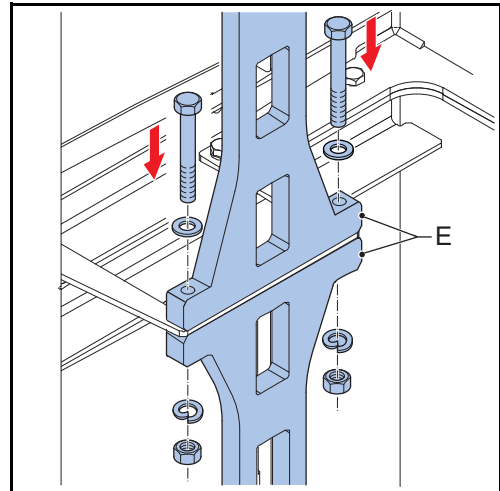

10. Install the running surfaces (F) and (G) in the bottom section.

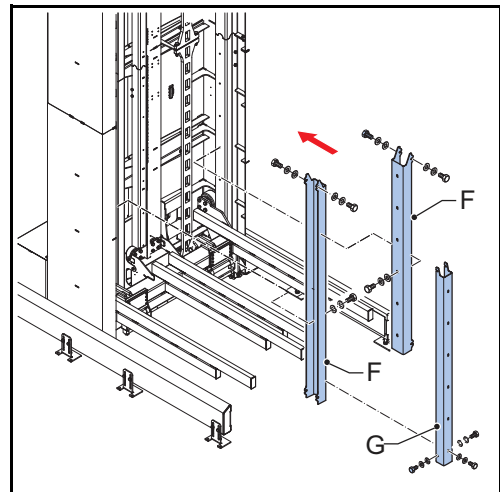

11. Install the running surfaces (H) and (I) in the mid sections.

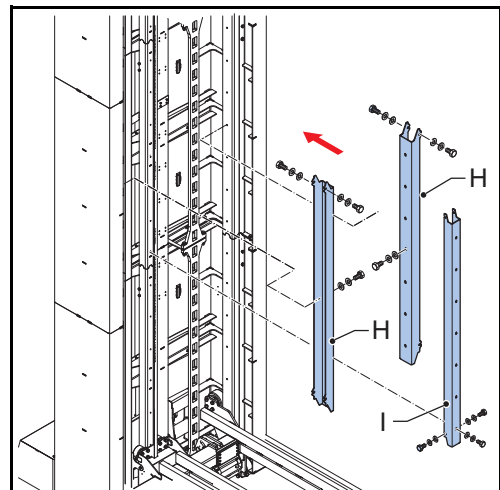

12. Install the running surfaces (J) and (K) in the top section.

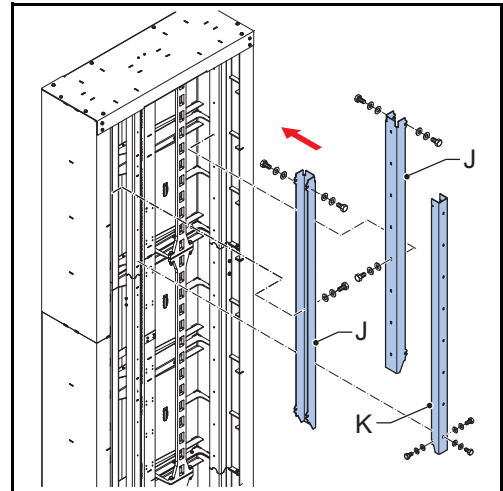

13. Unwind the flat belts (L).

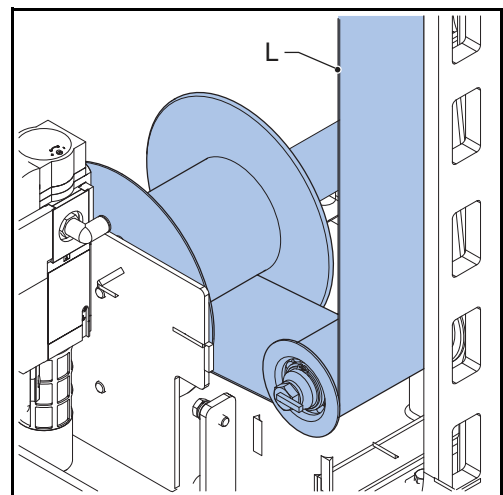

14. Guide the flat belts over the idler pulleys (M).

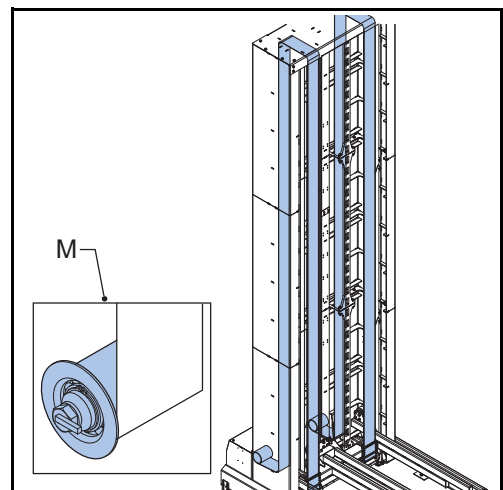

15. Attach the flat belts to the carrier with clamping plates (N).

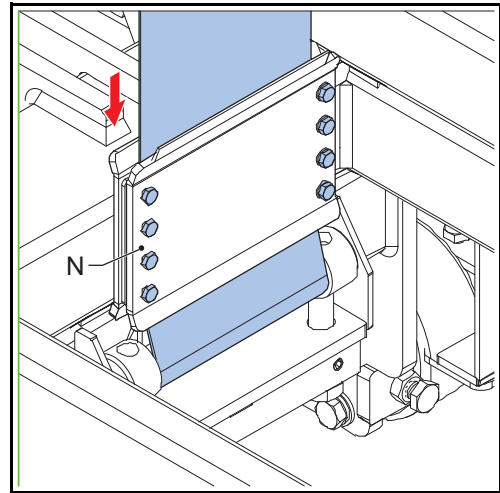

16. Install the cable carrier (P) with strip (O). Refer to the machine layout drawing for the correct position.

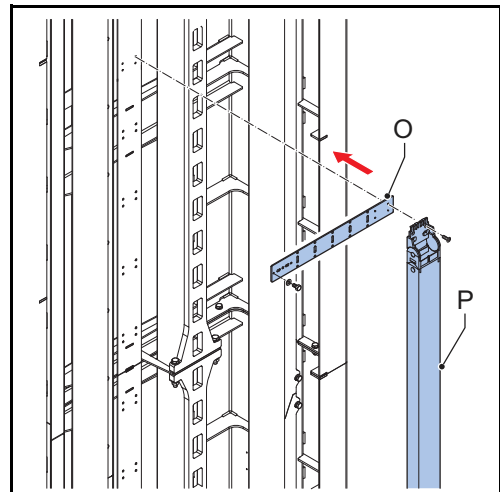

17. Connect the cable carrier to end piece (Q).
18. Connect the electrical parts in accordance with the electrical diagrams. Use the cable tray in the column to guide the cables to the drive section.

Refer to chapter 9 for more information about the electrical set-up.

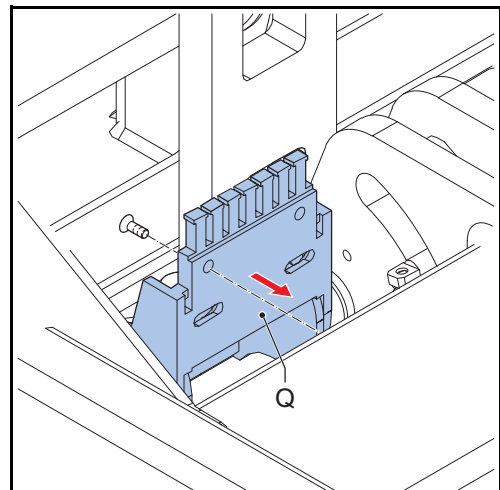

5.7 Installing the moveable conveyor



Note

If a moveable conveyor is included in the delivery, it is pre-installed on the carrier.

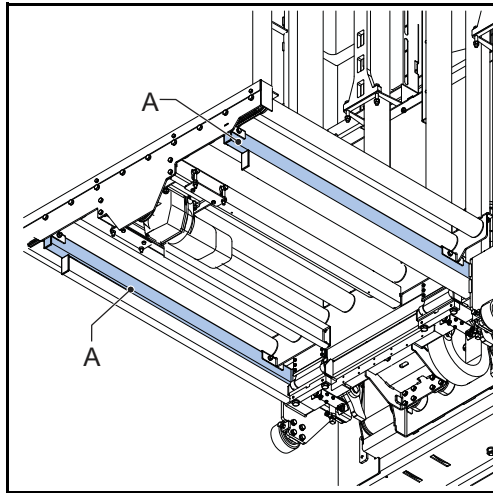

If a moveable conveyor is not included, you can install another conveyor. Only drill holes in parts (A) of the carrier for installation of the conveyor.

6 Maintenance



CAUTION

- The maintenance as described in this chapter is based on 2000 running hours per year. Adjust the maintenance frequency to the actual number of running hours per year.
- If required, Qimarox can carry out the maintenance activities.

6.1 Specific safety regulations

For the proper functioning of the machine the various machine parts must be regularly maintained. In this way defects and inaccuracies of the machine are prevented.



WARNING

- **Only a qualified maintenance engineer is allowed to carry out maintenance activities on the machine. Refer to section 3.2.**
- **Turn off the power supply to the machine with the main switch before starting any maintenance or repair activities. Secure the main switch with a padlock.**
- **Make sure that the locking pins of the mechanical locking device are extended.**
- **Do not use any corrosive and inflammable solvents or cleaning agents on the machine that contain TRI, PER, TETRA or FCHC. When you use chemical substances (cleaning agents), obey the instructions on the packaging.**
- **After having completed maintenance activities, always put all safety provisions that have been removed in place again.**
- **Make sure that the machine has always run empty before carrying out any activities. No products may be present in the machine.**
- **Take the appropriate measures for safely working at heights.**
- **Make sure that the mechanical locking device is deployed correctly.**

6.2 Preventive maintenance schedule

6.2.1 Daily maintenance

Item	Task	Action when required by the check
Guards	Check for visible damage.	Replace damaged guards.
	Check if the mounting materials are present and have been correctly placed.	Place the mounting materials or correct the way in which they have been fastened.
The entire machine	Check for visible dirt.	Clean the machine.

6.2.2 Weekly maintenance

Item	Task	Action when required by the check
Wheels of the carrier	Check for visible damage of the running surface and bearings.	Replace the wheels.
	Clean. Refer to section 6.3.	
	Check for running sounds.	Replace the wheels.
Flat belt	Check for wear and tear.	Replace the flat belt.
	Check for running sounds.	Lubricate the flange of the pulleys with silicone spray or teflon spray.
	Check the connection to the carrier.	Tighten the bolts and locking screw.
Cable carrier	Check for damaged links.	Replace the damaged links.
Cabling	Check the cables for visible damage.	Replace the cable(s).
Mechanical locking device	Retract and extend the locking pins.	Make sure that the locking pins lock the carrier when necessary.

6.2.3 Monthly maintenance

Item	Task	Action when required by the check
Motor reductor	Follow the instructions in the manual of the manufacturer of the motor reductor.	Follow the instructions in the manual of the manufacturer of the motor reductor.
Bearings of the wheels of the carrier	Check for play.	Replace the wheels.

Item	Task	Action when required by the check
Sensors	Check for visible damage.	Replace the sensor if necessary.
	Check for correct signals.	Adjust the sensor.
	Check for loose parts.	Fasten loose parts.
	Clean. Refer to section 6.3.	
Cabling	Check if all cables are fastened tightly.	Connect the cables again if necessary.
Winding shaft	Check the bearings for running sounds.	Replace the bearings.
	Check for visible damaged parts.	Replace the parts.
Idlers	Check the bearings for play and running sounds.	Replace the bearings.
	Check the fasteners.	Tighten the fasteners.

6.2.4 6-monthly maintenance

Item	Task	Action when required by the check
Motor reductor	Follow the instructions in the manual of the manufacturer of the motor reductor.	Follow the instructions in the manual of the manufacturer of the motor reductor.

6.2.5 2-yearly maintenance or after 10,000 running hours, whichever comes first

Item	Task	Action when required by the check
Motor reductor	Follow the instructions in the manual of the manufacturer of the motor reductor.	Follow the instructions in the manual of the manufacturer of the motor reductor.

6.3 Cleaning



WARNING

- Do not use any corrosive and inflammable solvents or cleaning agents on the machine that contain TRI, PER, TETRA or FCHC. Read the instructions on the packaging when use is made of chemical substances (cleaning agents).
- Electrical components should not make contact with water or other liquids.
- Do not clean the machine with compressed air or water under high pressure.
- Avoid parts made of rubber or plastic, such as cables and gaskets, from making contact with oil, solvents or other chemicals.

1. Make sure there are no products on the carrier.
2. Switch off the machine.
3. Secure the main power supply switch with a padlock.
4. Make sure that the mechanical locking device secures the position of the carrier.
5. Remove deposit and dirt by hand.
6. Report any damage to the technically responsible person or to Qimarox and make sure that any damage is remedied before restarting the machine.

7 Troubleshooting

7.1 Vertical conveyor

Problem	Possible cause	Solution
The motor does not run.	Electrical failure.	Remedy the electrical failure.
	The operation or main switch is on "OFF".	Set the operation/main switch to "ON".
	The door switch or emergency stop is active.	Release the emergency stop switch after having checked if the situation is safe.
The motor does not run and makes a humming sound.	Mechanical or electrical failure.	An authorised qualified person should disconnect the motor. Refer to section 3.2.
	No full power.	Check the power cable for a break or short circuit.
	Poor contact.	Check the terminal clamps.
	Defect in the motor.	Check the connection and the motor winding.
	Blown fuse.	Replace the fuse.
	Thermal safeguard triggered.	Investigate and remedy the cause of the heating.
	Motor protection triggered by short circuit or overload.	Investigate and remedy the cause. Then reset the motor protection.
	Defective power controller.	Investigate and remedy the cause. Replace the power controller.
The motor starts with difficulty.	Electrical faults such as "The motor does not run and makes a humming sound".	Check the starting current and the nominal current. Investigate and remedy the cause of the increased use of energy.
The motor is overheated.	Voltage and/or frequency deviates from the nominal value when switching on.	Connect the motor according to the data on the type plate.
	The supply voltage deviates more than 5% from the nominal motor voltage.	Find out why it deviates and try to remedy this.
	Insufficient motor cooling.	Check the ventilation openings in the motor housing for blockage. Check the fan for damage.

Problem	Possible cause	Solution
The motor gets overheated and runs at a low speed.	Loose contact or broken cable in the power circuit of the motor.	Check the power circuit for loose contacts or broken cables.
	Too high use of energy.	Check the weight of the product according to the data on the type plate. Check the motor on easily free movement.
	The settings of the frequency inverter are incorrect.	Adjust the settings.
The motor hums and does not run properly.	The motor runs with 2 phases, e.g. because of a faulty connection, broken cable or a defective winding.	Check the connections and the cable. Dismount the motor for repair.
The fuses blow and/or the motor protection is triggered.	The power has been connected incorrectly.	Connect the power in the correct way.
	Short circuit in the power.	Remedy the short circuit.
	Wrong fuse (too low value).	Adjust the fuse to the nominal motor current.
	Motor protection poorly set.	Adjust the motor protection to the nominal motor current.
	Short circuit in the winding or with respect to the earth.	Dismount the motor for repair.
The motor does not run. The motor protection is triggered immediately.	Incorrect setting of the motor protection.	Check and/or adjust the motor protection to the correct value.
	The mechanical drive (chains, belts, rollers or guides) are blocked.	Remove the blockage. Clean the machine. If possible, shorten the inspection/maintenance/cleaning intervals. Check the chains, drive belts, rollers, guides and the like for damage or incorrect adjustment.
Use of energy (motor current) too high and higher motor temperature.	The weight of the products is too much.	Make sure the specifications for use of the machine have been observed.
Use of energy (motor current) too high.	The drive belt does not run in line.	Align the drive belt.
Use of energy (motor current) too high and high temperature of the bearing housing (sometimes accompanied by sound).	Ball bearing, ball bush, return roller or the like is blocked.	Check the ball bearing, ball bush, return roller or the like and replace if necessary.

Problem	Possible cause	Solution
Abnormal sounds, unusual vibrations and swinging movements.	Drive system clogged by dirt.	Check the movement of the chain or drive belt and remove dirt or deposit. Shorten the cleaning interval.
	Guides or return wheels are dirty or damaged.	Check guides, chains and return wheels for damage or dirt. Replace or clean them as necessary.
Increased temperature of the bearings or bearing blocks. The idlers turn with difficulty.	Damaged bearings, bearing blocks or idlers.	Investigate and remedy the cause. Reset the motor protection.
	Loose bolt connections.	Investigate and remedy the cause. Reset the motor protection.
	Other machine parts run loose.	Investigate and remedy the cause. Reset the motor protection.

8 Exploded views

8.1 Frame parts

The following pages show exploded views of the frame parts and include part list and attachment materials information.

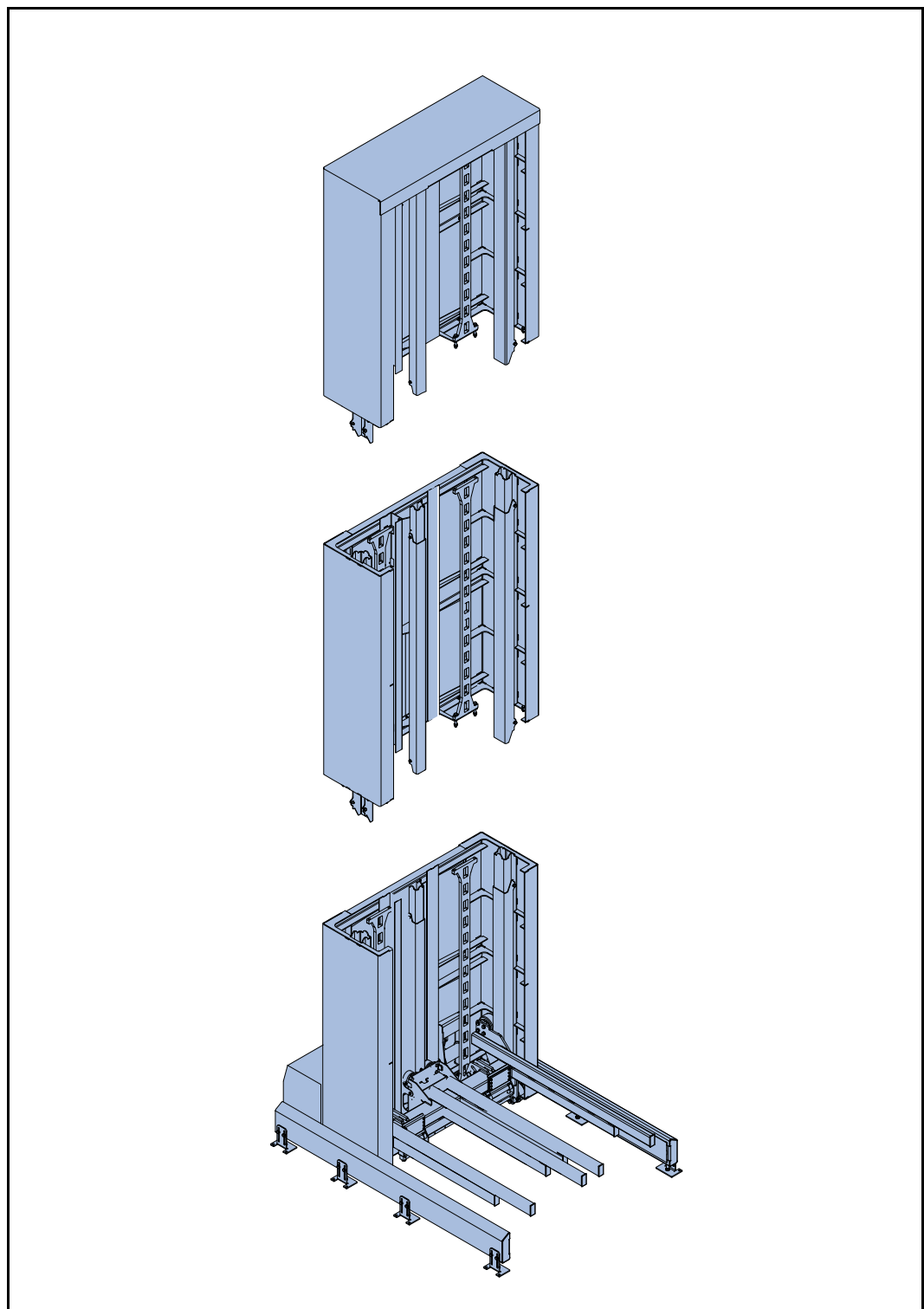

8.1.1 Top section exploded view

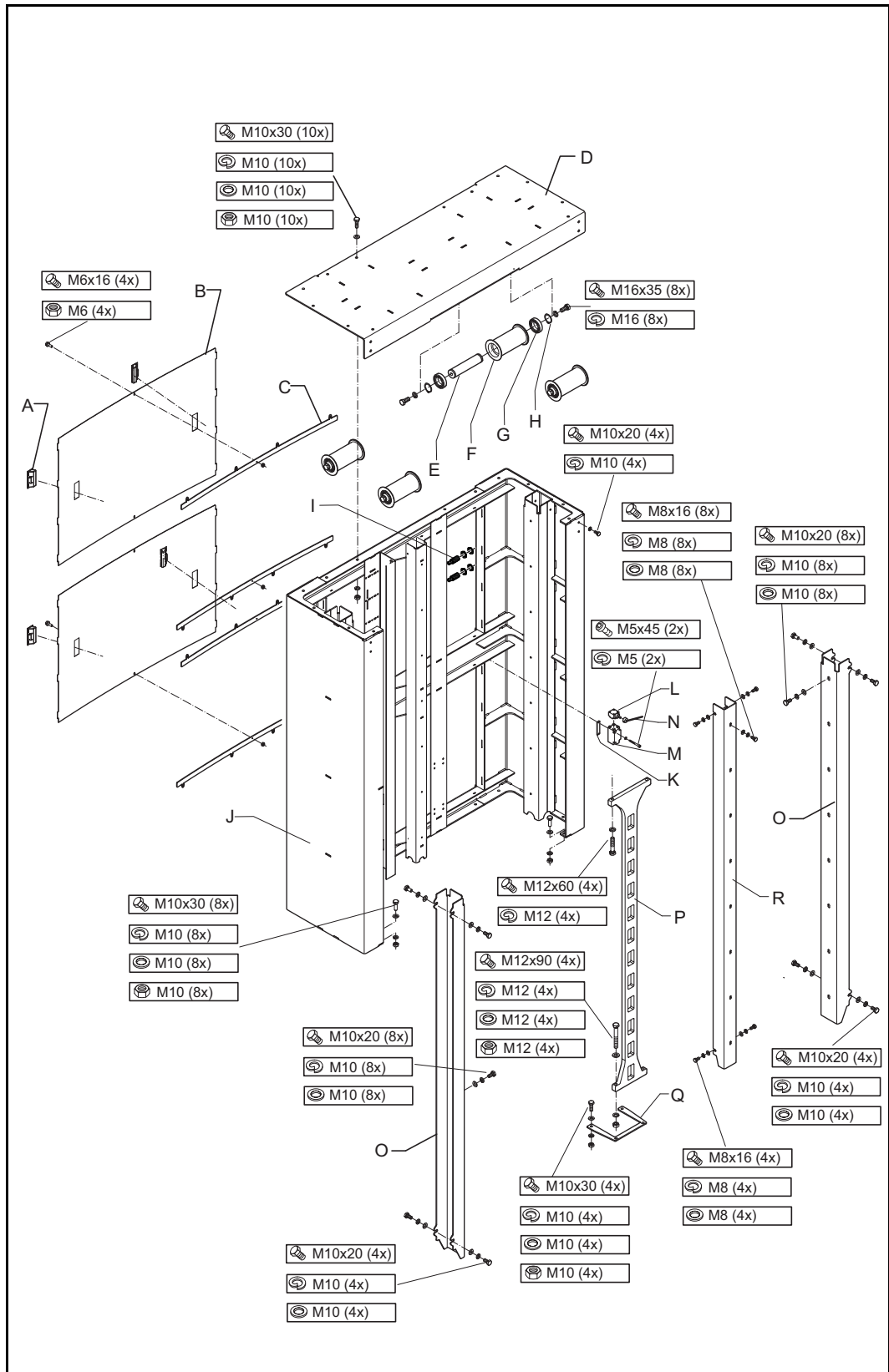

Top section parts list

Top section - parts list				
Pos	Quantity	Item number	Description (parts)	Notes
A	4	1000742	Pull handle	TS = 0.8 - 1.2 mm
B	2	AE000069302	Back shielding PRmk9	H = 573
	2	AE000069303	Back shielding PRmk9	H = 698
	2	AE000069304	Back shielding PRmk9	H = 823
C	4	AE0000695	Mounting strip shielding PRmk9	
D	1	AE0000664	End plate top section PRmk9	
E	1	AE0000583	Shaft idler belt PRmk9	
F	4	AE0000582	Idler belt PRmk9	
G	8	1003534	Ball bearing	6008 - 2RS
H	8	1002372	Circlip ring	A40 1.75
I	2	1000932	Sensor	IME 18-08BPSZC0K
J	1	AE0008223	Top section	H = 1475
	1	AE0008226	Top section	H = 1725
	1	AE0008220	Top section	H = 1975
K	1	AE0007201	Threaded plate	2 x M4
L	1	AE0005534	Limit switch head	
M	1	AE0005524	Limit switch body	
N	1	AE0005537	Limit switch lever	
O	2	AE000067901	Running surface top	H = 1475
	2	AE000067902	Running surface top	H = 1725
	2	AE000067903	Running surface top	H = 1975
P	2	AE000066801	Strip fall protection	H = 1475
	2	AE000066802	Strip fall protection	H = 1725
	2	AE000066803	Strip fall protection	H = 1975
Q	2	AE0000690	Plate fall protection	
R	2	AE000067301	Running surface top	H = 1475
	2	AE000067302	Running surface top	H = 1725
	2	AE000067303	Running surface top	H = 1975

8.1.2 Mid section exploded view

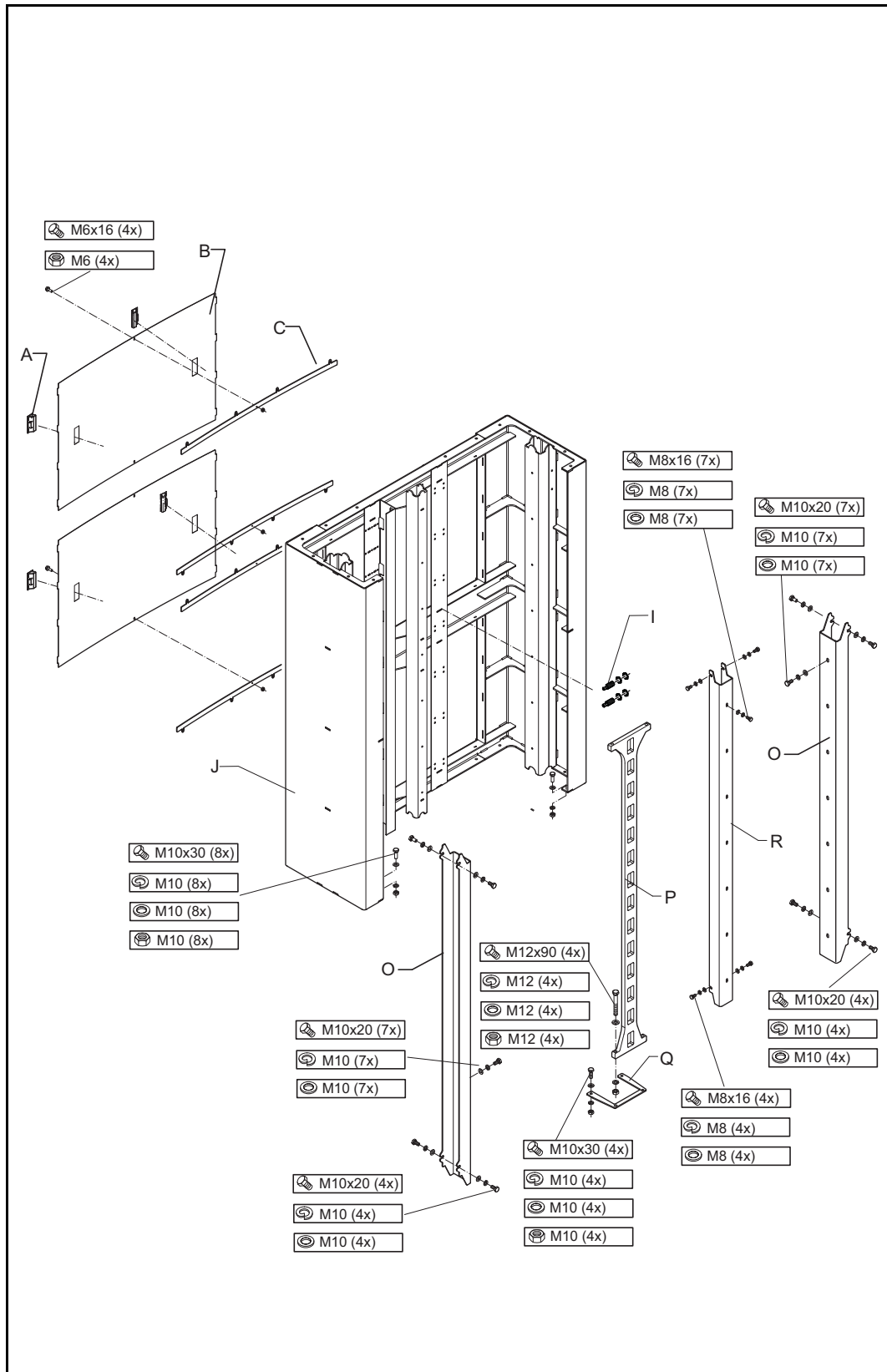

Mid section parts list

Mid section - parts list				
Pos	Quantity	Item number	Description (parts)	Notes
A	4	1000742	Pull handle	TS = 0.8 - 1.2 mm
B	2	AE000069301	Back shielding	H = 448
	2	AE000069303	Back shielding	H = 698
I	2	1000932	Sensor	IME 18-08BPSZC0K
J	1	AE0000520	Mid section	H = 1250
	1	AE0000529	Mid section	H = 1750
O	2	AE000068201	Running surface mid	H = 1250
	2	AE000068202	Running surface mid	H = 1750
P	2	AE000067001	Strip fall protection	H = 1250
	2	AE000067002	Strip fall protection	H = 1750
Q	2	AE0000690	Plate fall protection	
R	2	AE000067701	Running surface mid	H = 1250
	2	AE000067702	Running surface mid	H = 1750

8.1.3 Bottom section exploded view

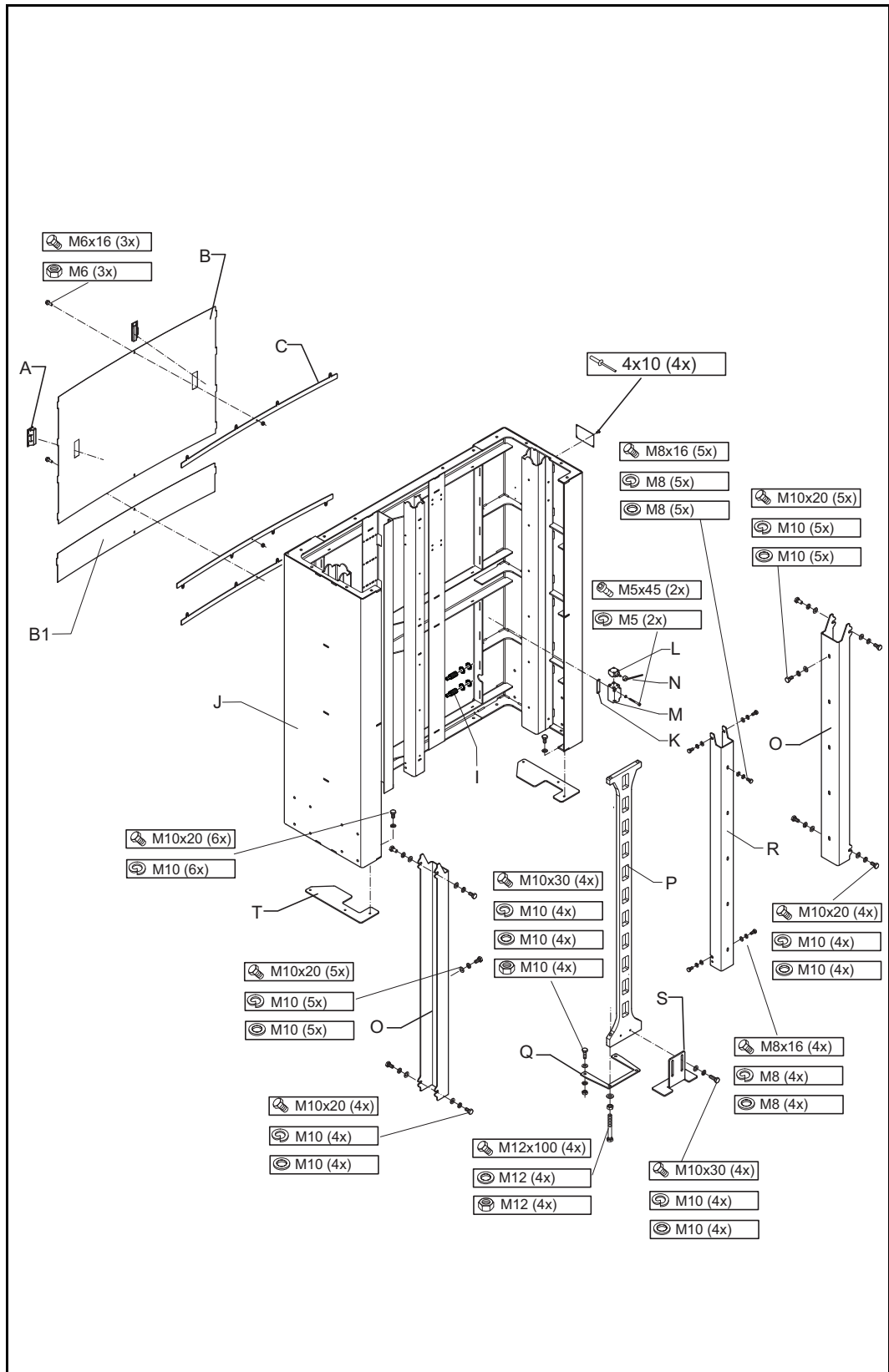

Bottom section parts list

Bottom section - parts list				
Pos	Quantity	Item number	Description (parts)	Notes
A	2	1000742	Pull handle	TS = 0.8 - 1.2 mm
B	1	AE000069302	Back shielding	H = 573
	1	AE000069303	Back shielding	H = 698
	1	AE000069304	Back shielding	H = 823
B1	1	AE000069308	Back shielding	H = 158
	1	AE000069306	Back shielding	H = 283
	1	AE000069307	Back shielding	H = 408
C	3	AE0000695	Mounting strip shielding	
I	2	1000932	Sensor	IME 18-08BPSZC0K
J	1	AE0000535	Bottom section	H = 1475
	1	AE0000541	Bottom section	H = 1725
	1	AE0000542	Bottom section	H = 1975
K	1	AE0000713	Threaded plate	2 x M5
L	1	1001532	Limit switch head	
M	1	1001531	Limit switch body	
N	1	1001533	Limit switch lever	
O	2	AE000068301	Running surface bottom	H = 1475
	2	AE000068302	Running surface bottom	H = 1725
	2	AE000068303	Running surface bottom	H = 1975
P	2	AE000067101	Strip fall protection	H = 1475
	2	AE000067102	Strip fall protection	H = 1725
	2	AE000067103	Strip fall protection	H = 1975
Q	2	AE0000690	Plate fall prot PRmk9	
R	1	AE000067801	Running surface bottom	H = 1475
	1	AE000067802	Running surface bottom	H = 1725
	1	AE000067803	Running surface bottom	H = 1975
S	2	AE0000711	Foot plate	
T	2	AE0000712	Endplate bottom section	

8.1.4 Carrier exploded view

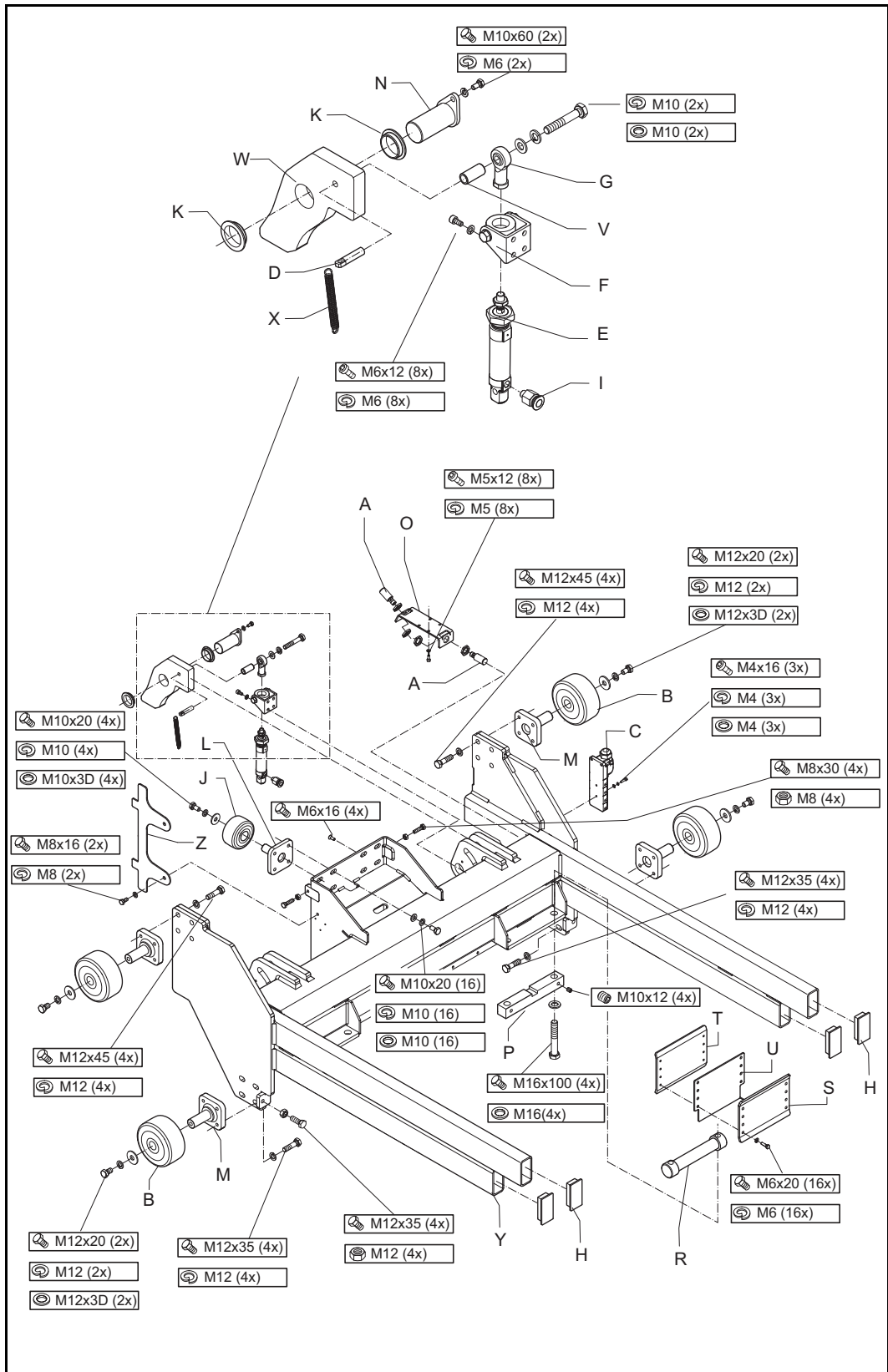

Carrier parts list

Carrier- parts list				
Pos	Quantity	Item number	Description (parts)	Notes
A	4	1000932	Sensor	IME18-08BPSZC0K
B	4	1002297	Wheel 125 x 55 bearing 25 x 60	
C	1	1003309	Exact 12-8 x M12 Junction box	
D	2	1003526	Bolt for extension spring	
E	2	1003527	Cylinder	ESNU-25-25-P-A
F	2	1003528	Pivot pin	SBN-20/25
G	2	1003529	Rod eye	M10 x 1.25
H	4	1003533	Tube cap rectangular	80 x 40
I	2	1003981	Push-in fitting	QS-1/8-10
J	4	1005551	Wheel 80 x 40 bearing 20 x 45	
K	4	1005552	Bearing Iglidur	G 30/34 x 9
L	4	AE0000548	Mounting bracket wheel	
M	4	AE0000549	Mounting bracket wheel	
N	2	AE0000552	Hinge fall protection	
O	2	AE0000722	Bracket detection	
P	2	AE0000736	Detection bar	
R	2	AE0000737	Linking shaft	
S	2	AE0000738	Clampingplate belt front	
T	2	AE0000739	Clampingplate belt back	
U	2	AE0000740	Clampingplate belt mid	
V	2	AE0000742	Spacer for rod eye	
W	2	AE0003729	Pin fall protection	
X	2	AE0000746	Spring	d=2.5 Dm=8.6 L0=68.5
Y	1	AE0000782	Carrier	for conveyor
	1	AE0000490	Carrier	for pallet
Z	1	AE0001248	Detection vane sensor	

8.1.5 Support exploded view

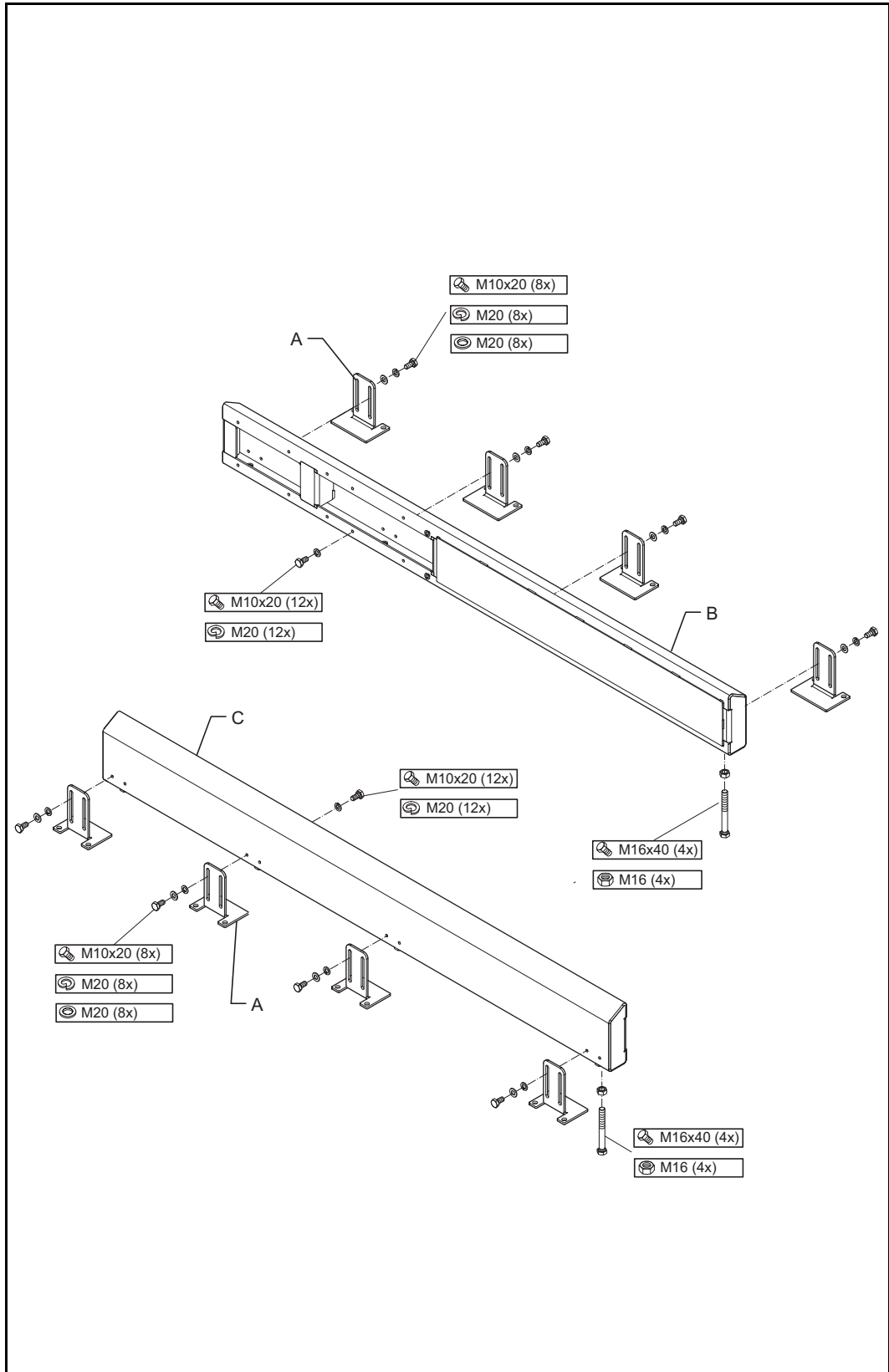

Support parts list

Support - parts list				
Pos	Quantity	Item number	Description (parts)	Notes
A	8	1000164	Adjustment foot	H = 156
B	1	AE0002182	Support right PRmk9	
C	1	AE0002178	Support left PRmk9	

8.1.6 Drive section exploded view

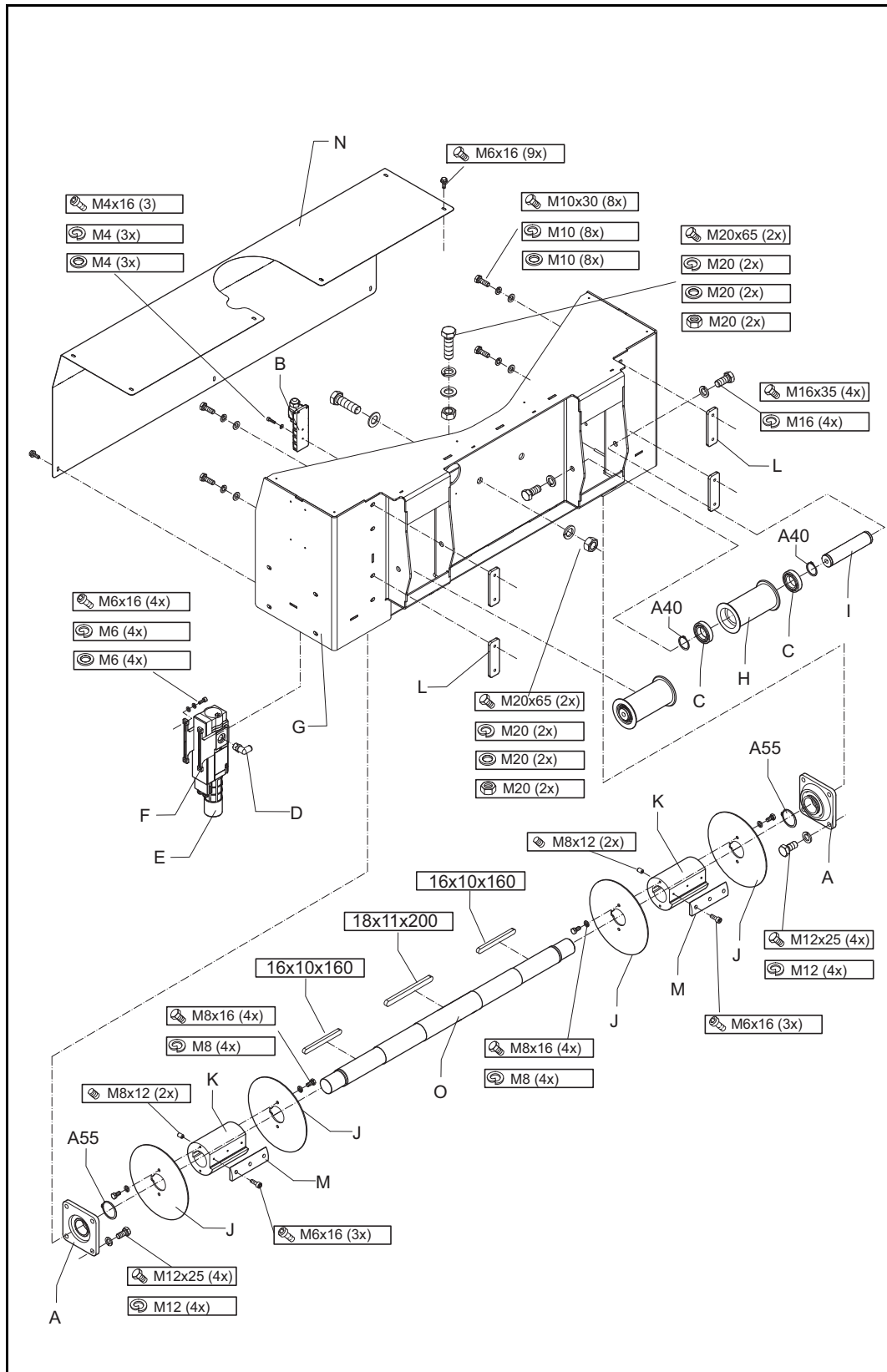

Drive section parts list

Drive section- parts list				
Pos	Quantity	Item number	Description (parts)	Notes
A	2	1002379	Housing unit	PCF50
B	1	1003309	Exact 12-8 x M12 Junction box	
C	4	1003534	Ball bearing	6008-2RS
D	2	1003982	Push-in fitting	QSL-1/2-10
E	1	1003983	Soft-start / quick exhaust valve	
F	1	1004038	Multi-pin plug socket	
G	1	AE0000558	Drive frame	
H	2	AE0000582	Idler belt	
I	2	AE0000583	Shaft idler belt	
J	4	AE0008161	Flange winding pulley	
K	2	AE0008146	Winding pulley large	
L	4	AE0000590	Threaded plate	2 x M10
M	2	AE0008159	Plate winding pulley	
N	1	AE0000612	Shield plate drive	
O	1	AE0001084	Shaft winding pulley	

8.1.7 Belts exploded view

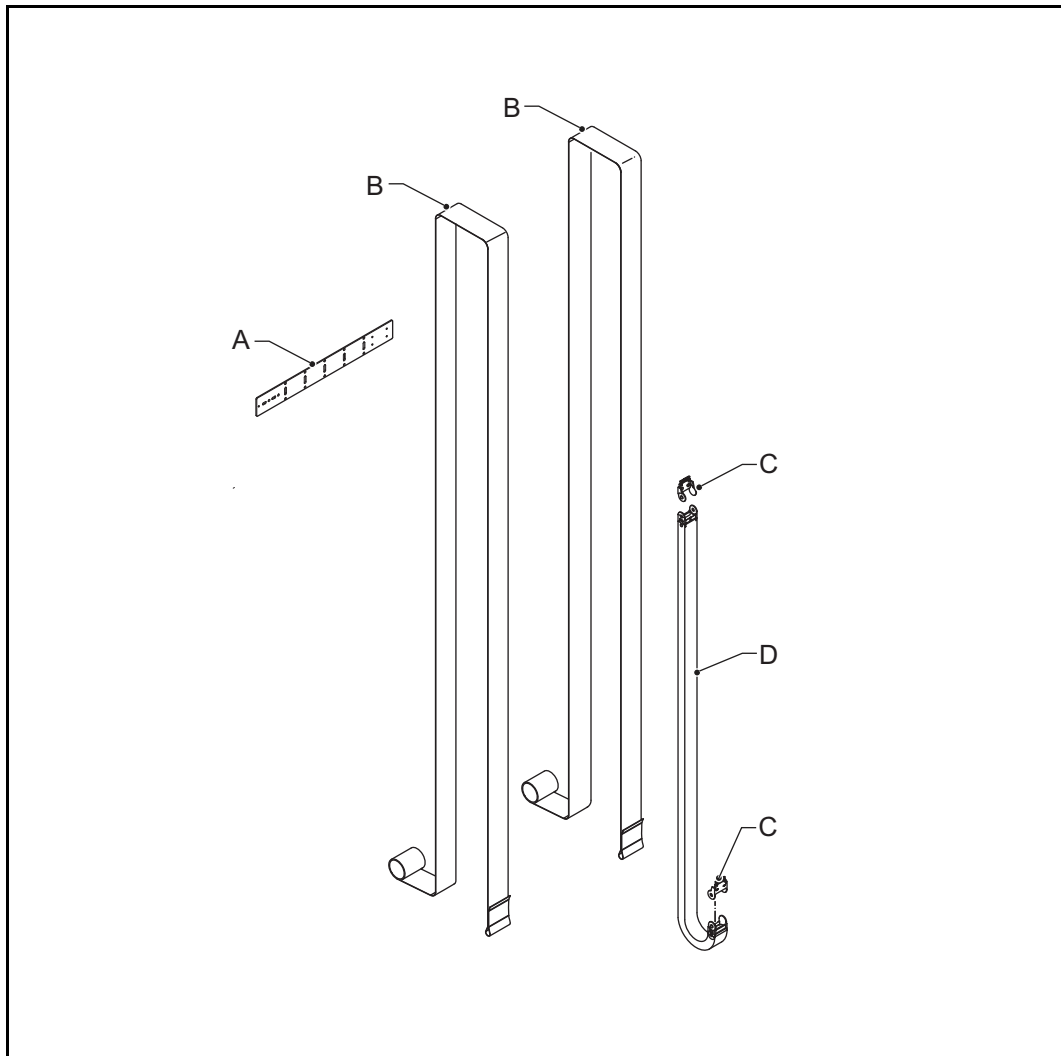

Belts parts list

Belts- parts list				
Pos	Quantity	Item number	Description (parts)	Notes
A	1	AE0001390	Cable crossing strip	
B	2	1004947	Belt	
C	1	1003532	Cable carrier connection set	
D	1	1003531	Cable carrier link	

9 Electrical circuit diagrams

9.1 Drives

9.1.1 Drive type: SEW 3PH

Connection main power:

<http://www.productliften.nl/media/text/240/247/680010306.pdf>

Connection TF:

<http://www.productliften.nl/media/text/240/247/681510306.pdf>

Connection BR:

<http://www.productliften.nl/media/text/240/247/69001006.pdf>

Other connection diagrams DR:

<http://www.productliften.nl/media/text/240/247/9pd0058us.pdf>

9.2 Installing 87Hz

9.2.1 Wiring the drive

In a traditional wiring diagram the drive is connected in a so-called star connection. To make sure that the drive does not lose any torque above 60Hz, it needs to be connected in a delta configuration. The next figure shows how this can be done. To reverse the configuration, interchange the supply leads L1 and L2.

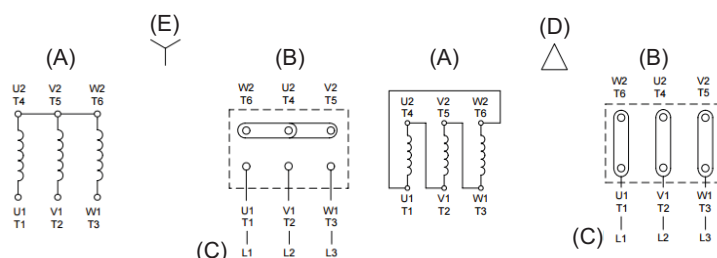

- A Motor winding
- B Motor terminal board
- C Supply leads
- D Delta-connected, low voltage
- E Star-connected, high voltage

9.2.2 Frequency inverter (not part of the standard Qimarox delivery)

Under normal circumstances the maximum power supplied by the inverter is equal to the nominal power of the drive. However, when using 87 Hz, the drive needs more power from the inverter than its nominal power. This is due to the increased frequency, which results in an increased output speed that leads (given that the torque remains the same) to increased power. The minimal power for the frequency inverter can be found in the Qimarox specification sheet at the technical data tab. The frequency at which the drive needs to run to reach the specified capacity is also indicated on the sheet.



WARNING

A braking resistor is necessary to make sure that the drive can dissipate any power when the load is lowered. The maximum amount of power that is generated by the machine can be found in the Qimarox specification sheet at the technical data tab. If the braking resistor is not installed properly, breakdowns will occur.

10 Pneumatic circuit diagrams

10.1 Mechanical locking device

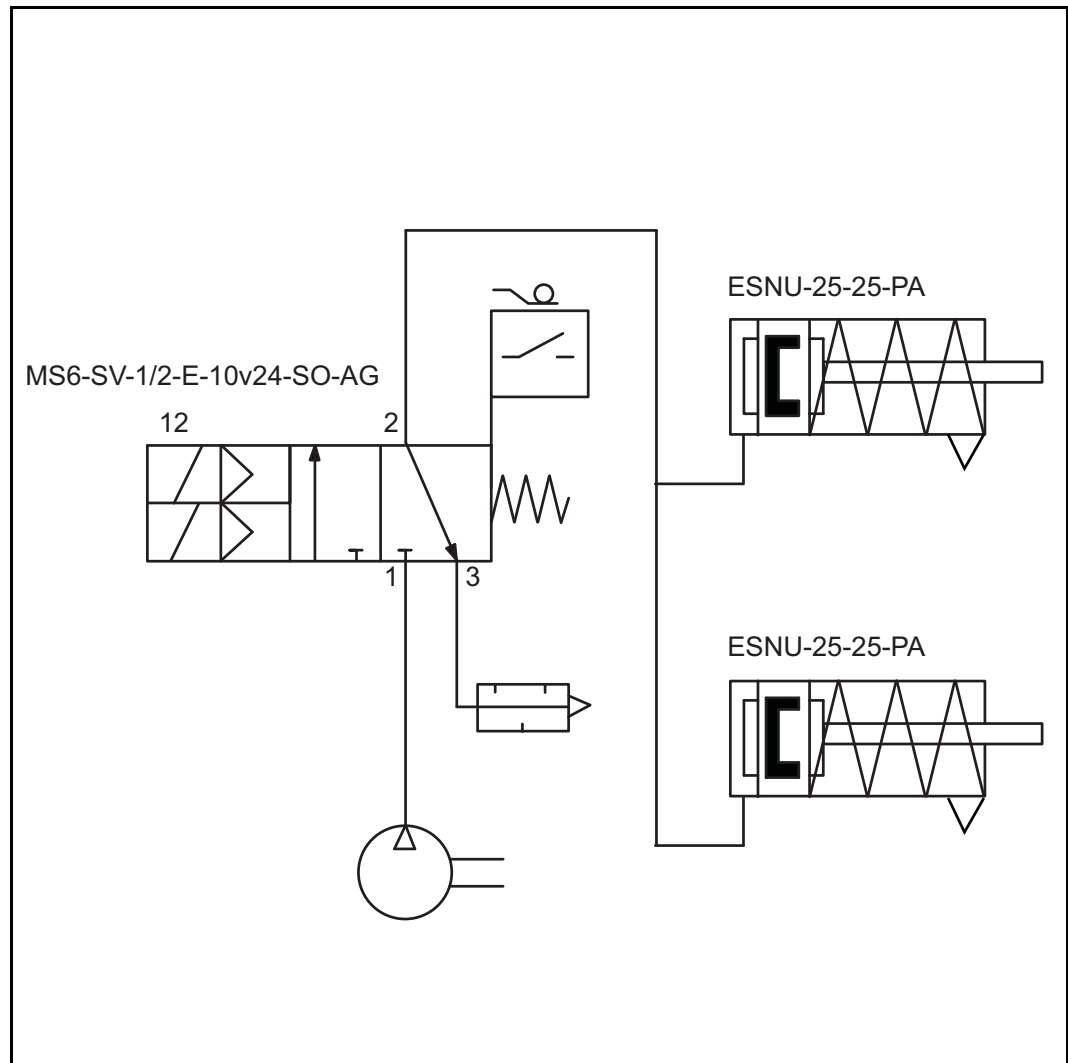

When power and compressed air is applied to the mechanical locking device, compressed air goes to the cylinders and the locking pin retracts. This will be applied until the emergency stop circuit is triggered or a power failure occurs. When this happens air will rapidly flow out of the cylinders and the locking pin will hook into the column, hence holding the carrier into its position.

11 Appendix

11.1 Product registration form

Fill in this form and send it to support@qimarox.com for correct product registration.

Machine type *	mk 1	mk 5	mk 9	mk 10
Order number Qimarox				
Serial number				
Integrated by				
Order number integrator				
Installation date				
Start production date				
Your reference (line / machine number)				
Contact details user				
Company name				
Address				
Zip code				
Town / city				
Country				
Phone number				
Fax number				
e-mail				
Website				
Technical contact user				
First name				
Last name				
Function				
e-mail				
Phone number				
spare parts ordered *	yes	no		
contact for service contract *	yes	no		

* Draw a circle around the choice.

REMARKS

THIS FORM IS USED TO INFORM THE USER OF QIMAROX PRODUCTS ABOUT MODIFICATIONS ON THE USED EQUIPMENT AND TO IMPROVE OUR SERVICE ON THE EQUIPMENT. THE CONTACT BETWEEN USER AND QIMAROX WILL BE THROUGH THE SUPPLIER / INTEGRATOR.



Nobelstraat 43
3846 CE Harderwijk
Tel: +31 341 436 700
Fax: +31 341 436 701
E-mail: info@qimarox.com
Internet: www.qimarox.com

Sensors on carrier PRmk9

Seesaw sensor

The carrier of the PRmk9 is suspended by two belts. Both belts are attached to a seesaw to distribute the load over the belts evenly. If a belt fails the seesaw is pulled out of balance, which removes the seesaw out of the sensing range of the sensor. If the carrier is obstructed while moving down, both belts loose tension. The extension spring pulls the seesaw out of balance, which removes the seesaw out of the sensing range of the sensor .

Both events must trigger an emergency stop.

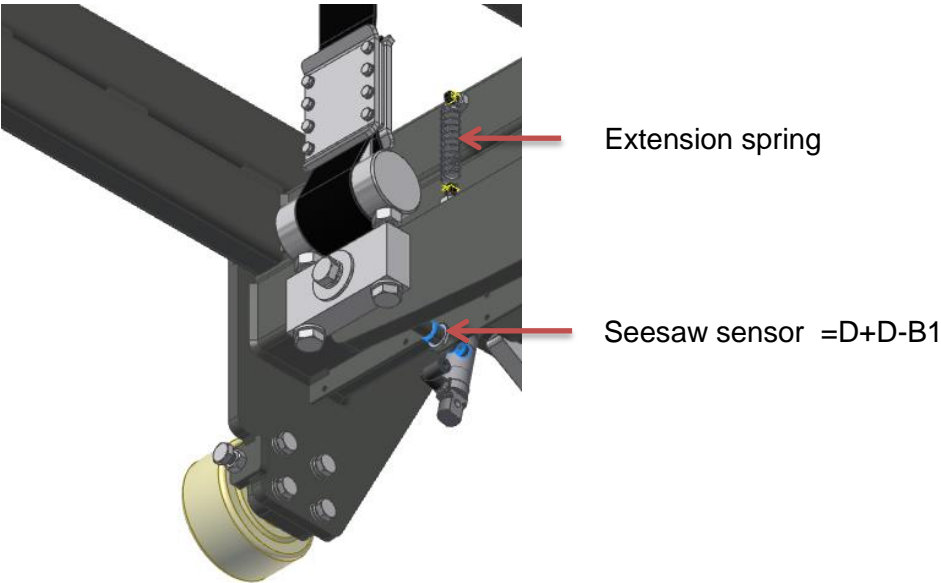

If the seesaw is not horizontal during normal use, it is out of the sensing range of the sensor. Use the adjustment bolts to level the seesaw.

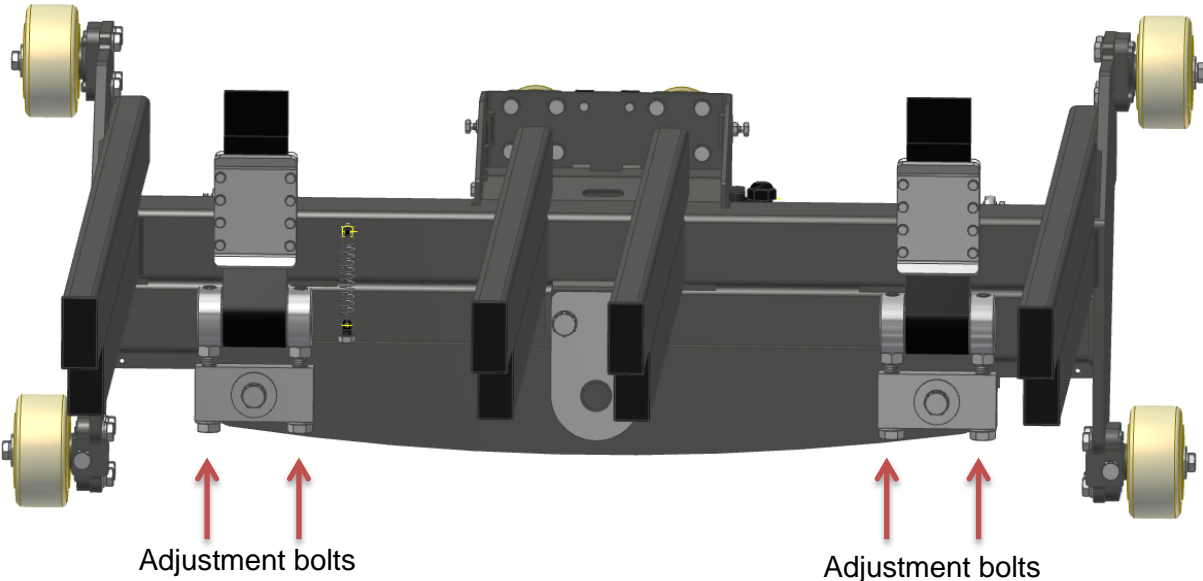

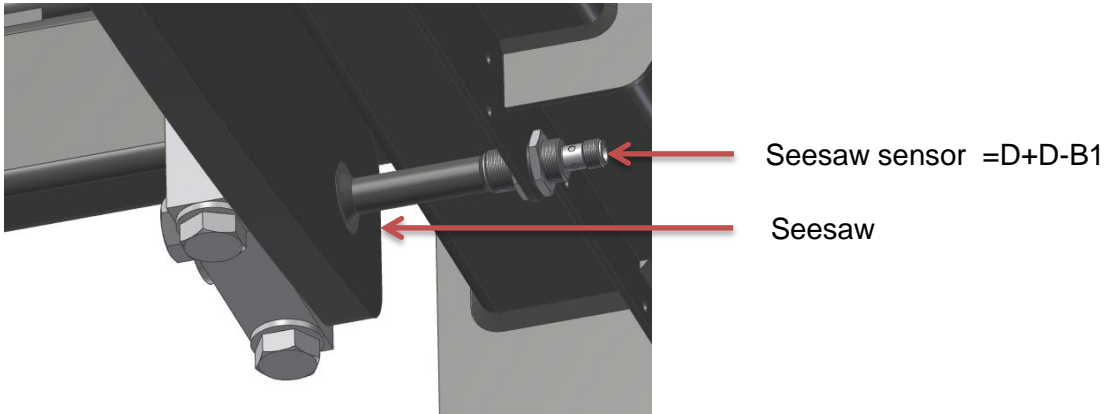

Tilting sensor

When the carrier is moving down while there is an object below it, this can cause the carrier to tilt. To prevent damage to the machine and surroundings, the machine is equipped with a sensor to detect this tilting.

The distance between the sensor and the centre guide must be 4 mm. When the centre guide is out of sensing range, the carrier is tilting and an emergency stop must be triggered.

