



Nobelstraat 43
3846 CE Harderwijk
The Netherlands

Phone: +31 341 - 436700
Fax: +31 341 - 436701
www.qimarox.com
info@qimarox.com

Document name: Electrical drawings PRmk5 (XL) v4.5
Mounting group: Prorunner mk5 (XL)
Type: Standard

Power supply: See specification sheet
Control voltage: 24VDC
According to: NEN-EN-IEC 60204-1: 2018

Version number: v4.5

Table of contents

Mounting group		Mounting location		Page	Page description
=A	Prorunner mk5 (XL)			1	Title page
				2	Table of contents
				10	Layout column without encoder
				11	Layout column with encoder
				12	Layout infeed conveyor
				13	Layout outfeed conveyor
				20	Overview passive plug-in terminal column without encoder
				21	Overview passive plug-in terminal column with encoder
				2000	Parts list
				2001	Parts list
+01	Detection column			500	Field components
+01	Detection column			501	Field components
+02	Gearmotor column			150	Gearmotor, 3 fase
+03	Detection infeed conveyor			501	Field components
+04	Drive infeed conveyor			100	Rollerdrive, 24VDC
+04	Drive infeed conveyor			150	Gearmotor, 3 fase
+05	Detection outfeed conveyor			501	Field components
+06	Drive outfeed conveyor			100	Rollerdrive, 24VDC
+06	Drive outfeed conveyor			150	Gearmotor, 3 fase

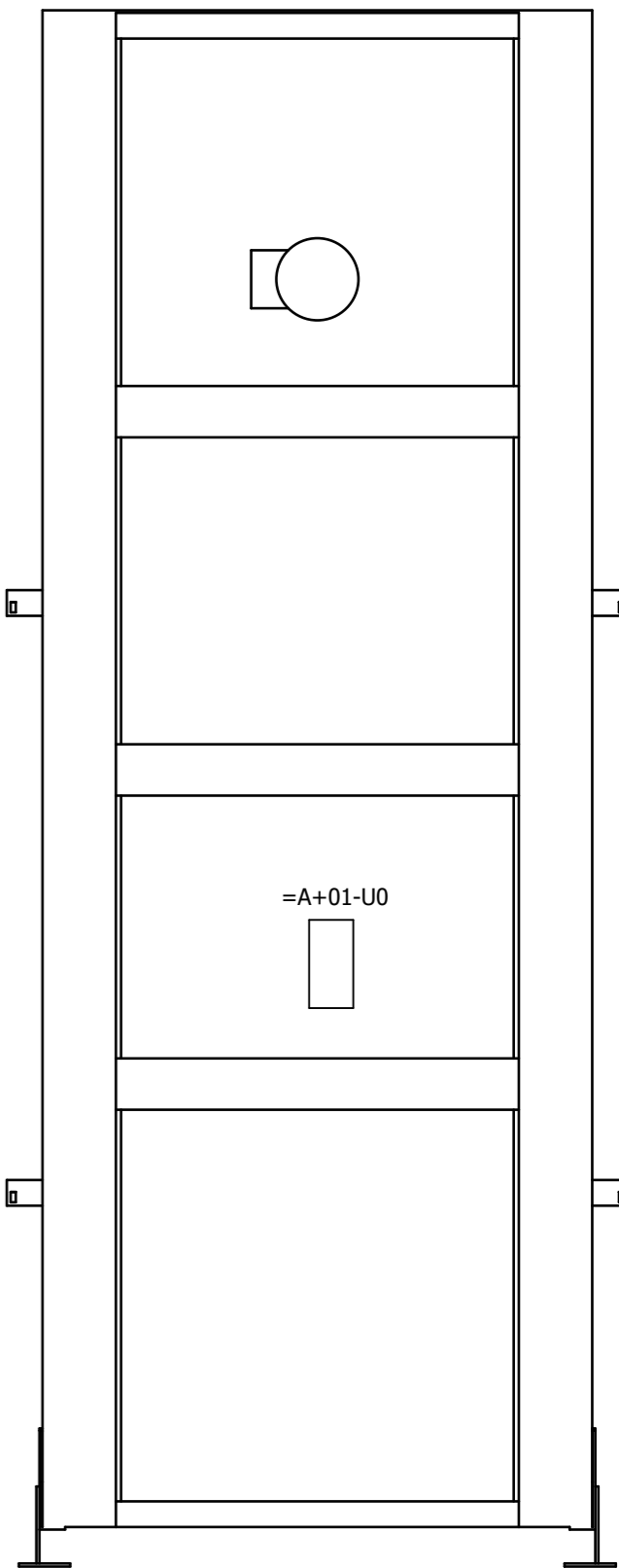
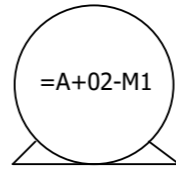
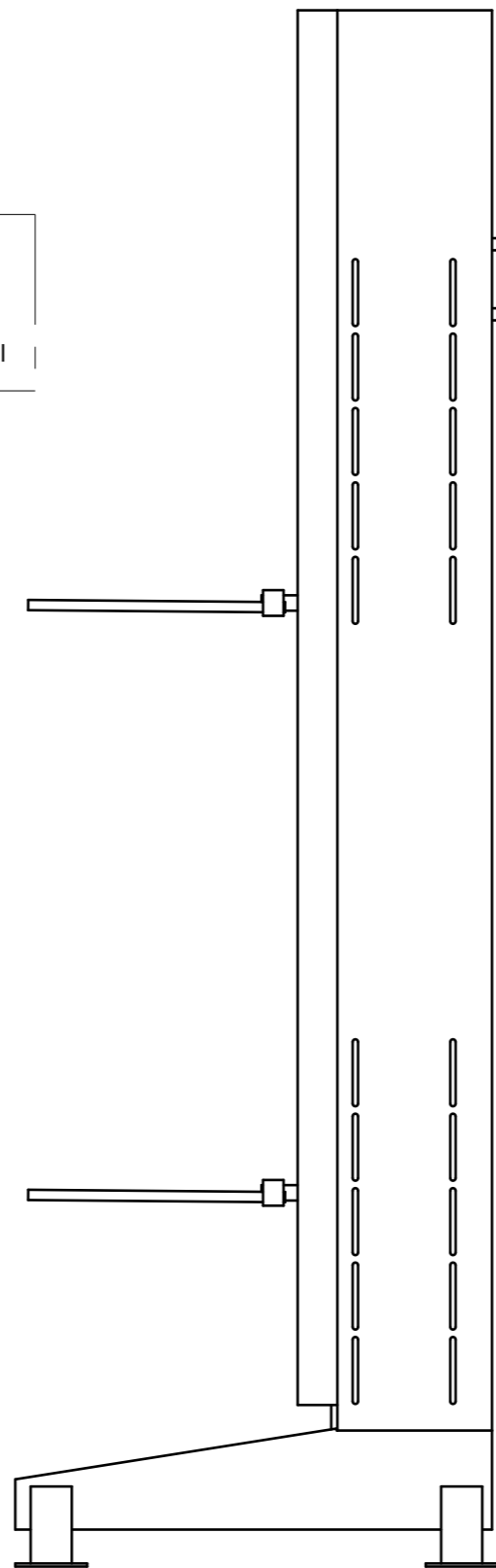
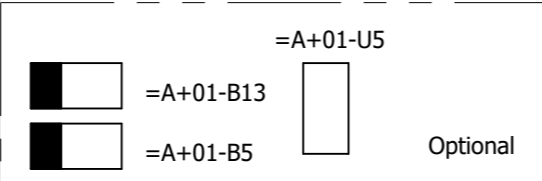
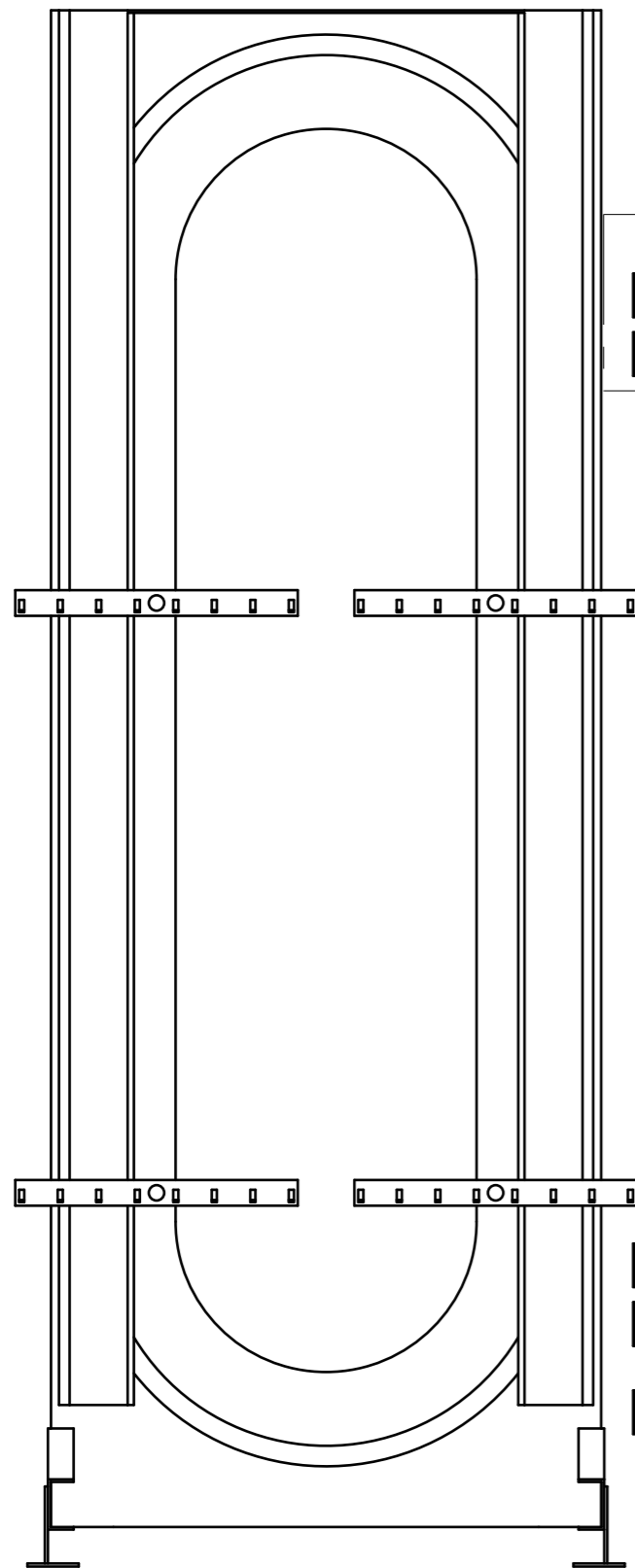

Legend:



=A+02-M1	Gearmotor Prorunner mk5	
=A+01-B6	Rotation detection	
=A+01-B3	Infeed security	
=A+01-B4	Outfeed security	
=A+01-B5	Infeed security reverse	Optional
=A+01-B13	Outfeed security reverse	
=A+01-U0	Passive plug-in terminal Prorunner mk5	
=A+01-U5	T-coupler column reverse	Optional

Application without encoder

For technical specifications of gearmotor, applied options, machine configuration and other data see specification sheet.

Image may differ from reality.

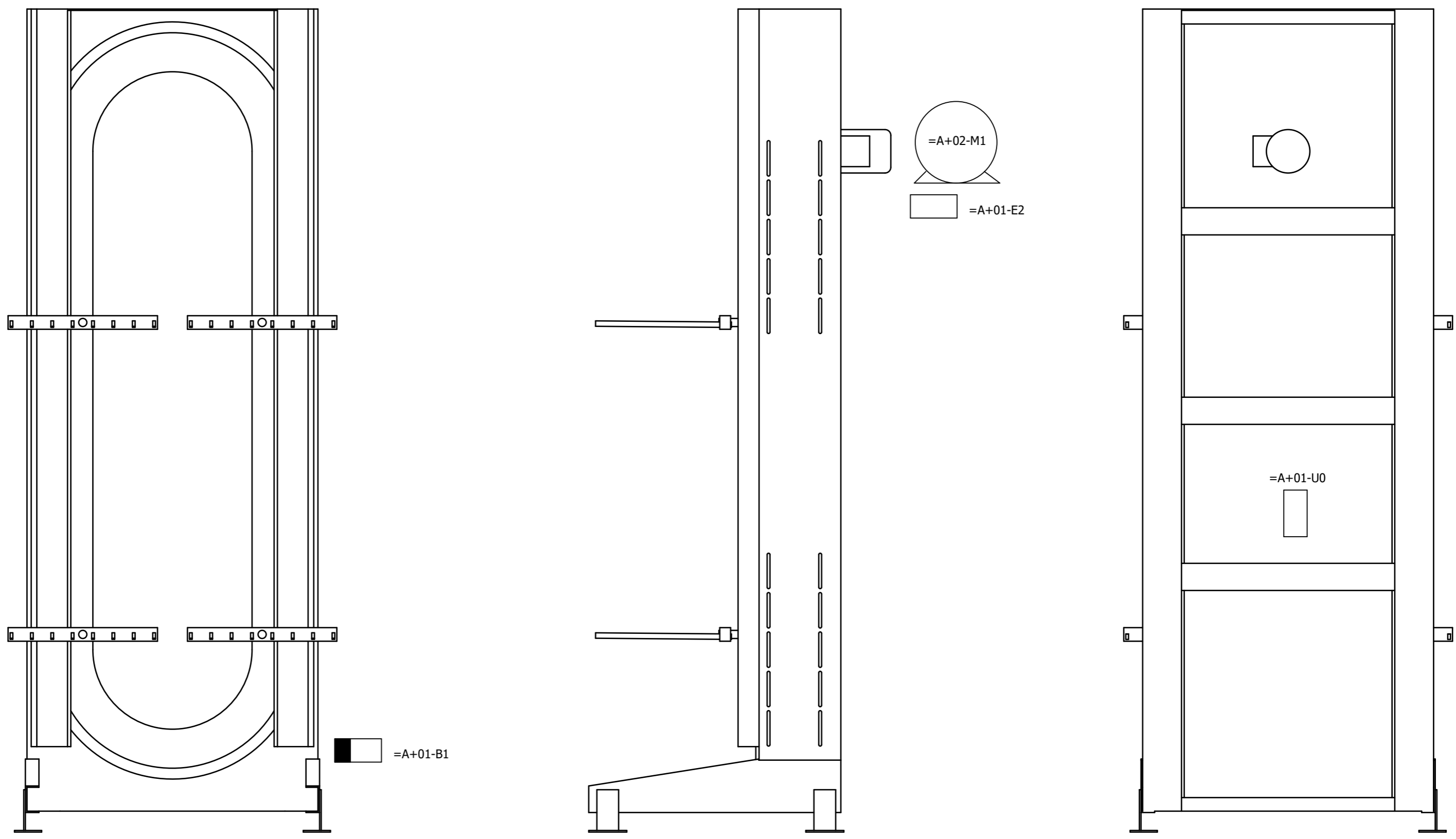

Legend:

- =A+02-M1 Gearmotor Prorunner mk5
- =A+01-E2 Encoder
- =A+01-B1 Reference position
- =A+01-U0 Passive plug-in terminal Prorunner mk5

Application with encoder

For technical specifications of gearmotor, applied options, machine configuration and other data see specification sheet.

Image may differ from reality.

Optional

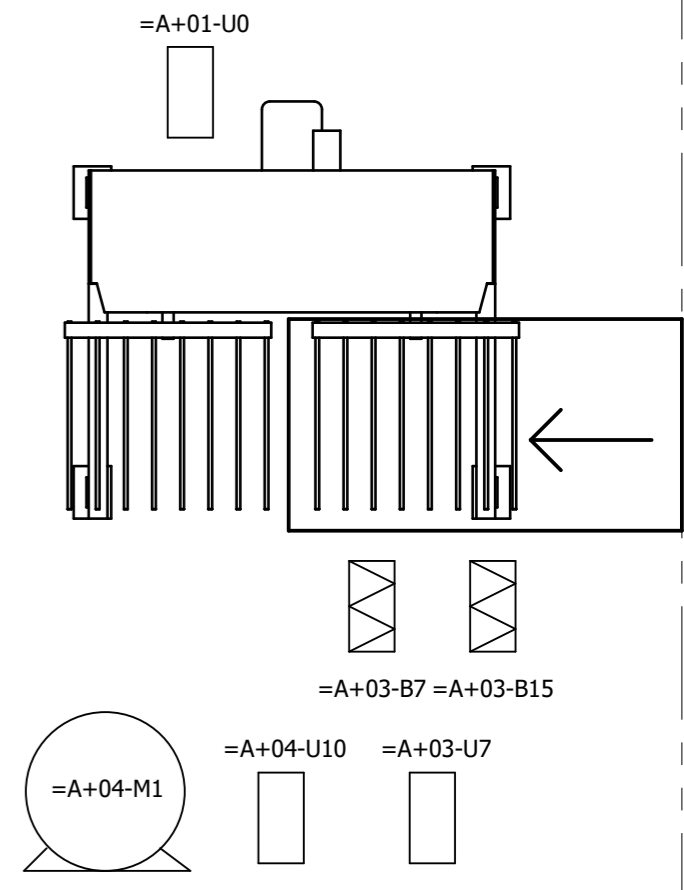
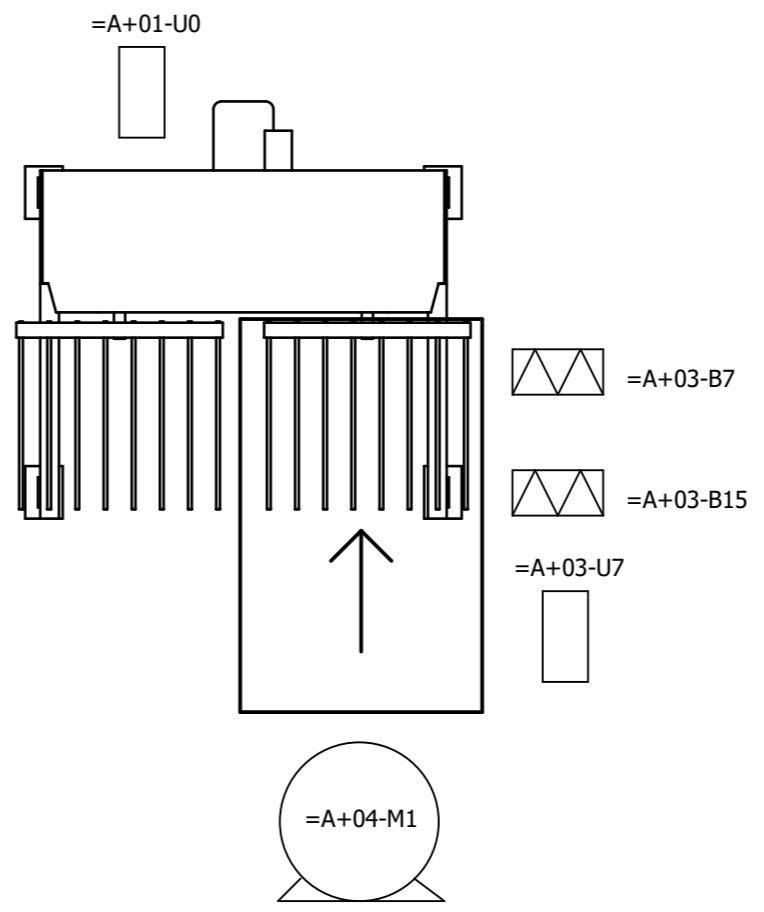
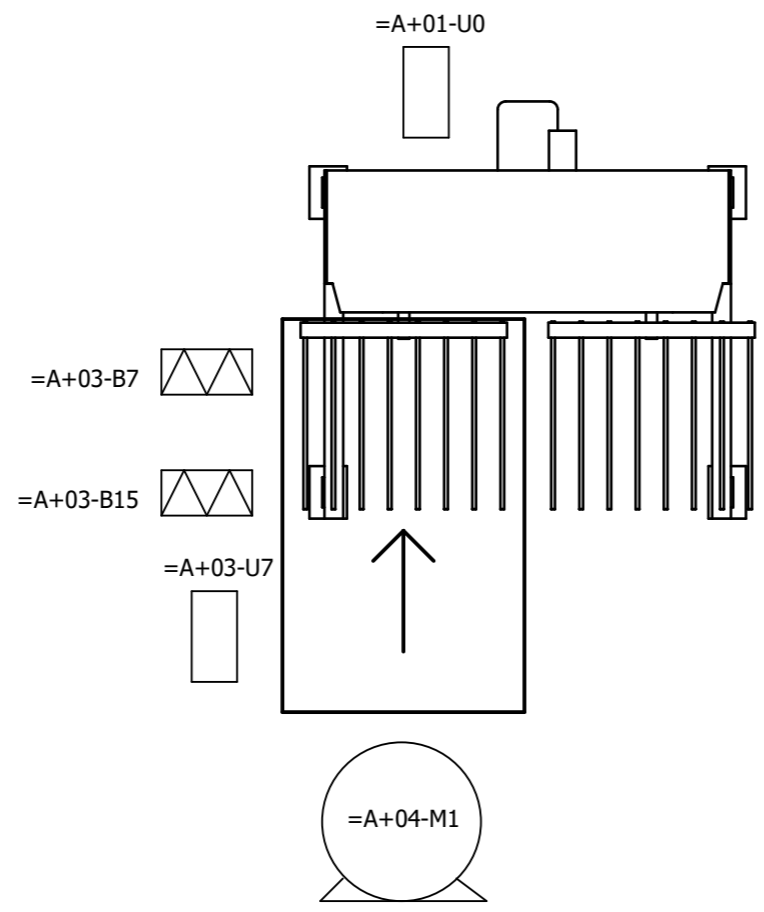
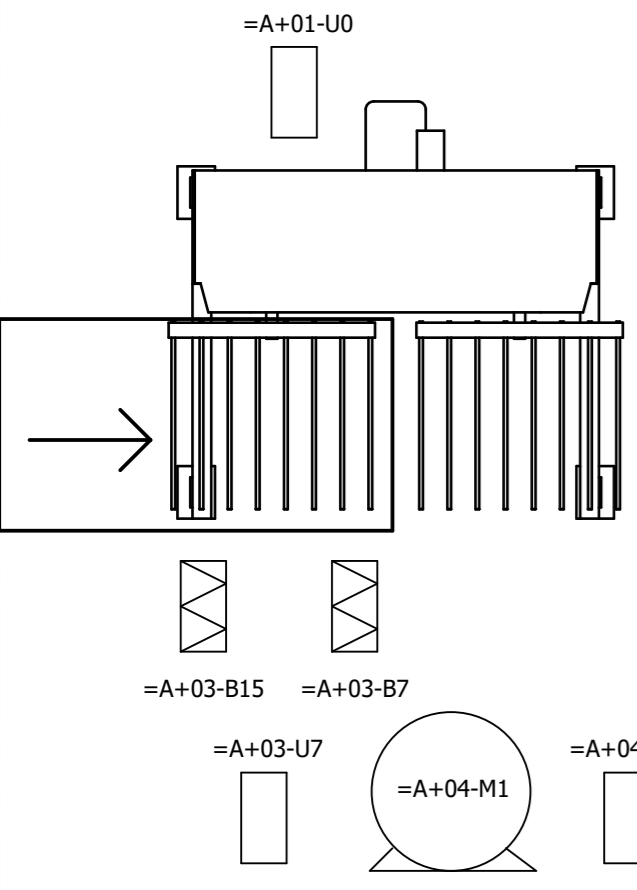

Legend:

Optional

- =A+04-M1 Drive infeed conveyor
- =A+04-U10 Drive control, infeed conveyor
- =A+03-B7 Product on infeed
- =A+03-B15 Product position monitoring
- =A+01-U0 Passive plug-in terminal Prorunner mk5
- =A+03-U7 T-coupler infeed

For technical specifications of gearmotor, applied options, machine configuration and other data see specification sheet.

Image may differ from reality.

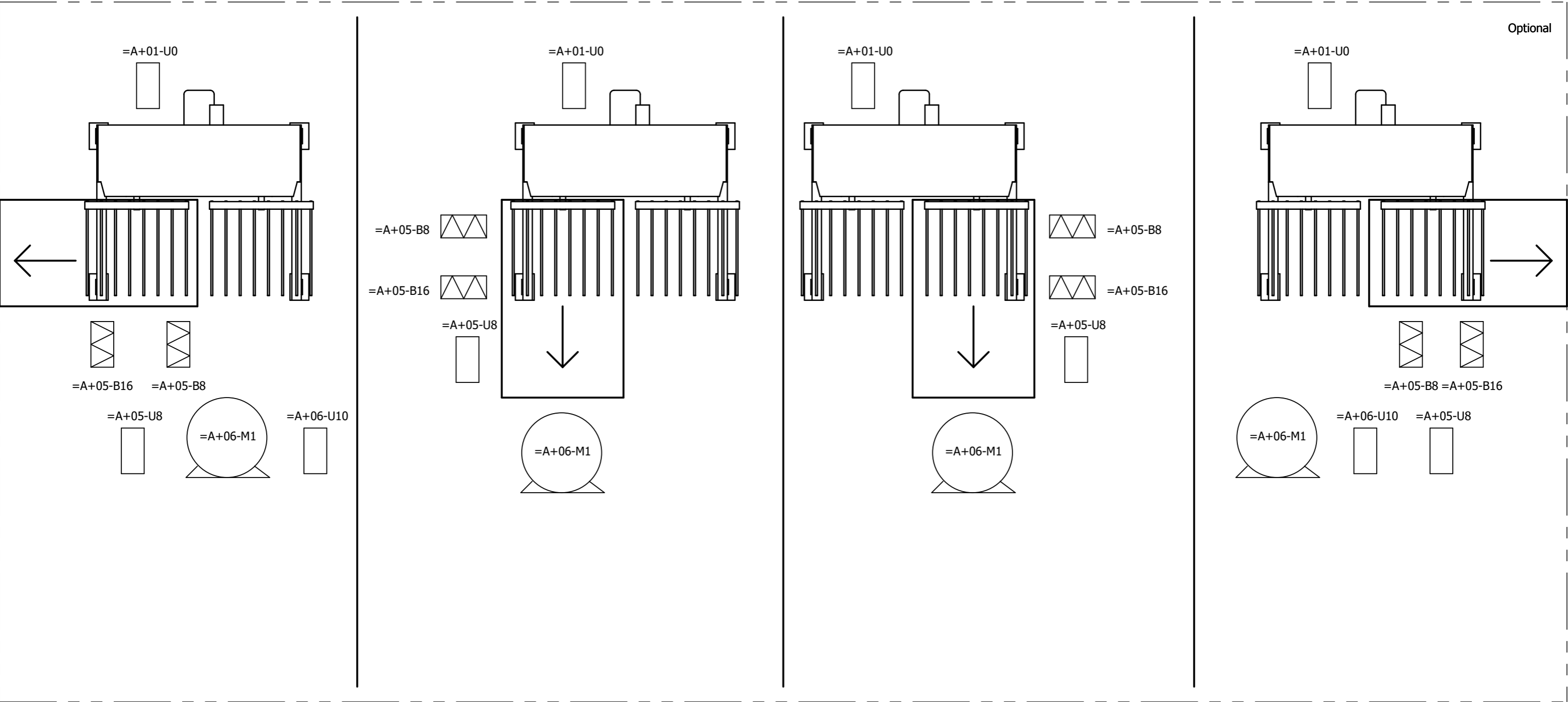

Legend:

Optional

- =A+06-M1 Drive outfeed conveyor
- =A+06-U10 Drive control, outfeed conveyor

- =A+05-B8 Product on outfeed
- =A+05-B16 Product has left the outfeed

- =A+01-U0 Passive plug-in terminal Prorunner mk5
- =A+05-U8 T-coupler outfeed

For technical specifications of gearmotor, applied options, machine configuration and other data see specification sheet.

Image may differ from reality.

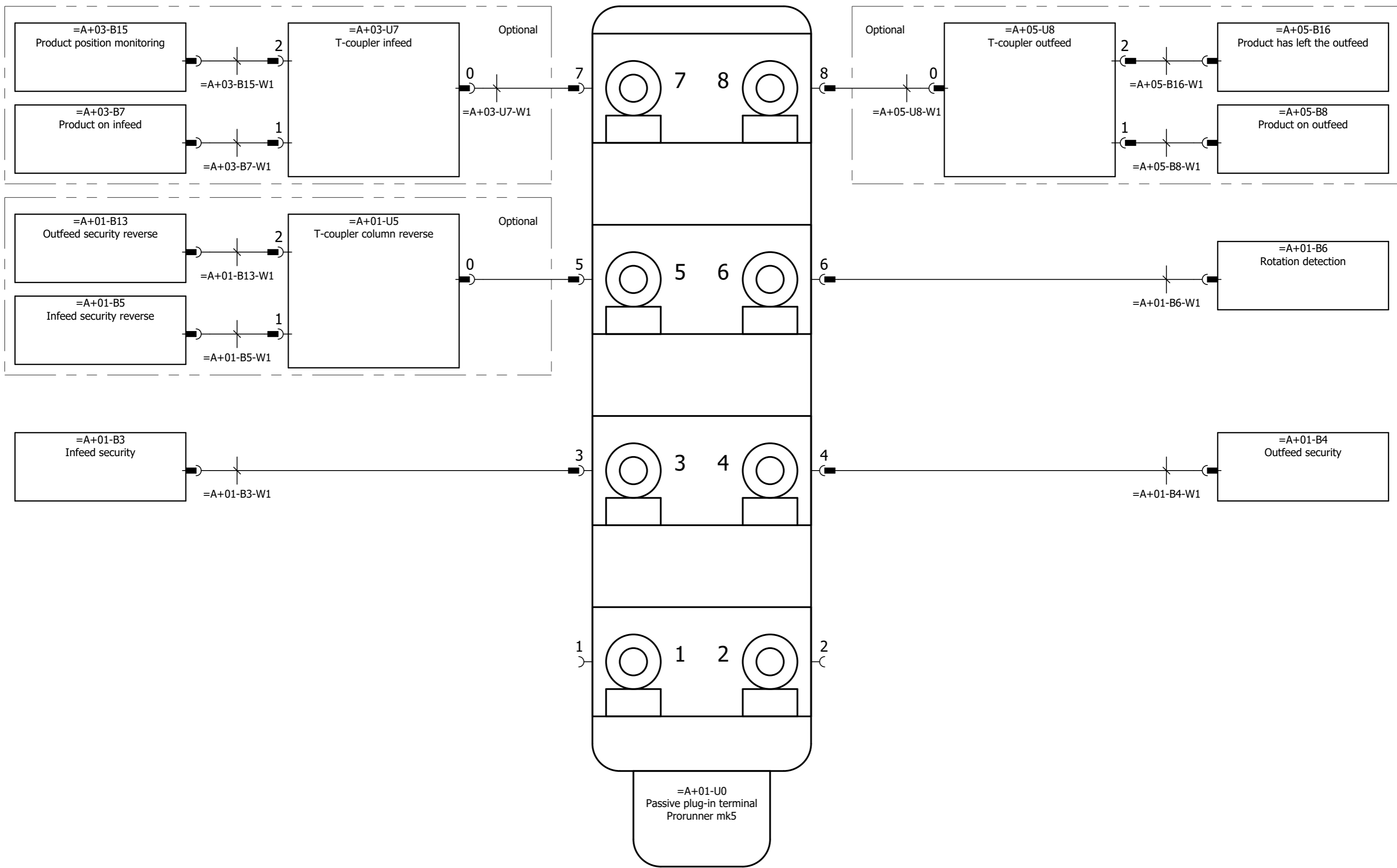

Application without encoder

For technical specifications of gearmotor, applied options, machine configuration and other data see specification sheet.

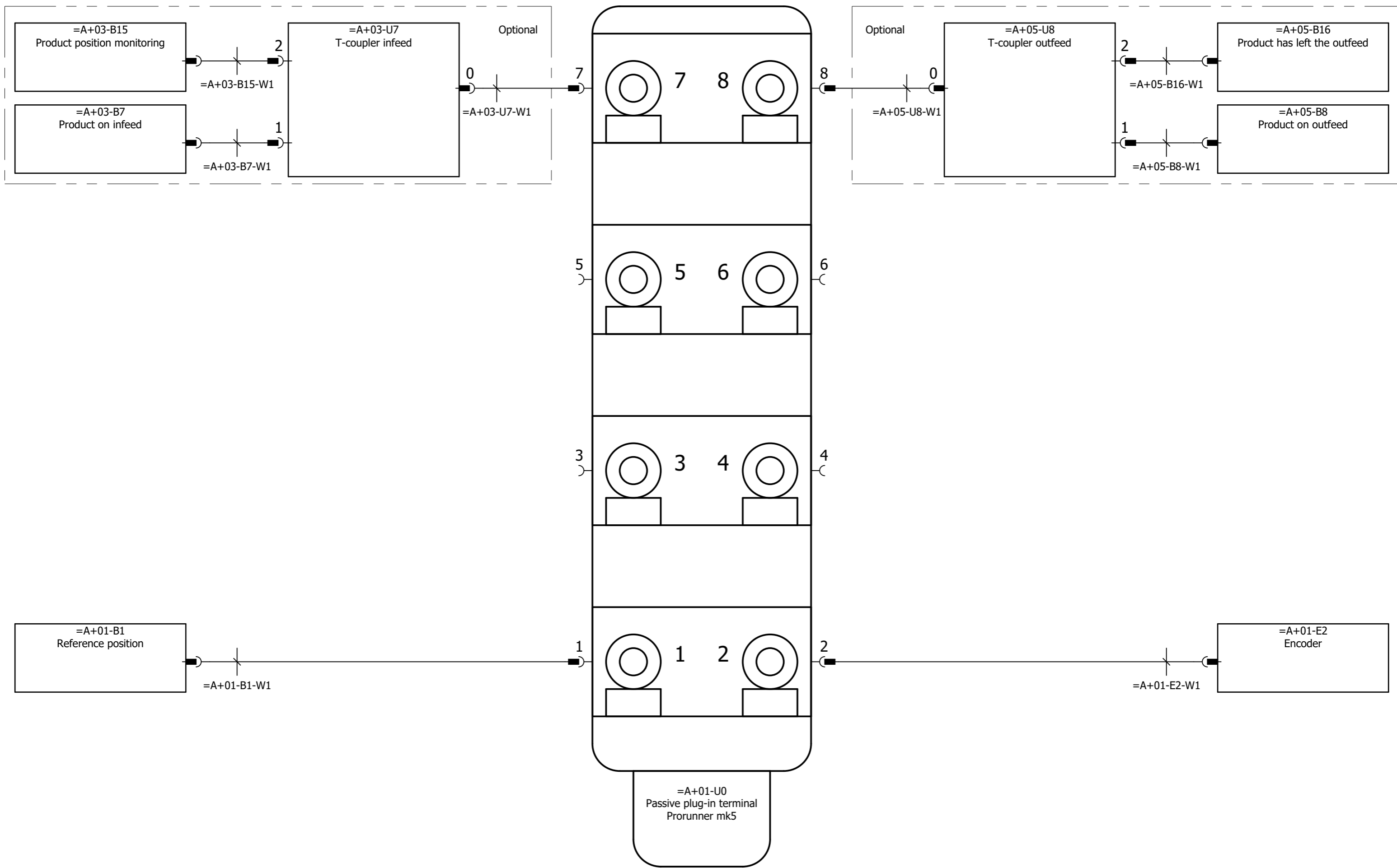

Application with encoder

For technical specifications of gearmotor, applied options, machine configuration and other data see specification sheet.

Parts list

Position	Quantity	Article number	Description	Manufacturer	Type number
+01-B1	1	1000932	Inductive proximity sensor	Sick	IME18-08BPSZC0K
+01-B1-W1	1	1001601	Prefab cable, PVC, 1 meter, connector M12 male 90°+ M12 female 90°, 4-pole	Murrelektronik	PVC-OB 4x0,34mm2
+01-B1-W1	1	1001528	Prefab cable, PVC, 2 meter, connector M12 male 90°+ M12 female 90°, 4-pole	Murrelektronik	PVC-OB 4x0,34mm2
+01-B3	1	1000932	Inductive proximity sensor	Sick	IME18-08BPSZC0K
+01-B3-W1	1	1001601	Prefab cable, PVC, 1 meter, connector M12 male 90°+ M12 female 90°, 4-pole	Murrelektronik	PVC-OB 4x0,34mm2
+01-B3-W1	1	1001326	Prefab cable, PVC, 5 meter, connector M12 male 90°+ M12 female 90°, 4-pole	Murrelektronik	PVC-OB 4x0,34mm2
+01-B3-W1	1	1001600	Prefab cable, PVC, 10 meter, connector M12 male 90°+ M12 female 90°, 4-pole	Murrelektronik	PVC-OB 4x0,34mm2
+01-B3-W1	1	1006487	Prefab cable, PVC, 15 meter, connector M12 male 90°+ M12 female 90°, 4-pole	Murrelektronik	PVC-OB 4x0,34mm2
+01-B3-W1	1	1006648	Prefab cable, PVC, 20 meter, connector M12 male 90°+ M12 female 90°, 4-pole	Murrelektronik	PVC-OB 4x0,34mm2
+01-B4	1	1000932	Inductive proximity sensor	Sick	IME18-08BPSZC0K
+01-B4-W1	1	1001601	Prefab cable, PVC, 1 meter, connector M12 male 90°+ M12 female 90°, 4-pole	Murrelektronik	PVC-OB 4x0,34mm2
+01-B4-W1	1	1001326	Prefab cable, PVC, 5 meter, connector M12 male 90°+ M12 female 90°, 4-pole	Murrelektronik	PVC-OB 4x0,34mm2
+01-B4-W1	1	1001600	Prefab cable, PVC, 10 meter, connector M12 male 90°+ M12 female 90°, 4-pole	Murrelektronik	PVC-OB 4x0,34mm2
+01-B4-W1	1	1006487	Prefab cable, PVC, 15 meter, connector M12 male 90°+ M12 female 90°, 4-pole	Murrelektronik	PVC-OB 4x0,34mm2
+01-B4-W1	1	1006648	Prefab cable, PVC, 20 meter, connector M12 male 90°+ M12 female 90°, 4-pole	Murrelektronik	PVC-OB 4x0,34mm2
+01-B5	1	1000932	Inductive proximity sensor	Sick	IME18-08BPSZC0K
+01-B5-W1	1	1001601	Prefab cable, PVC, 1 meter, connector M12 male 90°+ M12 female 90°, 4-pole	Murrelektronik	PVC-OB 4x0,34mm2
+01-B5-W1	1	1001326	Prefab cable, PVC, 5 meter, connector M12 male 90°+ M12 female 90°, 4-pole	Murrelektronik	PVC-OB 4x0,34mm2
+01-B5-W1	1	1001600	Prefab cable, PVC, 10 meter, connector M12 male 90°+ M12 female 90°, 4-pole	Murrelektronik	PVC-OB 4x0,34mm2
+01-B5-W1	1	1006487	Prefab cable, PVC, 15 meter, connector M12 male 90°+ M12 female 90°, 4-pole	Murrelektronik	PVC-OB 4x0,34mm2
+01-B5-W1	1	1006648	Prefab cable, PVC, 20 meter, connector M12 male 90°+ M12 female 90°, 4-pole	Murrelektronik	PVC-OB 4x0,34mm2
+01-B6	1	1000932	Inductive proximity sensor	Sick	IME18-08BPSZC0K
+01-B6-W1	1	1001601	Prefab cable, PVC, 1 meter, connector M12 male 90°+ M12 female 90°, 4-pole	Murrelektronik	PVC-OB 4x0,34mm2
+01-B13	1	1000932	Inductive proximity sensor	Sick	IME18-08BPSZC0K
+01-B13-W1	1	1001601	Prefab cable, PVC, 1 meter, connector M12 male 90°+ M12 female 90°, 4-pole	Murrelektronik	PVC-OB 4x0,34mm2
+01-B13-W1	1	1001326	Prefab cable, PVC, 5 meter, connector M12 male 90°+ M12 female 90°, 4-pole	Murrelektronik	PVC-OB 4x0,34mm2
+01-B13-W1	1	1001600	Prefab cable, PVC, 10 meter, connector M12 male 90°+ M12 female 90°, 4-pole	Murrelektronik	PVC-OB 4x0,34mm2
+01-B13-W1	1	1006487	Prefab cable, PVC, 15 meter, connector M12 male 90°+ M12 female 90°, 4-pole	Murrelektronik	PVC-OB 4x0,34mm2
+01-B13-W1	1	1006648	Prefab cable, PVC, 20 meter, connector M12 male 90°+ M12 female 90°, 4-pole	Murrelektronik	PVC-OB 4x0,34mm2
+01-E2	1		See specification sheet		
+01-E2-W1	1	1001326	Prefab cable, PVC, 5 meter, connector M12 male 90°+ M12 female 90°, 4-pole	Murrelektronik	PVC-OB 4x0,34mm2
+01-E2-W1	1	1001600	Prefab cable, PVC, 10 meter, connector M12 male 90°+ M12 female 90°, 4-pole	Murrelektronik	PVC-OB 4x0,34mm2
+01-E2-W1	1	1006487	Prefab cable, PVC, 15 meter, connector M12 male 90°+ M12 female 90°, 4-pole	Murrelektronik	PVC-OB 4x0,34mm2
+01-E2-W1	1	1006648	Prefab cable, PVC, 20 meter, connector M12 male 90°+ M12 female 90°, 4-pole	Murrelektronik	PVC-OB 4x0,34mm2
+01-U0	1	1003309	Passive plug-in terminal, 8-fold, 5-pole, M12	Murrelektronik	Exact12 8xM12 5-p
+01-U5	1	1003313	T-Coupler 5p Male M12 / 2x 4p Female M12	Murrelektronik	T-Coupler5p Male M12 / 2x 4p Female M12

Parts list

Position	Quantity	Article number	Description	Manufacturer	Type number
+02-M1	1		See specification sheet		
+03-B7	1	1005663	Reflex sensor	Sick	GL6-P4211
+03-B7	1	1002242	Reflector	Sick	C42-2
+03-B7	1	AE0036129	Reflective tape	Sick	REF-PLUS-R50
+03-B7	1	1003365	Proximity sensor	Sick	GTB6-P4211
+03-B7-W1	1	1003307	Prefab cable, PVC, 1 meter, connector M12 male + female M8, 4-pole	Murrelektronik	PVC-OB 4x0,25mm2
+03-B15	1	1005663	Reflex sensor	Sick	GL6-P4211
+03-B15	1	1002242	Reflector	Sick	C42-2
+03-B15	1	AE0036129	Reflective tape	Sick	REF-PLUS-R50
+03-B15	1	1003365	Proximity sensor	Sick	GTB6-P4211
+03-B15-W1	1	1003307	Prefab cable, PVC, 1 meter, connector M12 male + female M8, 4-pole	Murrelektronik	PVC-OB 4x0,25mm2
+03-U7	1	1003313	T-Coupler 5p Male M12 / 2x 4p Female M12	Murrelektronik	T-Coupler5p Male M12 / 2x 4p Female M12
+03-U7-W1	1	1001326	Prefab cable, PVC, 5 meter, connector M12 male 90°+ M12 female 90°, 4-pole	Murrelektronik	PVC-OB 4x0,34mm2
+03-U7-W1	1	1001600	Prefab cable, PVC, 10 meter, connector M12 male 90°+ M12 female 90°, 4-pole	Murrelektronik	PVC-OB 4x0,34mm2
+03-U7-W1	1	1006487	Prefab cable, PVC, 15 meter, connector M12 male 90°+ M12 female 90°, 4-pole	Murrelektronik	PVC-OB 4x0,34mm2
+03-U7-W1	1	1006648	Prefab cable, PVC, 20 meter, connector M12 male 90°+ M12 female 90°, 4-pole	Murrelektronik	PVC-OB 4x0,34mm2
+04-M1	1		See specification sheet		
+04-U10	1		See specification sheet		
+05-B8	1	1005663	Reflex sensor	Sick	GL6-P4211
+05-B8	1	1002242	Reflector	Sick	C42-2
+05-B8	1	AE0036129	Reflective tape	Sick	REF-PLUS-R50
+05-B8	1	1003365	Proximity sensor	Sick	GTB6-P4211
+05-B8-W1	1	1003307	Prefab cable, PVC, 1 meter, connector M12 male + female M8, 4-pole	Murrelektronik	PVC-OB 4x0,25mm2
+05-B16	1	1005663	Reflex sensor	Sick	GL6-P4211
+05-B16	1	1002242	Reflector	Sick	C42-2
+05-B16	1	AE0036129	Reflective tape	Sick	REF-PLUS-R50
+05-B16	1	1003365	Proximity sensor	Sick	GTB6-P4211
+05-B16-W1	1	1003307	Prefab cable, PVC, 1 meter, connector M12 male + female M8, 4-pole	Murrelektronik	PVC-OB 4x0,25mm2
+05-U8	1	1003313	T-Coupler 5p Male M12 / 2x 4p Female M12	Murrelektronik	T-Coupler5p Male M12 / 2x 4p Female M12
+05-U8-W1	1	1001326	Prefab cable, PVC, 5 meter, connector M12 male 90°+ M12 female 90°, 4-pole	Murrelektronik	PVC-OB 4x0,34mm2
+05-U8-W1	1	1001600	Prefab cable, PVC, 10 meter, connector M12 male 90°+ M12 female 90°, 4-pole	Murrelektronik	PVC-OB 4x0,34mm2
+05-U8-W1	1	1006487	Prefab cable, PVC, 15 meter, connector M12 male 90°+ M12 female 90°, 4-pole	Murrelektronik	PVC-OB 4x0,34mm2
+05-U8-W1	1	1006648	Prefab cable, PVC, 20 meter, connector M12 male 90°+ M12 female 90°, 4-pole	Murrelektronik	PVC-OB 4x0,34mm2
+06-M1	1		See specification sheet		
+06-U10	1		See specification sheet		

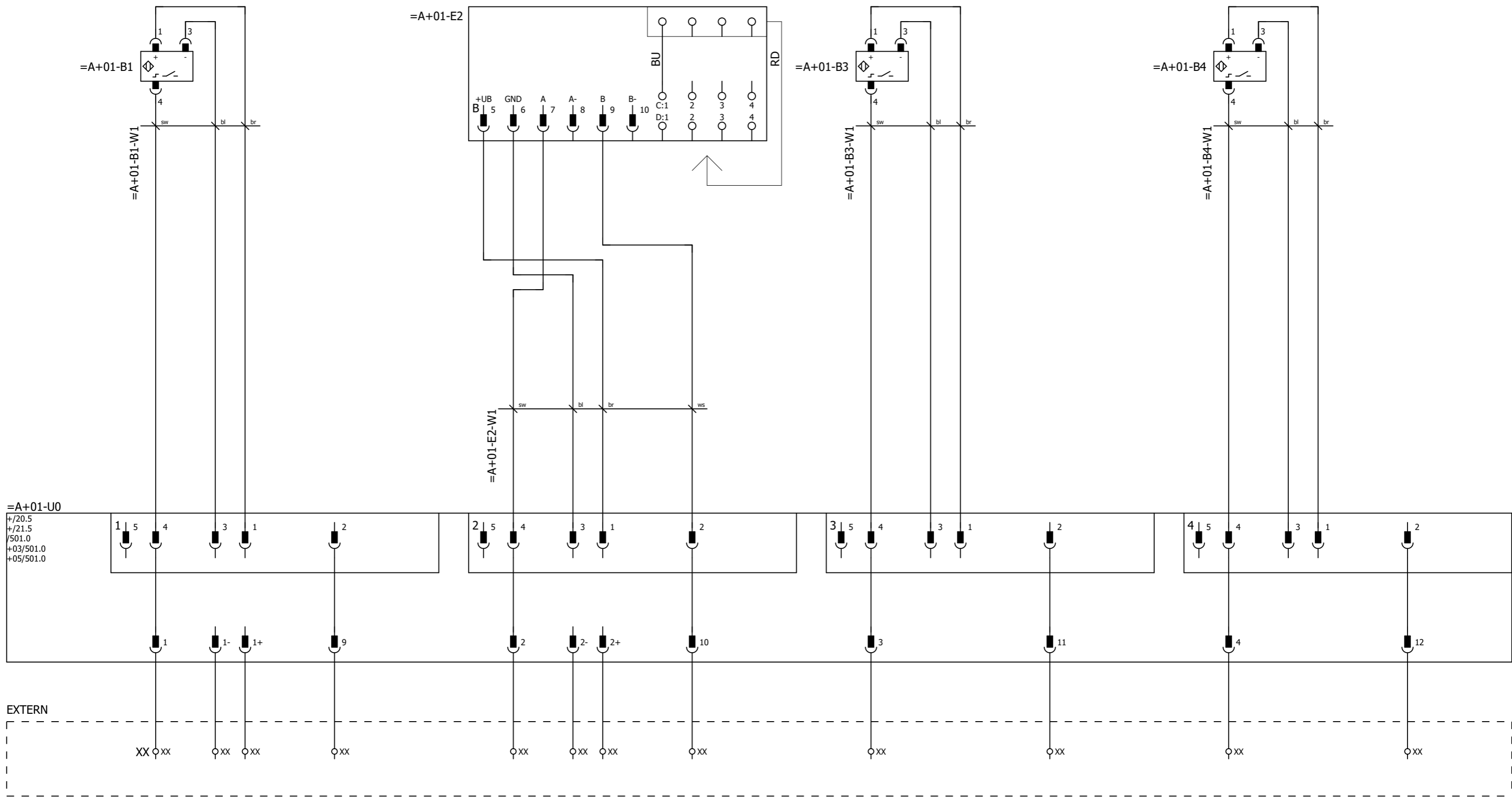

Passive plug-in terminal Prorunner mk5

Reference position Spare Encoder signal A Encoder signal B Infeed security Spare Outfeed security Spare

EXTERN

Alternative

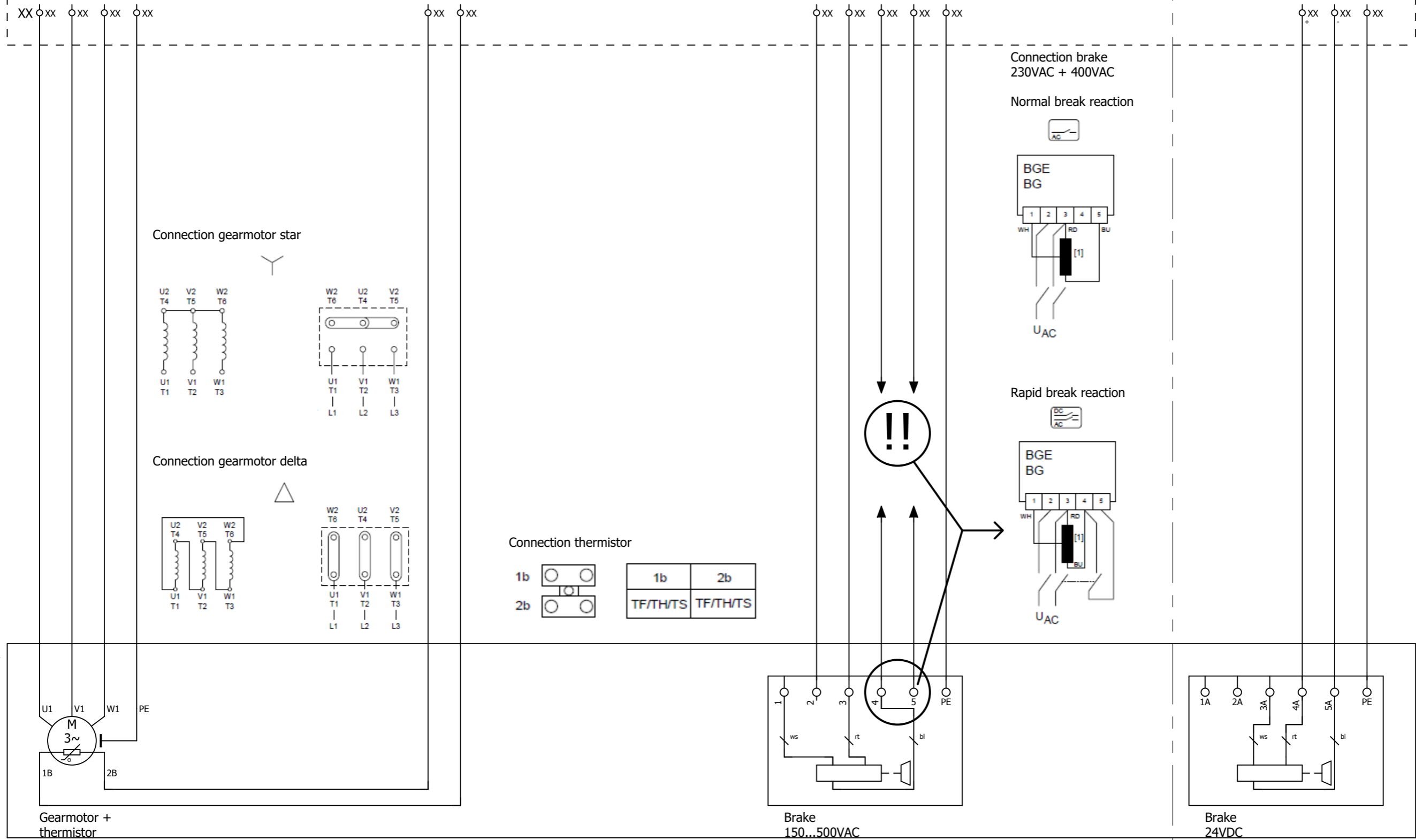

=A+02-M1

Gearmotor + thermistor

Brake 150...500VAC

Brake 24VDC

Gearmotor Prorunner mk5

For technical specifications of gearmotor, applied options, machine configuration and other data see specification sheet.

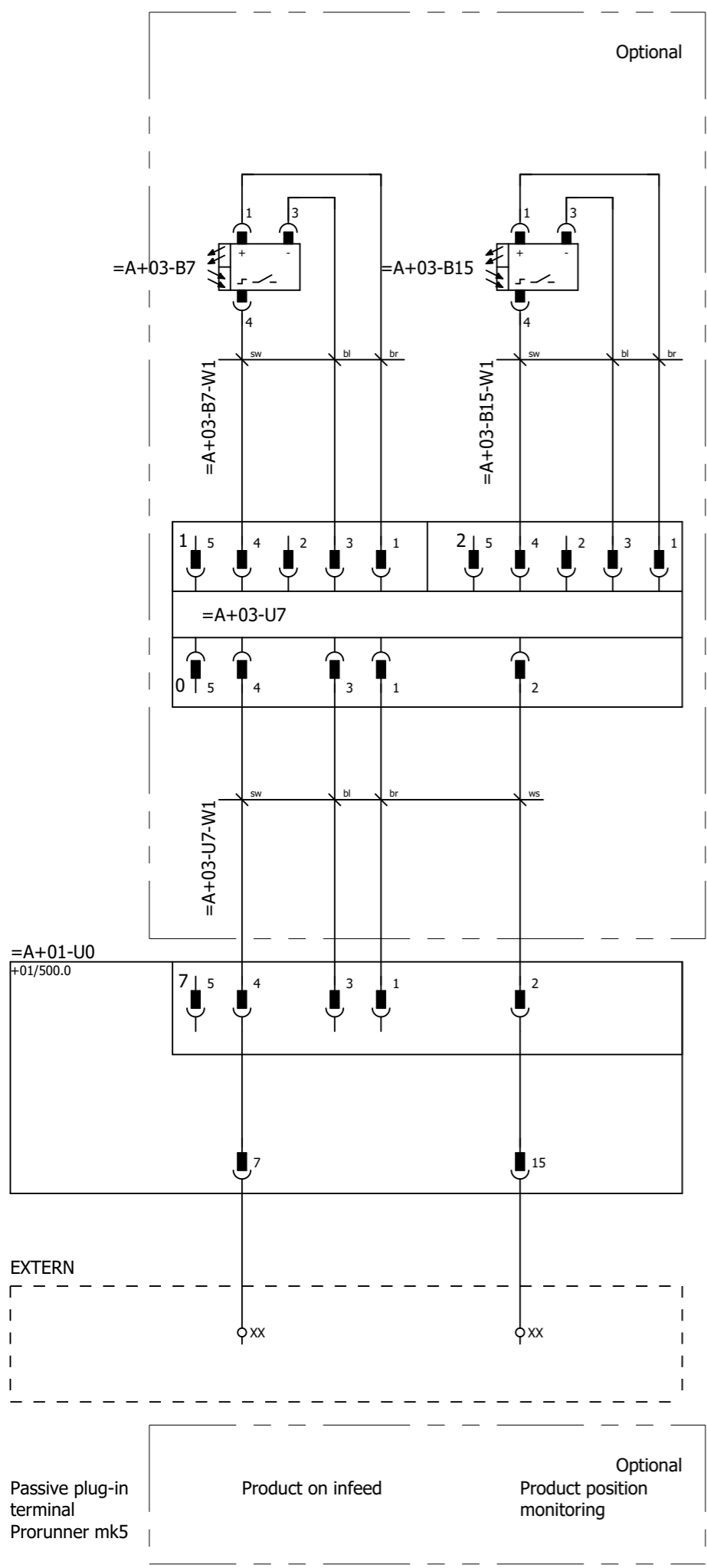

For technical specifications of gearmotor, applied options, machine configuration and other data see specification sheet.

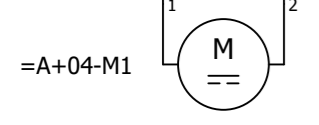
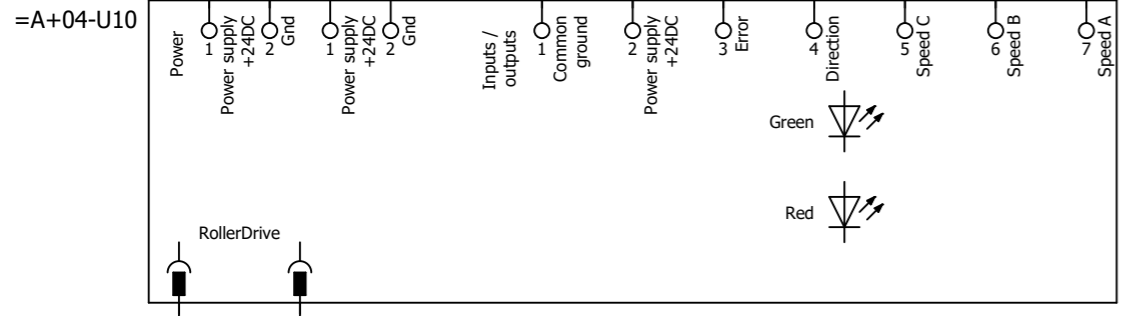
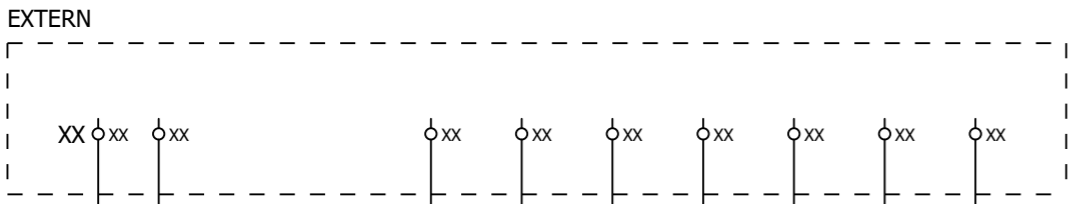

Rollerdrive infeed conveyor

For technical specifications of gearmotor, applied options, machine configuration and other data see specification sheet.

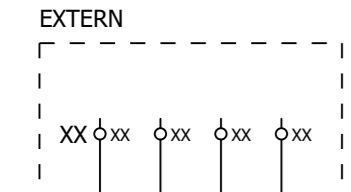

Connection gearmotor star

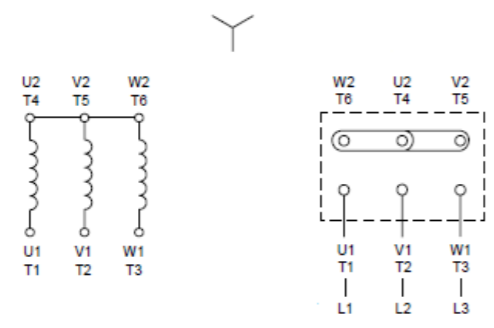

Connection gearmotor delta

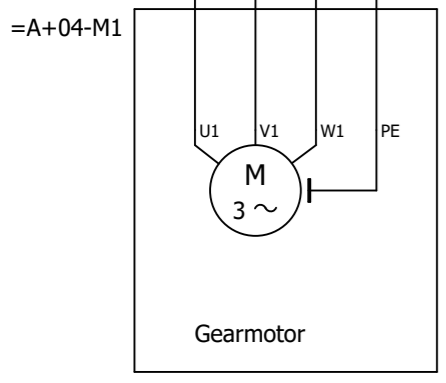
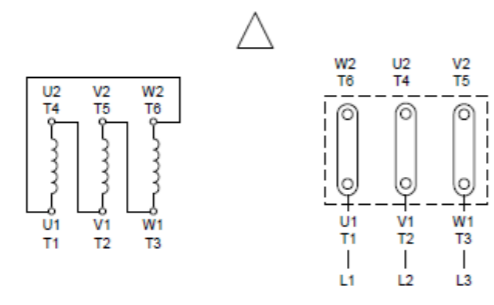

Gearmotor infeed conveyor

Optional

Alternative for Rollerdrive infeed conveyor

For technical specifications of gearmotor, applied options, machine configuration and other data see specification sheet.

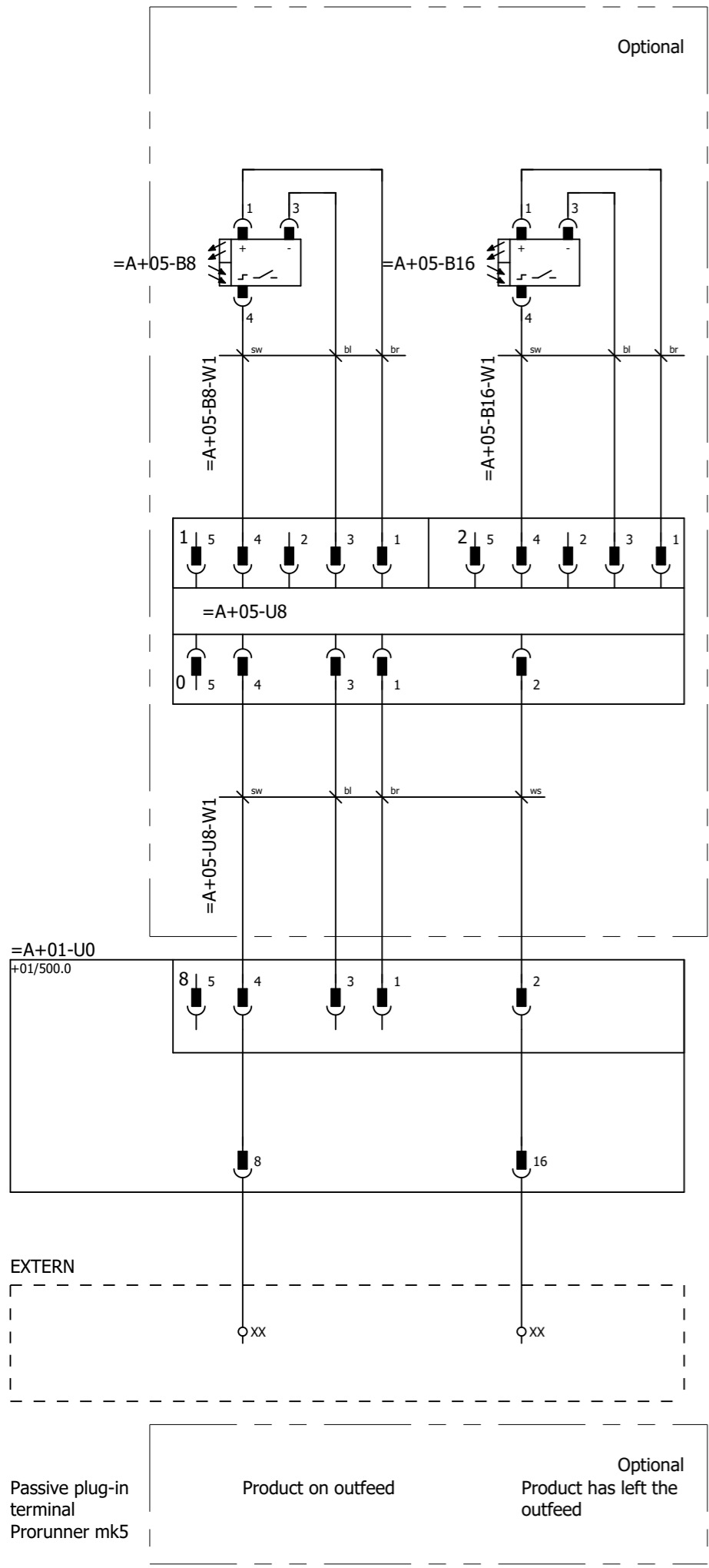

For technical specifications of gearmotor, applied options, machine configuration and other data see specification sheet.

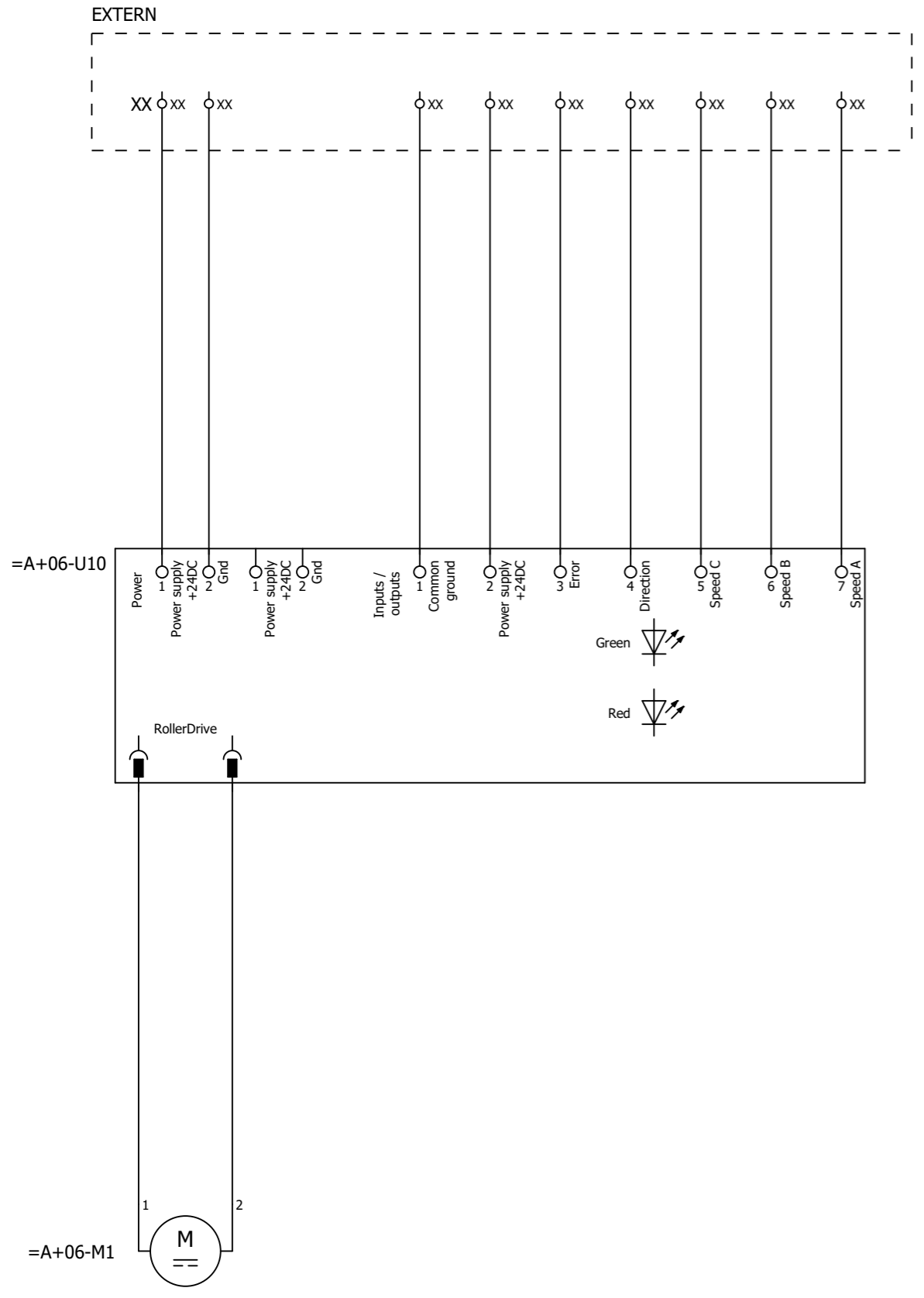

Rollerdrive outfeed conveyor

For technical specifications of gearmotor, applied options, machine configuration and other data see specification sheet.

EXTERN

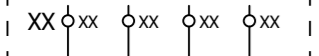

Connection gearmotor star

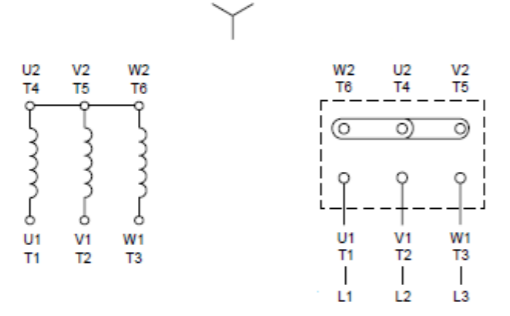

Connection gearmotor delta

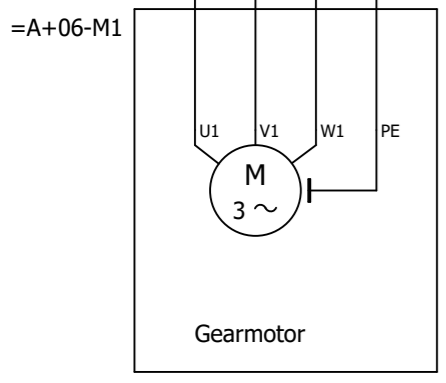
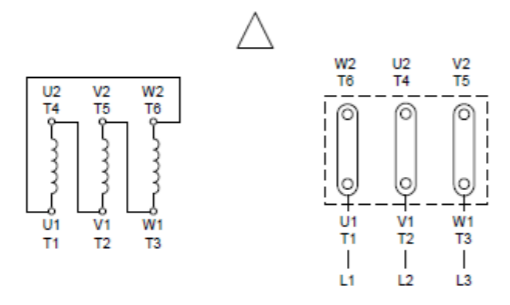

Gearmotor outfeed conveyor

Optional

Alternative for Rollerdrive outfeed conveyor

For technical specifications of gearmotor, applied options, machine configuration and other data see specification sheet.



Description of the project
Prorunner mk5 (XL)
Standard

Page description
Gearmotor, 3 fase

Mounting group Prorunner mk5 (XL)
Mounting location Drive outfeed conveyor

Ed.	DSP	=	A
Date	19-9-2018	+	06
Version	v4.5		Page 150