



Nobelstraat 43
3846 CE Harderwijk
The Netherlands

Phone: +31 341 - 436700
Fax: +31 341 - 436701
www.qimarox.com
info@qimarox.com

Document name: Electrical drawings PRmk5 (XL) Sorter conveyors v4.5.2
Mounting group: RDC3 infeed
Type: Standard

Power supply: See specification sheet
Control voltage: 24VDC
According to: NEN-EN-IEC 60204-1: 2018

Version number: v4.5.2

Table of contents

Mounting group		Mounting location		Page	Page description
=B	RDC3 infeed			1	Title page
				2	Table of contents
				10	Layout RollerDrive conveyor RDC3 infeed
				20	Overview passive plug-in terminal RDC3 infeed
				2000	Parts list
		+01	Detection	500	Field components
		+01	Detection	501	Field components
		+03	Drive conveyor	100	Rollerdrive, 24VDC

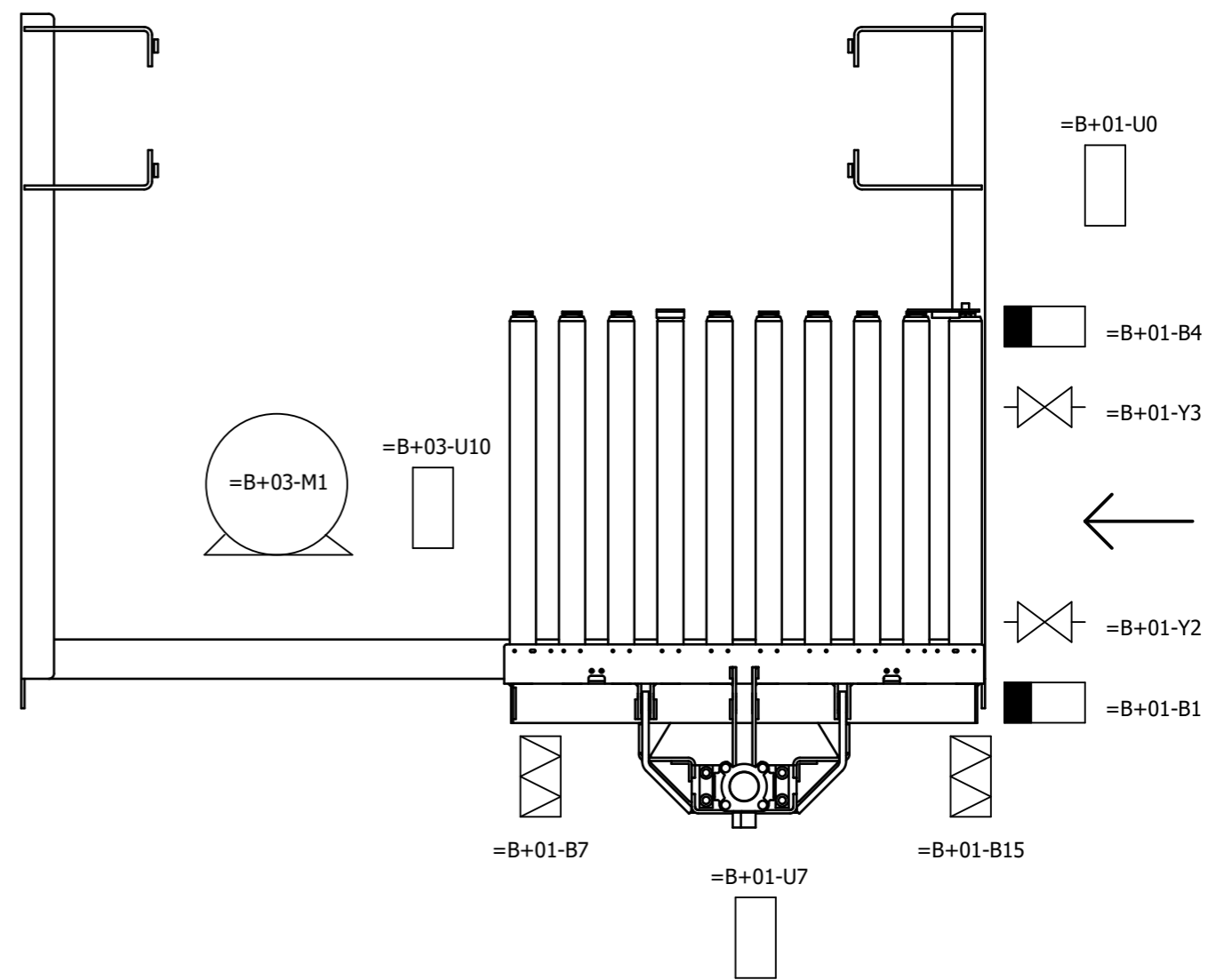
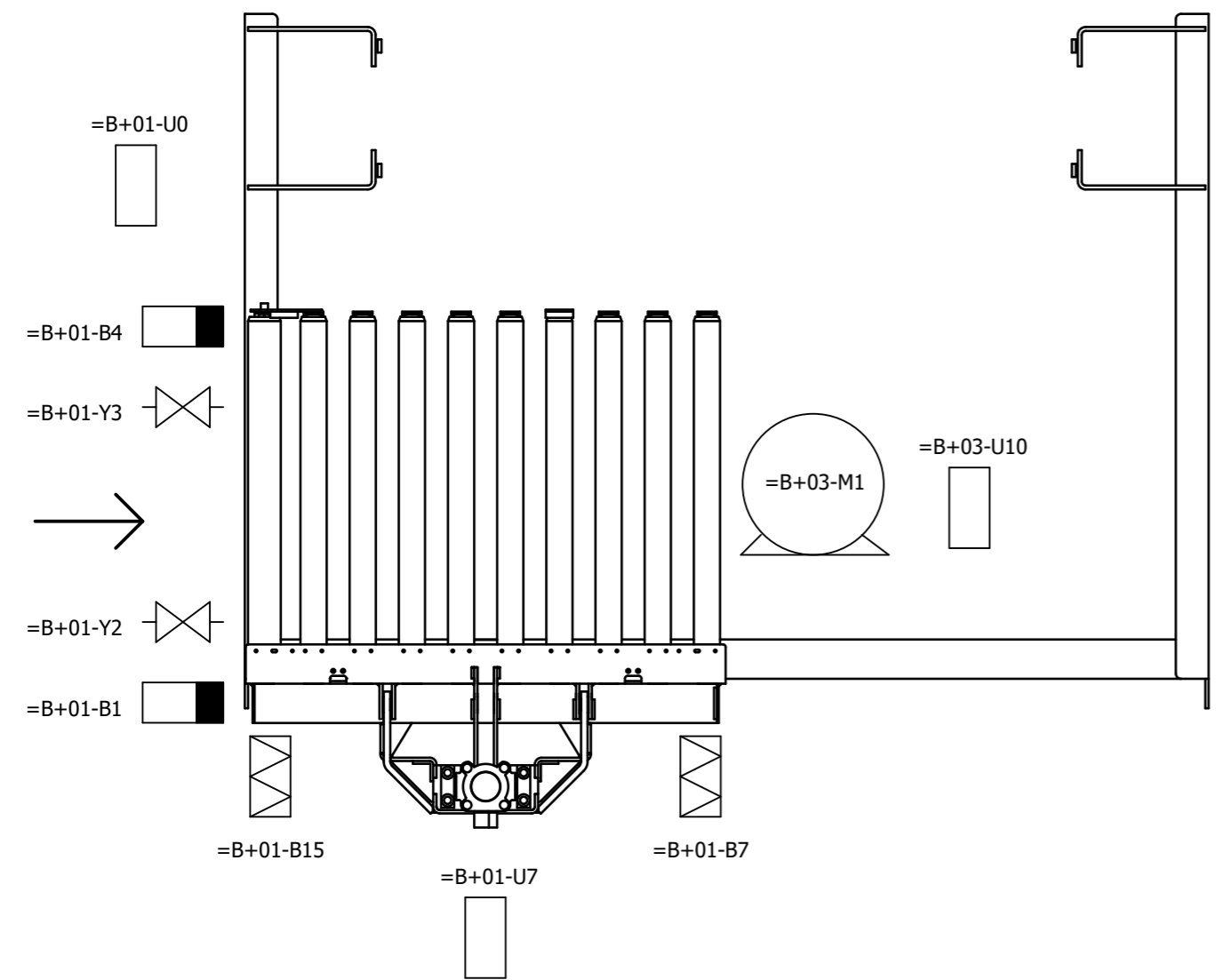

Legend:

- =B+03-M1 Drive RollerDrive conveyor infeed
- =B+03-U10 Drive control, moveable infeed conveyor

- =B+01-B1 Wait position
- =B+01-Y2 Movement to wait position
- =B+01-Y3 Movement to infeed position
- =B+01-B4 Infeed position
- =B+01-B7 Product on infeed
- =B+01-B15 Product position monitoring

- =B+01-U0 Passive plug-in terminal RollerDrive conveyor RDC3 infeed
- =B+01-U7 T-coupler infeed

For technical specifications of gearmotor, applied options, machine configuration and other data see specification sheet.

Image may differ from reality.

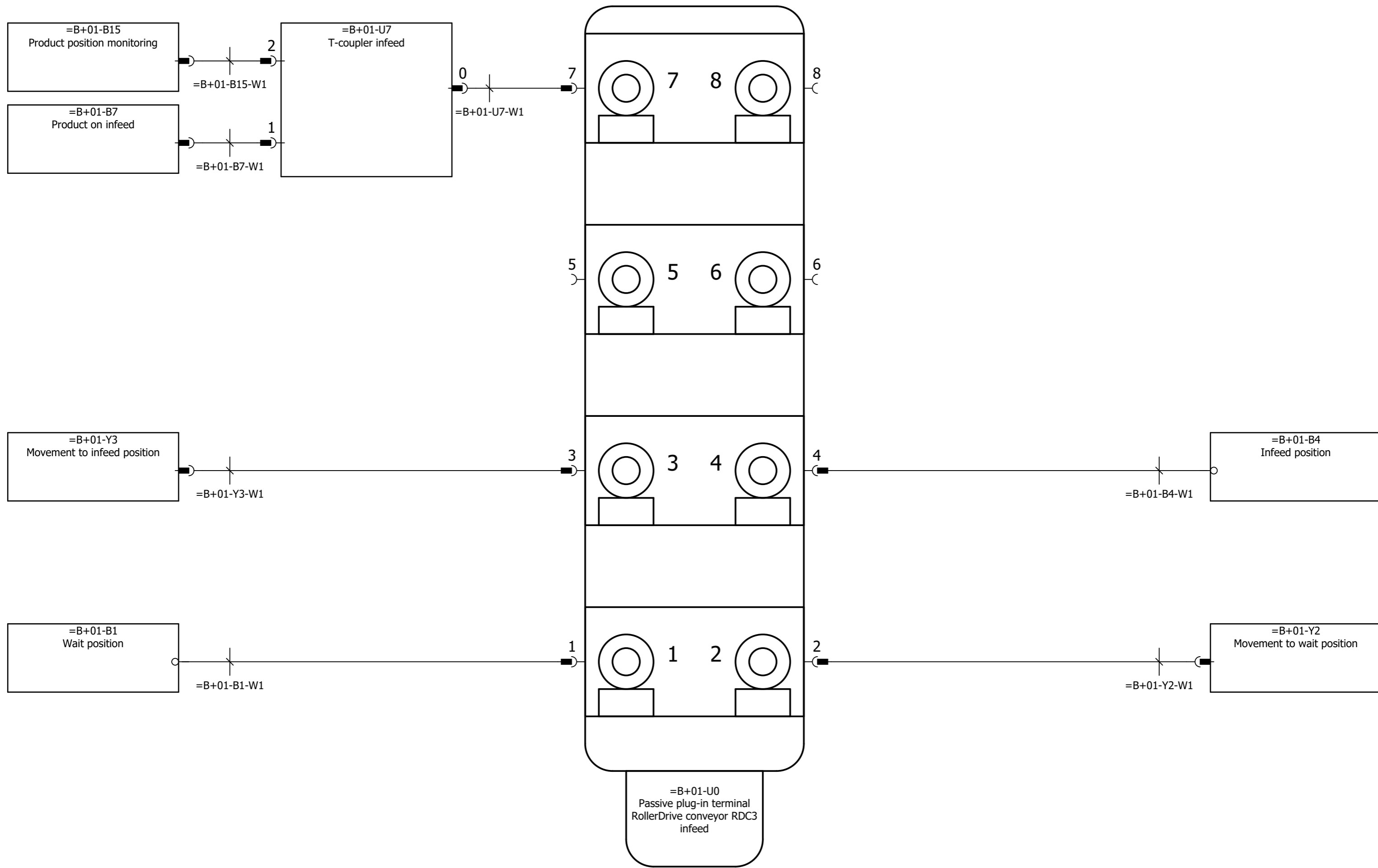

For technical specifications of gearmotor, applied options, machine configuration and other data see specification sheet.

Parts list

Position	Quantity	Article number	Description	Manufacturer	Type number
+01-B1	1	1007850	Proximity Sensor	Festo	SMT-8M-A-PS-24V-E-1-N-M12
+01-B4	1	1007850	Proximity Sensor	Festo	SMT-8M-A-PS-24V-E-1-N-M12
+01-B7	1	1005663	Reflex sensor	Sick	GL6-P4211
+01-B7	1	1002242	Reflector	Sick	C42-2
+01-B7-W1	1	1003307	Prefab cable, PVC, 1 meter, connector M12 male + female M8, 4-pole	Murrelektronik	PVC-OB 4x0,25mm2
+01-B15	1	1005663	Reflex sensor	Sick	GL6-P4211
+01-B15	1	1002242	Reflector	Sick	C42-2
+01-B15-W1	1	1003307	Prefab cable, PVC, 1 meter, connector M12 male + female M8, 4-pole	Murrelektronik	PVC-OB 4x0,25mm2
+01-U0	1	1003309	Passive plug-in terminal, 8-fold, 5-pole, M12	Murrelektronik	Exact12 8xM12 5-p
+01-U7	1	1003313	T-Coupler 5p Male M12 / 2x 4p Female M12, Distribution function	Murrelektronik	T-Coupler5p Male M12 / 2x 4p Female M12
+01-U7-W1	1	1001601	Prefab cable, PVC, 1 meter, connector M12 male 90°+ M12 female 90°, 4-pole	Murrelektronik	PVC-OB 4x0,34mm2
+01-Y2	1		See specification sheet		
+01-Y2-W1	1	1005959	Prefab cable, PVC, 0,3 meter, connector M12 male + female M8 straight 90°, 3-pole	Murrelektronik	PVC-OB 3x0,25mm2
+01-Y3	1		See specification sheet		
+01-Y3-W1	1	1005959	Prefab cable, PVC, 0,3 meter, connector M12 male + female M8 straight 90°, 3-pole	Murrelektronik	PVC-OB 3x0,25mm2
+03-M1	1		See specification sheet		
+03-U10	1		See specification sheet		

For technical specifications of gearmotor, applied options, machine configuration and other data see specification sheet.

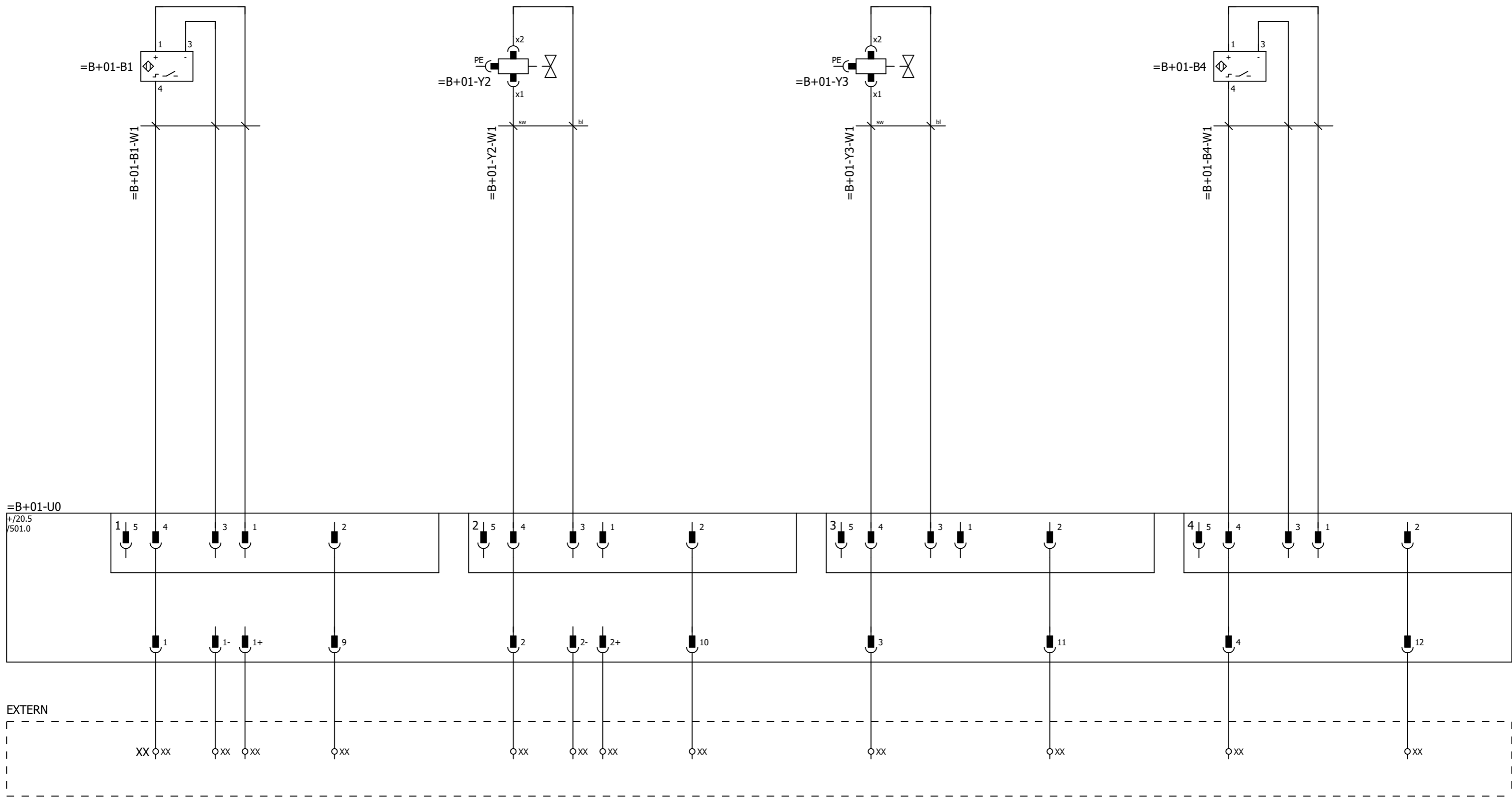

Passive plug-in terminal RollerDrive conveyor RDC3 infeed

Wait position Spare Movement to wait position Spare Movement to infeed position Spare Infeed position Spare



Description of the project
PRmk5 (XL) Sorter conveyors
Standard

Page description
Field components

Mounting group RDC3 infeed
Mounting location Detection

Ed.	DSP	=	B
Date	20-12-2021	+	01
Version	v4.5.2		
			Page 500

For technical specifications of gearmotor, applied options, machine configuration and other data see specification sheet.

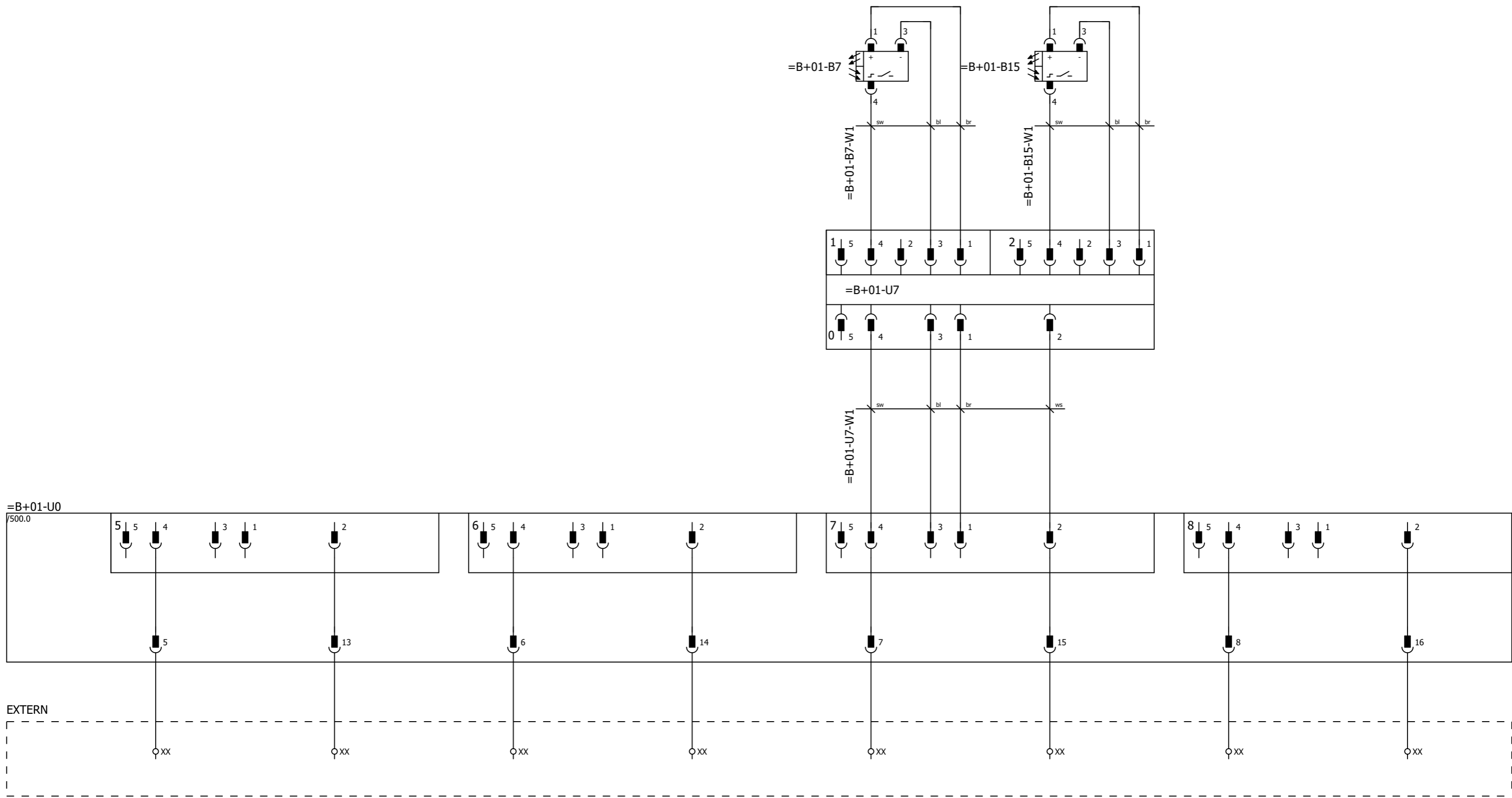

Passive plug-in terminal RollerDrive conveyor RDC3 infeed Spare Spare Spare Spare Product on infeed Product position monitoring Spare Spare



Description of the project
PRmk5 (XL) Sorter conveyors
Standard

Page description
Field components

Mounting group RDC3 infeed
Mounting location Detection

Ed.	DSP	=	B
Date	20-12-2021	+	01
Version	v4.5.2		
			Page 501

0 1 2 3 4 5 6 7 8 9

EXTERN

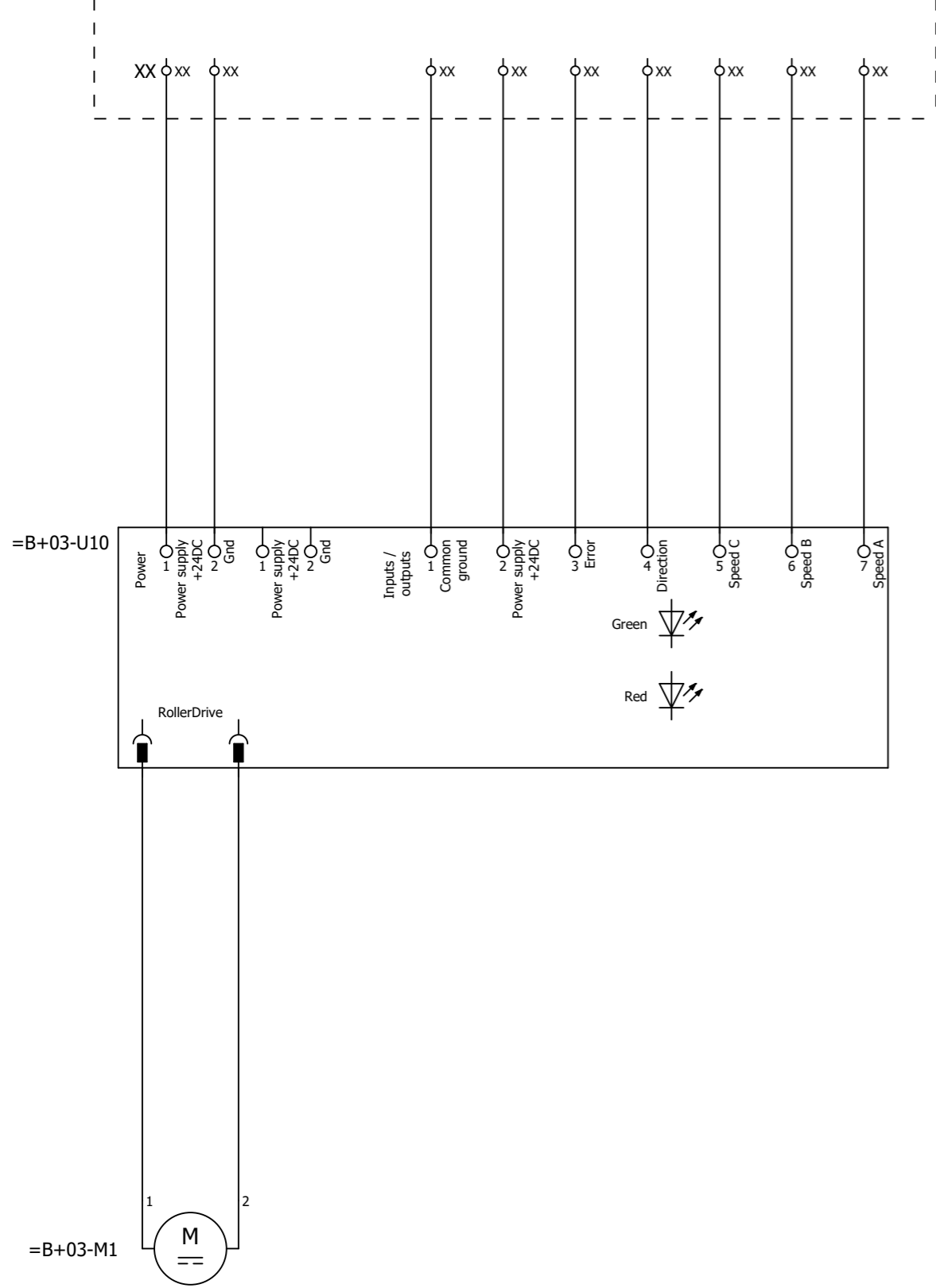

RollerDrive conveyor infeed

For technical specifications of gearmotor, applied options, machine configuration and other data see specification sheet.



Nobelstraat 43
3846 CE Harderwijk
The Netherlands

Phone: +31 341 - 436700
Fax: +31 341 - 436701
www.qimarox.com
info@qimarox.com

Document name: Electrical drawings PRmk5 (XL) Sorter conveyors v4.5.2
Mounting group: RDC3 outfeed
Type: Standard

Power supply: See specification sheet
Control voltage: 24VDC
According to: NEN-EN-IEC 60204-1: 2018

Version number: v4.5.2

Table of contents

Mounting group		Mounting location		Page	Page description
=C	RDC3 outfeed			1	Title page
				2	Table of contents
				10	Layout RollerDrive conveyor RDC3 outfeed
				20	Overview passive plug-in terminal RDC3 outfeed
				2000	Parts list
		+01	Detection	500	Field components
		+01	Detection	501	Field components
		+03	Drive conveyor	100	Rollerdrive, 24VDC

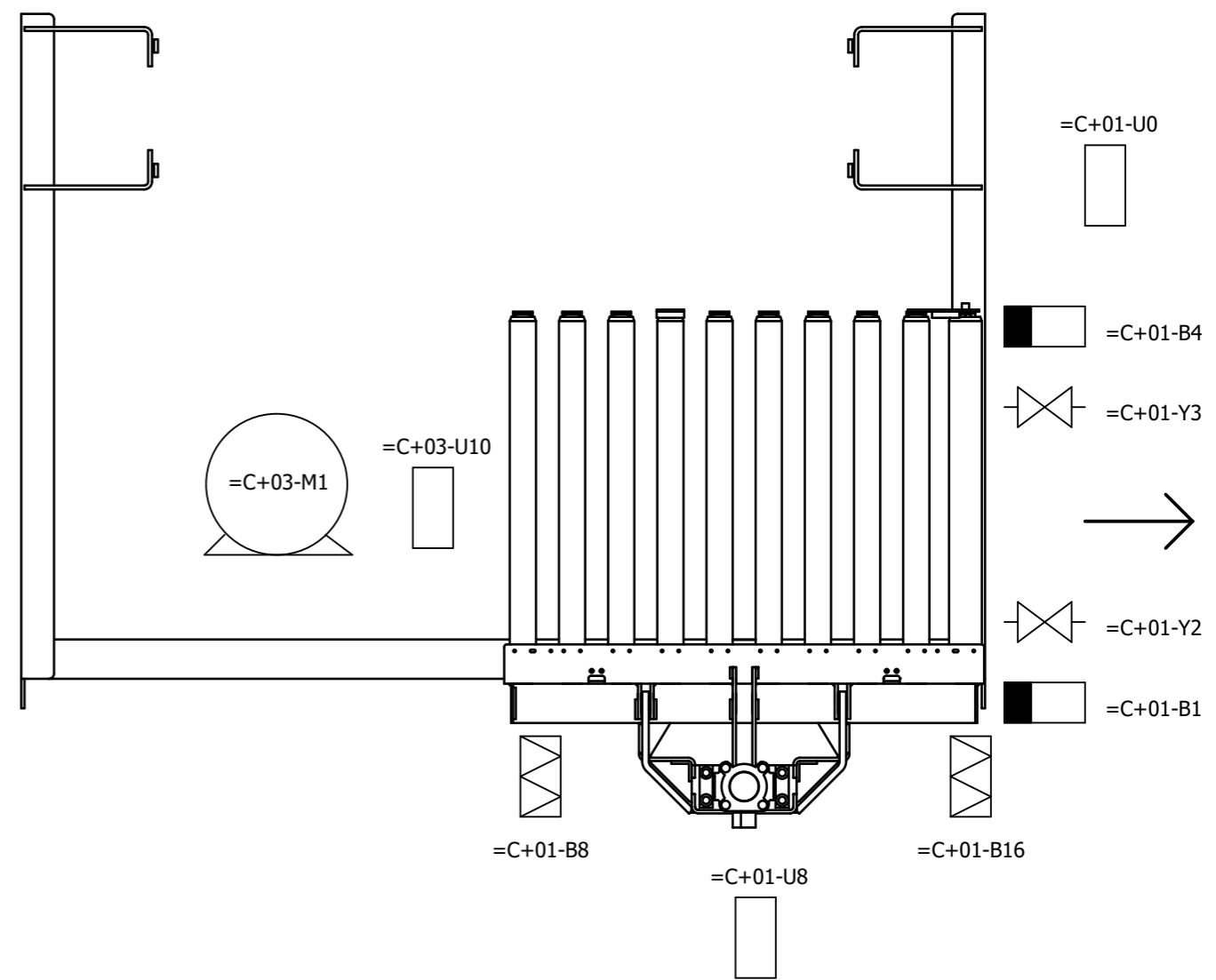
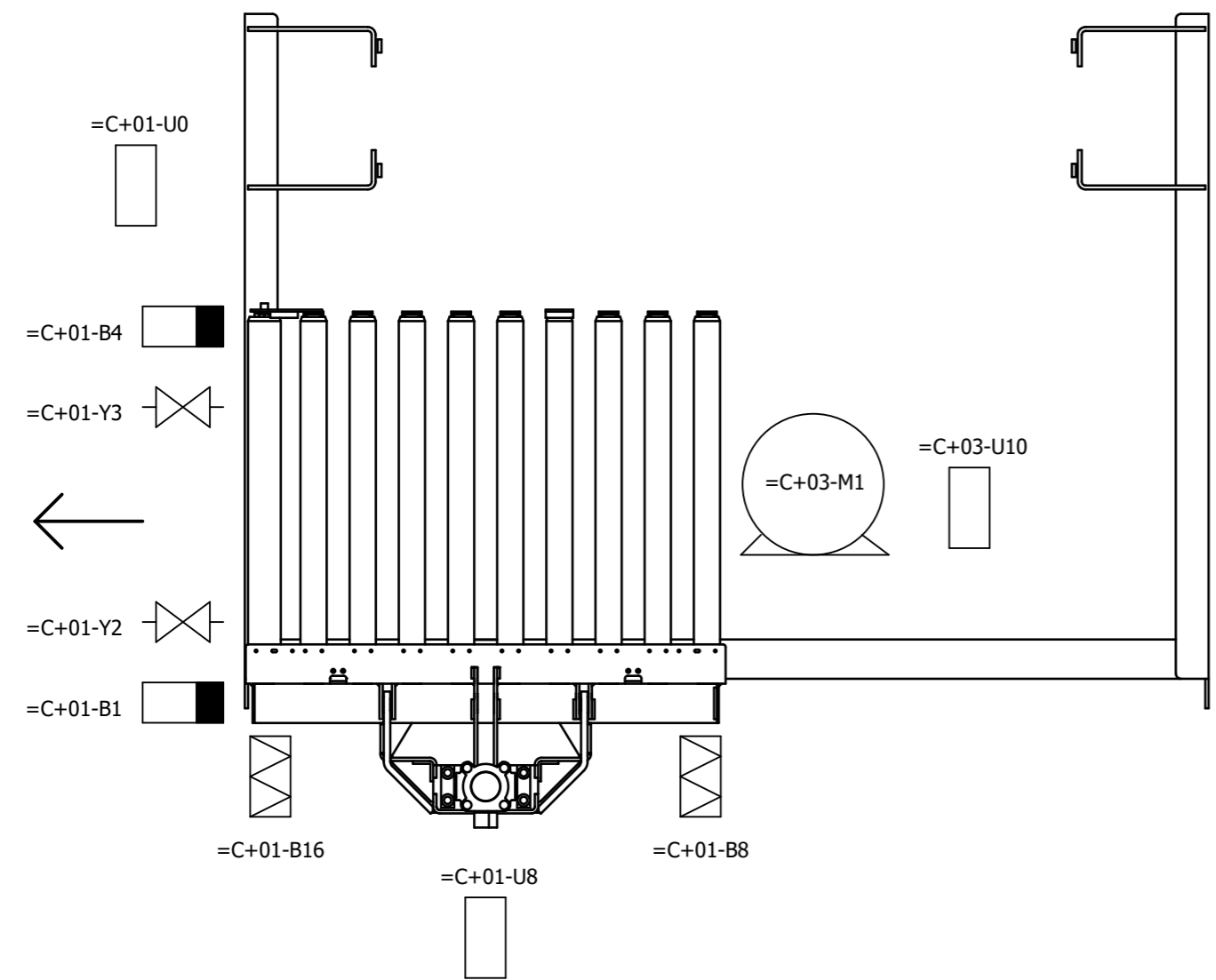

Legend:

- =C+03-M1 Drive RollerDrive conveyor outfeed
- =C+03-U10 Drive control, moveable outfeed conveyor

- =C+01-B1 Wait position
- =C+01-Y2 Movement to wait position
- =C+01-Y3 Movement to outfeed position
- =C+01-B4 Outfeed position
- =C+01-B8 Product on outfeed
- =C+01-B16 Product has left the outfeed

- =C+01-U0 Passive plug-in terminal RollerDrive conveyor RDC3 outfeed
- =C+01-U8 T-coupler outfeed

For technical specifications of gearmotor, applied options, machine configuration and other data see specification sheet.

Image may differ from reality.

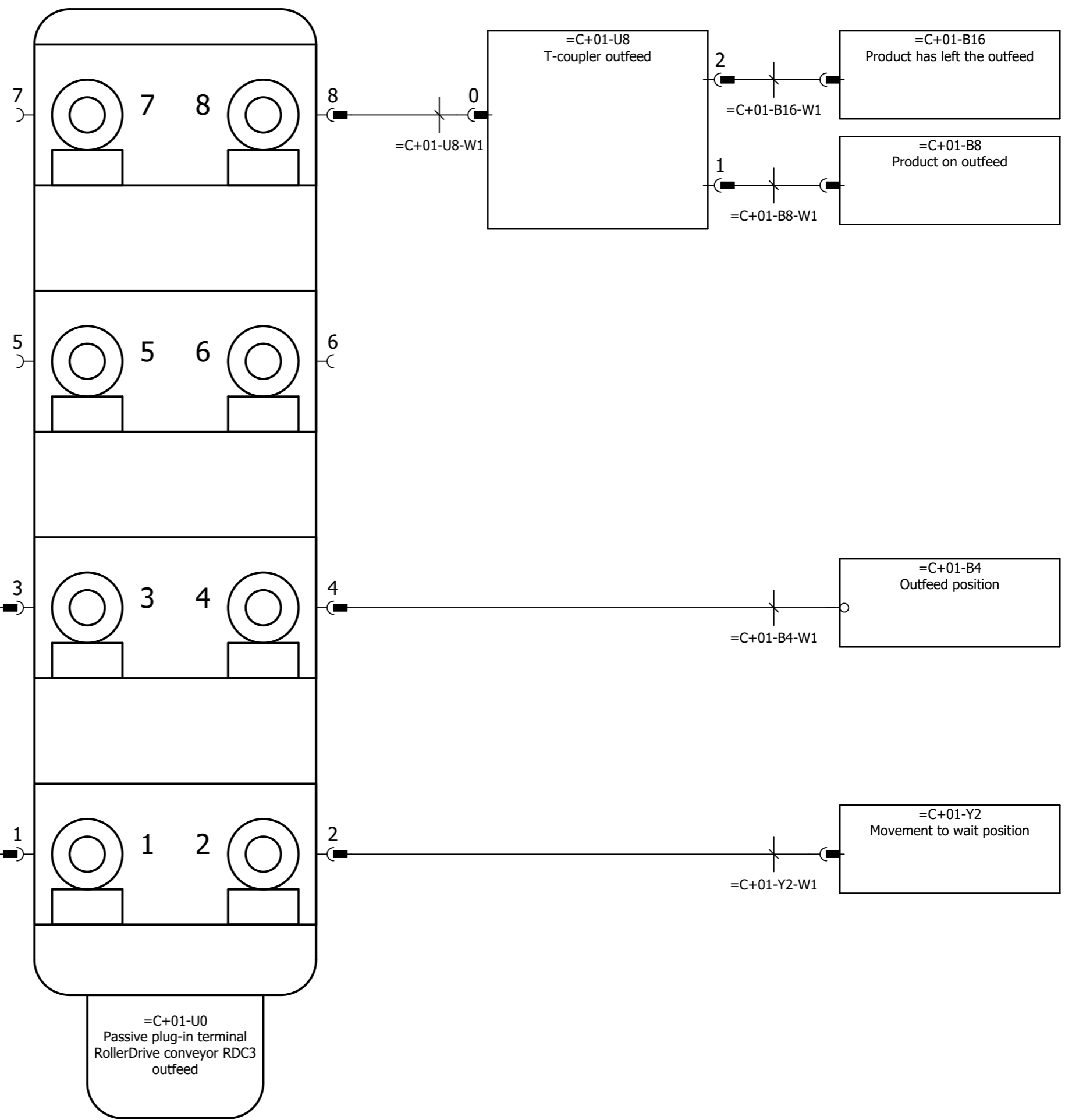

For technical specifications of gearmotor, applied options, machine configuration and other data see specification sheet.

Parts list

Position	Quantity	Article number	Description	Manufacturer	Type number
+01-B1	1	1007850	Proximity Sensor	Festo	SMT-8M-A-PS-24V-E-1-N-M12
+01-B4	1	1007850	Proximity Sensor	Festo	SMT-8M-A-PS-24V-E-1-N-M12
+01-B8	1	1005663	Reflex sensor	Sick	GL6-P4211
+01-B8	1	1002242	Reflector	Sick	C42-2
+01-B8-W1	1	1003307	Prefab cable, PVC, 1 meter, connector M12 male + female M8, 4-pole	Murrelektronik	PVC-OB 4x0,25mm2
+01-B16	1	1005663	Reflex sensor	Sick	GL6-P4211
+01-B16	1	1002242	Reflector	Sick	C42-2
+01-B16-W1	1	1003307	Prefab cable, PVC, 1 meter, connector M12 male + female M8, 4-pole	Murrelektronik	PVC-OB 4x0,25mm2
+01-U0	1	1003309	Passive plug-in terminal, 8-fold, 5-pole, M12	Murrelektronik	Exact12 8xM12 5-p
+01-U8	1	1003313	T-Coupler 5p Male M12 / 2x 4p Female M12, Distribution function	Murrelektronik	T-Coupler5p Male M12 / 2x 4p Female M12
+01-U8-W1	1	1001601	Prefab cable, PVC, 1 meter, connector M12 male 90°+ M12 female 90°, 4-pole	Murrelektronik	PVC-OB 4x0,34mm2
+01-Y2	1		Coil see mechanical part list	Qimarox	
+01-Y2-W1	1	1005959	Prefab cable, PVC, 0,3 meter, connector M12 male + female M8 straight 90°, 3-pole	Murrelektronik	PVC-OB 3x0,25mm2
+01-Y3	1		Coil see mechanical part list	Qimarox	
+01-Y3-W1	1	1005959	Prefab cable, PVC, 0,3 meter, connector M12 male + female M8 straight 90°, 3-pole	Murrelektronik	PVC-OB 3x0,25mm2
+03-M1	1		See specification sheet		
+03-U10	1		See specification sheet		

For technical specifications of gearmotor, applied options, machine configuration and other data see specification sheet.

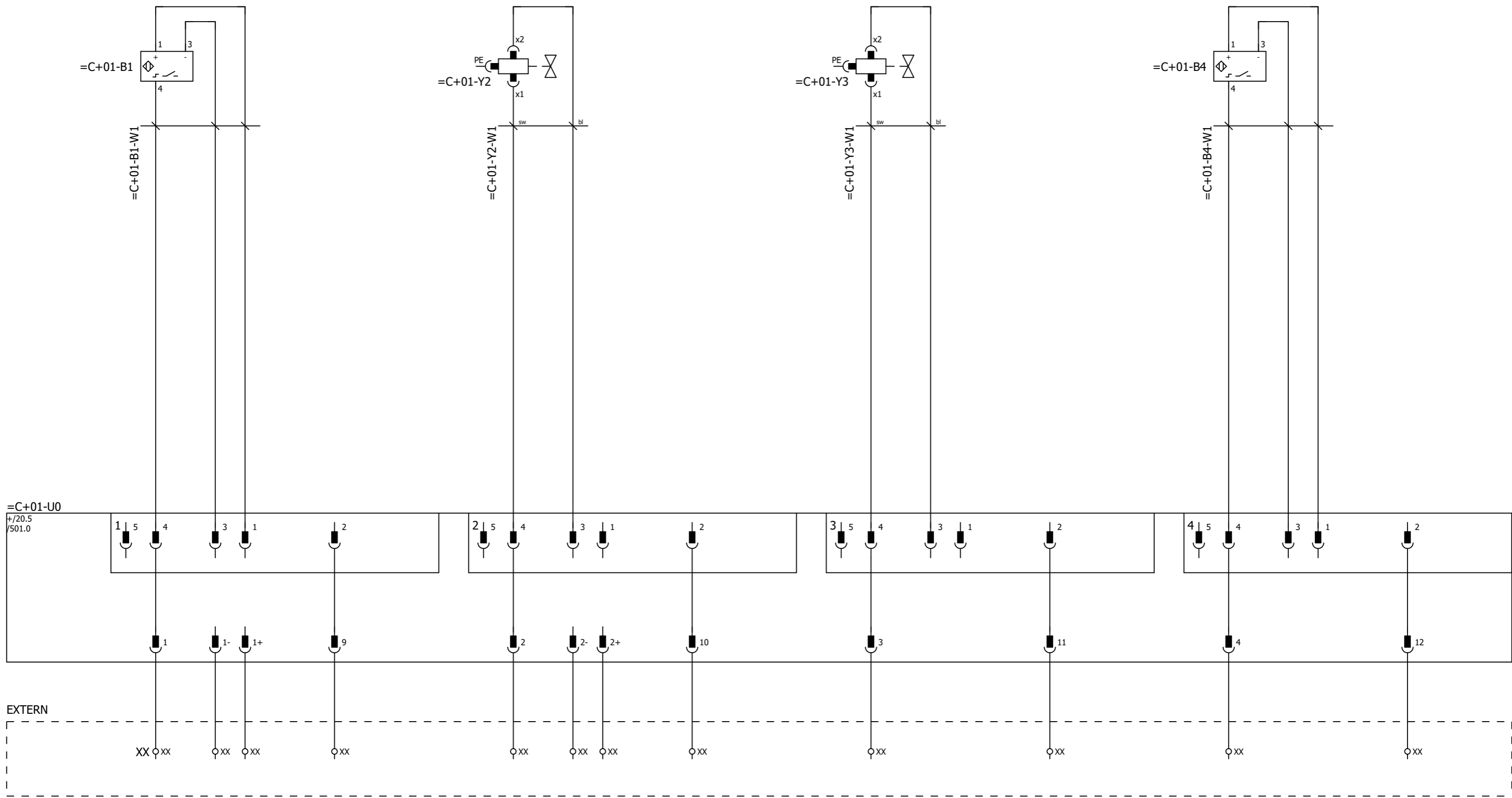

Passive plug-in terminal RollerDrive conveyor RDC3 outfeed

Wait position Spare Movement to wait position Spare Movement to outfeed position Spare Outfeed position Spare



Description of the project
PRmk5 (XL) Sorter conveyors
 Standard

Page description
 Field components

Mounting group	RDC3 outfeed
Mounting location	Detection

Ed.	DSP	=	C
Date	20-12-2021	+	01
Version	v4.5.2		
			Page 500

For technical specifications of gearmotor, applied options, machine configuration and other data see specification sheet.

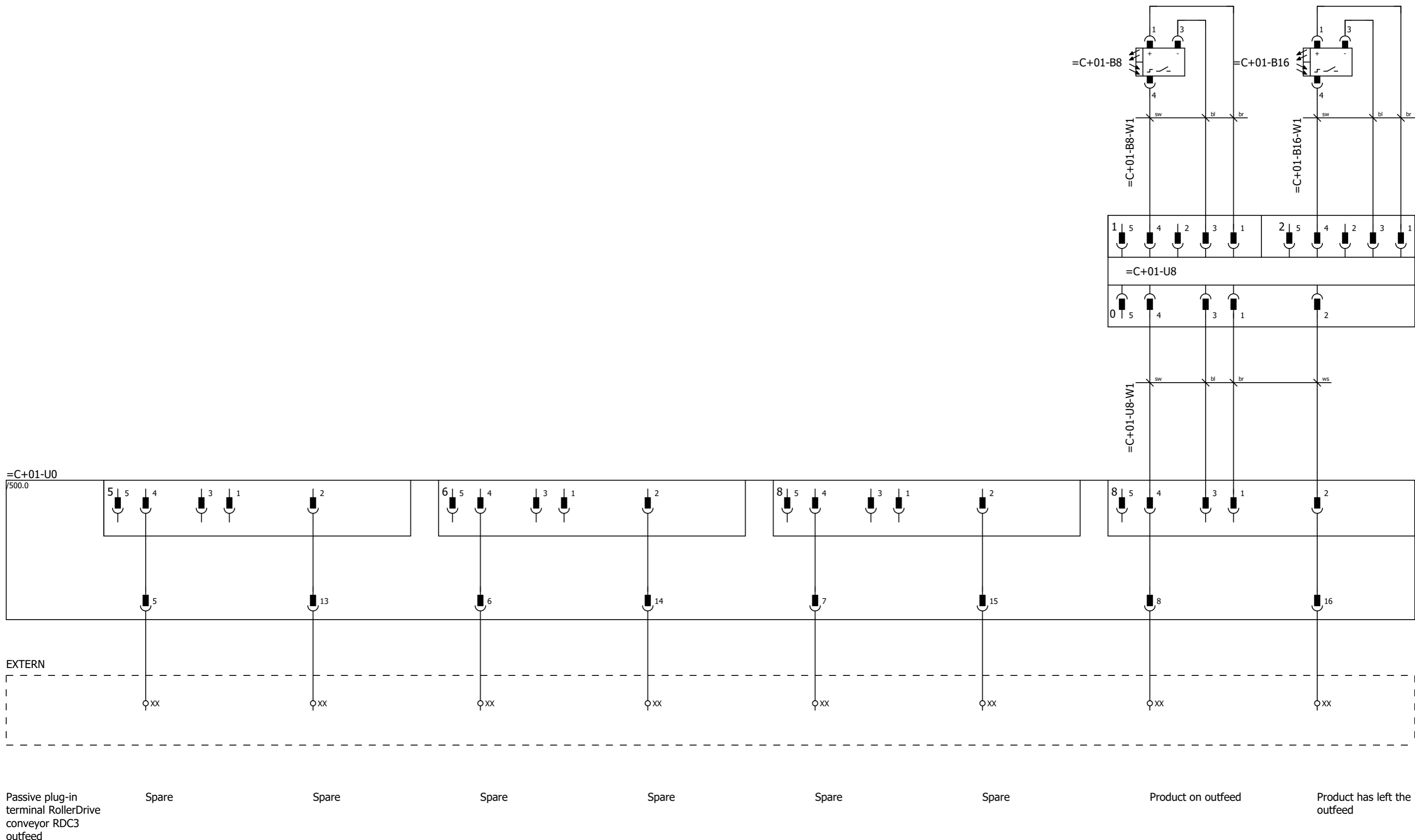

Passive plug-in terminal RollerDrive conveyor RDC3 outfeed

EXTERN

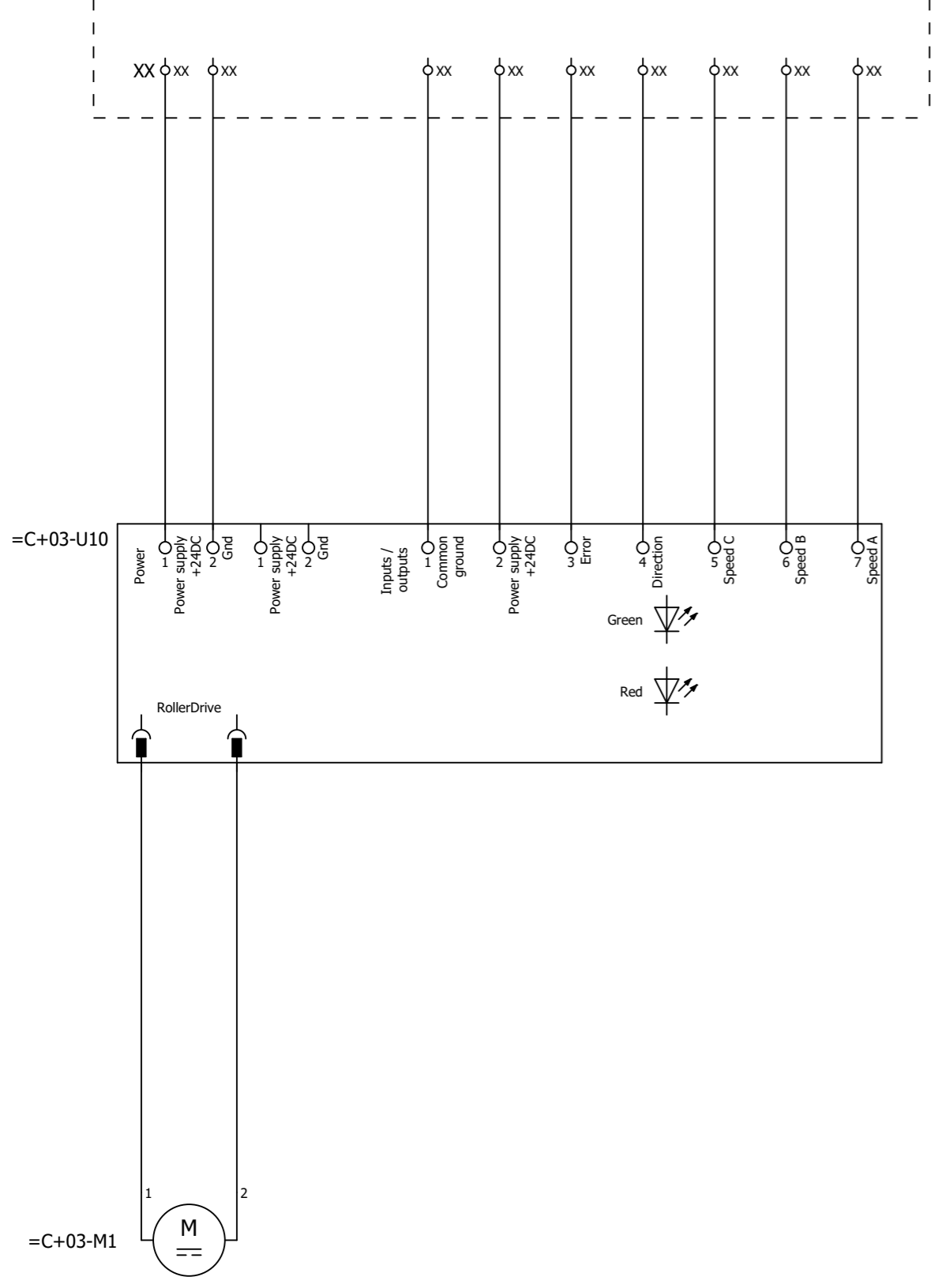

RollerDrive conveyor outfeed

For technical specifications of gearmotor, applied options, machine configuration and other data see specification sheet.



Nobelstraat 43
3846 CE Harderwijk
The Netherlands

Phone: +31 341 - 436700
Fax: +31 341 - 436701
www.qimarox.com
info@qimarox.com

Document name: Electrical drawings PRmk5 (XL) Sorter conveyors v4.5.2
Mounting group: RDC4 infeed
Type: Standard

Power supply: See specification sheet
Control voltage: 24VDC
According to: NEN-EN-IEC 60204-1: 2018

Version number: v4.5.2

Table of contents

Mounting group		Mounting location		Page	Page description
=D	RDC4 infeed			1	Title page
				2	Table of contents
				10	Layout RollerDrive conveyor RDC4 infeed
				20	Overview passive plug-in terminal RDC4 infeed
				2000	Parts list
	+01	Detection		500	Field components
	+01	Detection		501	Field components
	+02	Drive shuttle		150	Gearmotor, 3 fase
	+03	Drive conveyor		100	Rollerdrive, 24VDC

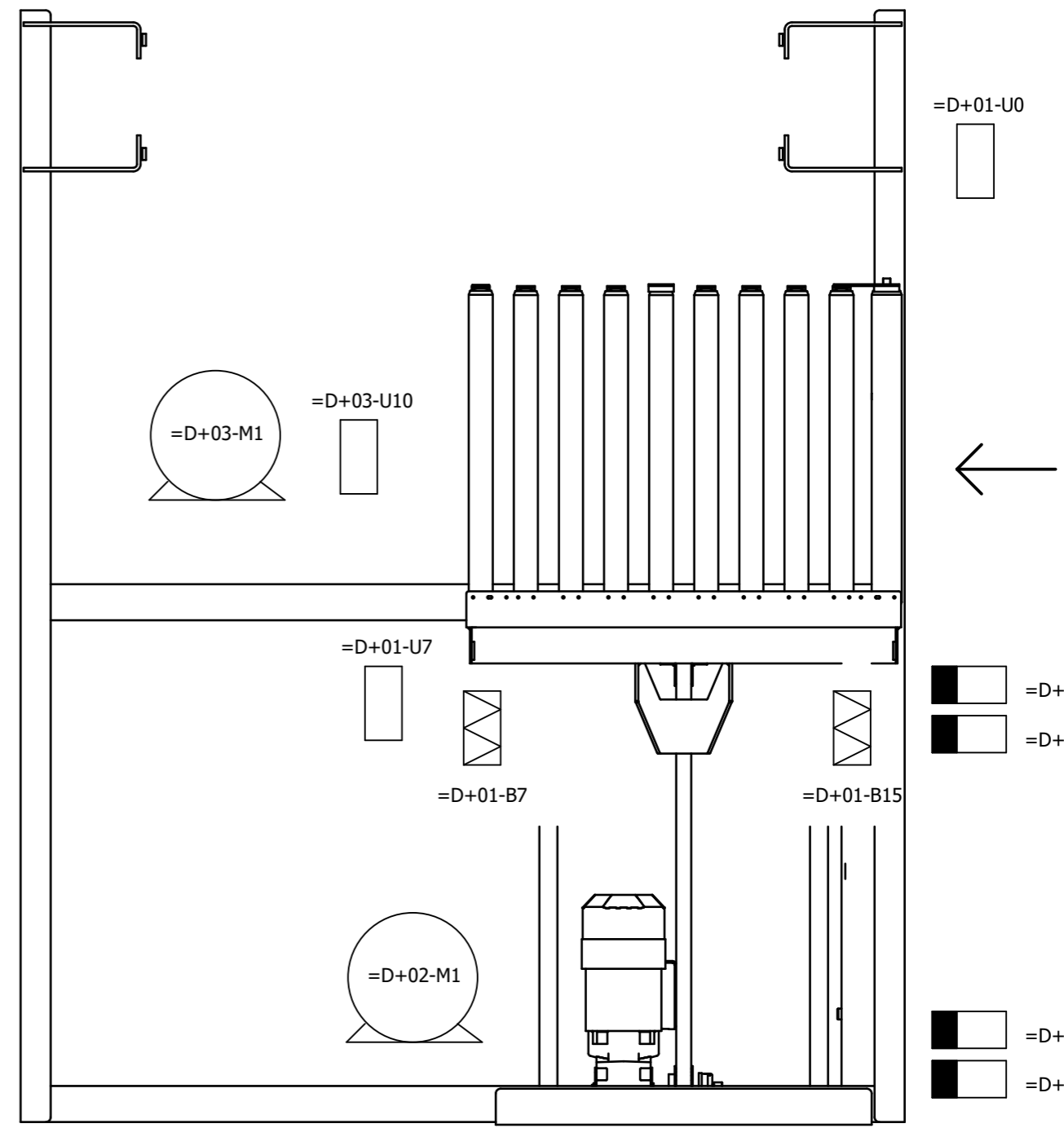
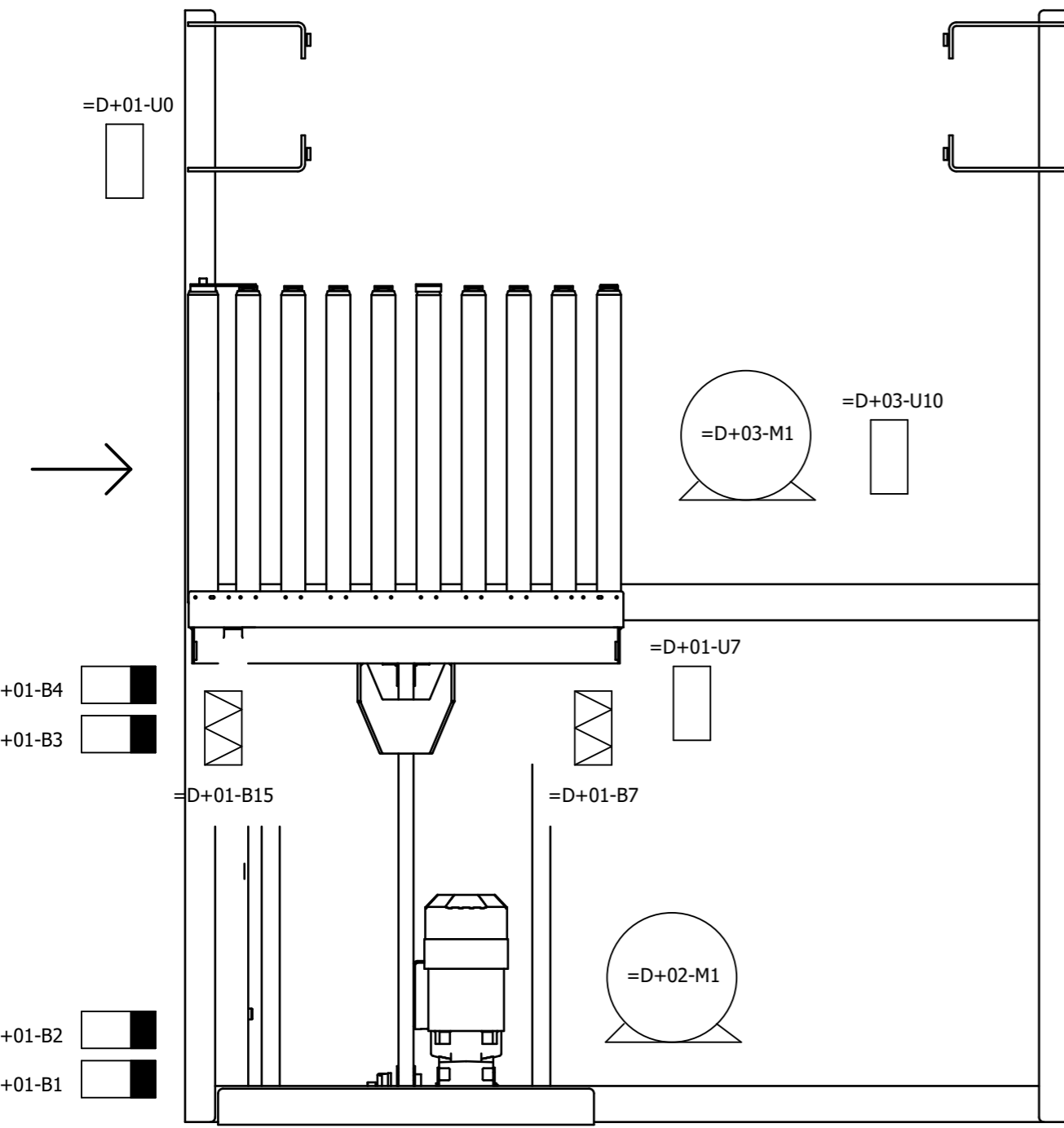

Legend:

- =D+02-M1 Gearmotor shuttle movement
- =D+03-M1 Drive RollerDrive conveyor infeed
- =D+03-U10 Drive control, moveable infeed conveyor

- =D+01-B1 Wait position
- =D+01-B2 Low speed to wait position
- =D+01-B3 Low speed to infeed position
- =D+01-B4 Infeed position
- =D+01-B7 Product on infeed
- =D+01-B15 Product position monitoring

- =D+01-U0 Passive plug-in terminal RollerDrive conveyor RDC4 infeed
- =D+01-U7 T-coupler infeed

For technical specifications of gearmotor, applied options, machine configuration and other data see specification sheet.

Image may differ from reality.

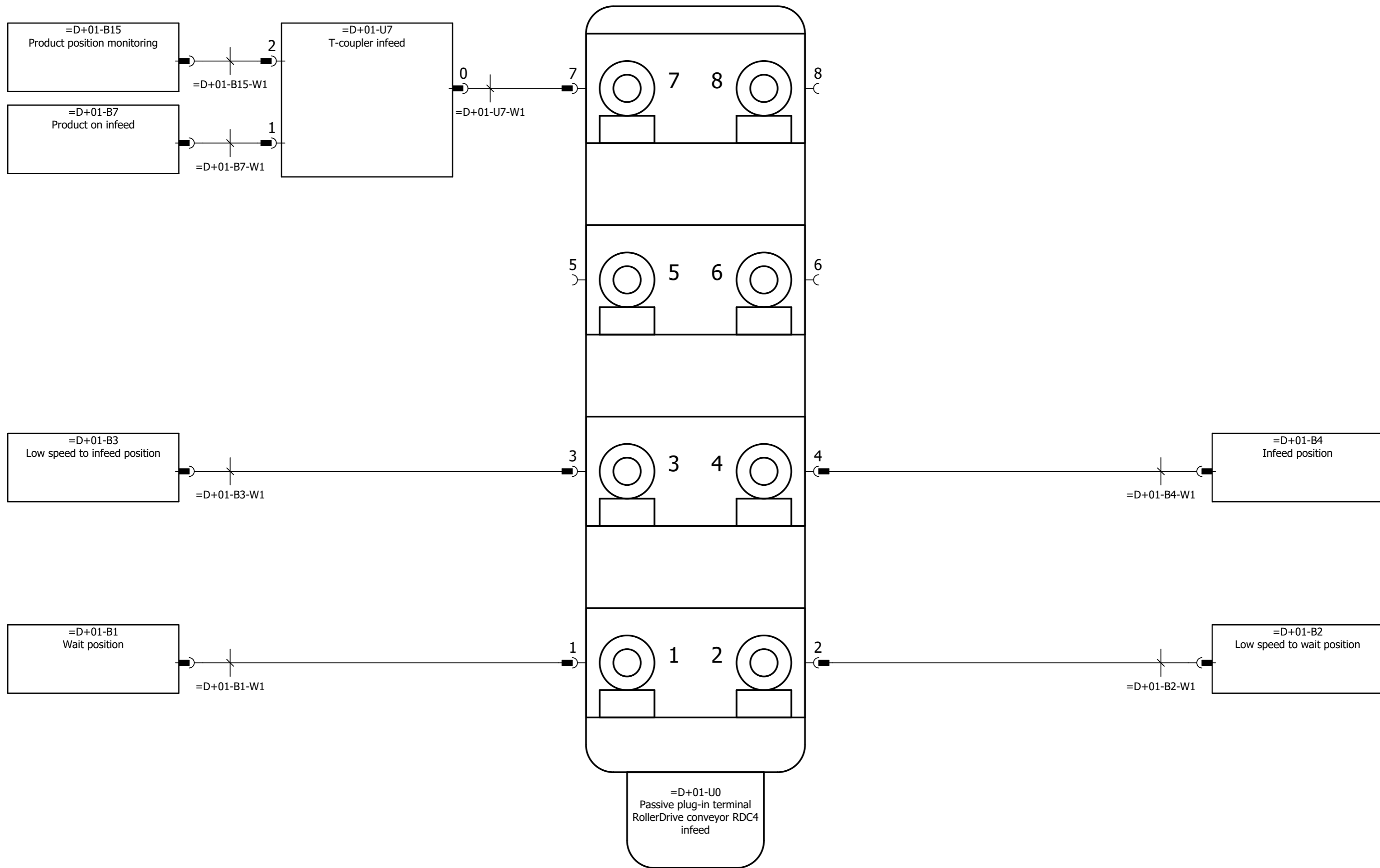

For technical specifications of gearmotor, applied options, machine configuration and other data see specification sheet.

Parts list

Position	Quantity	Article number	Description	Manufacturer	Type number
+01-B1	1	1000932	Inductive proximity sensor	Sick	IME18-08BPSZC0K
+01-B1-W1	1	1001528	Prefab cable, PVC, 2 meter, connector M12 male 90°+ M12 female 90°, 4-pole	Murrelektronik	PVC-OB 4x0,34mm2
+01-B2	1	1000932	Inductive proximity sensor	Sick	IME18-08BPSZC0K
+01-B2-W1	1	1001528	Prefab cable, PVC, 2 meter, connector M12 male 90°+ M12 female 90°, 4-pole	Murrelektronik	PVC-OB 4x0,34mm2
+01-B3	1	1000932	Inductive proximity sensor	Sick	IME18-08BPSZC0K
+01-B3-W1	1	1001601	Prefab cable, PVC, 1 meter, connector M12 male 90°+ M12 female 90°, 4-pole	Murrelektronik	PVC-OB 4x0,34mm2
+01-B4	1	1000932	Inductive proximity sensor	Sick	IME18-08BPSZC0K
+01-B4-W1	1	1001601	Prefab cable, PVC, 1 meter, connector M12 male 90°+ M12 female 90°, 4-pole	Murrelektronik	PVC-OB 4x0,34mm2
+01-B7	1	1005663	Reflex sensor	Sick	GL6-P4211
+01-B7	1	1002242	Reflector	Sick	C42-2
+01-B7-W1	1	1003307	Prefab cable, PVC, 1 meter, connector M12 male + female M8, 4-pole	Murrelektronik	PVC-OB 4x0,25mm2
+01-B15	1	1005663	Reflex sensor	Sick	GL6-P4211
+01-B15	1	1002242	Reflector	Sick	C42-2
+01-B15-W1	1	1003307	Prefab cable, PVC, 1 meter, connector M12 male + female M8, 4-pole	Murrelektronik	PVC-OB 4x0,25mm2
+01-U0	1	1003309	Passive plug-in terminal, 8-fold, 5-pole, M12	Murrelektronik	Exact12 8xM12 5-p
+01-U7	1	1003313	T-Coupler 5p Male M12 / 2x 4p Female M12, Distribution function	Murrelektronik	T-Coupler5p Male M12 / 2x 4p Female M12
+01-U7-W1	1	1003282	Prefab cable, PUR, 2 meter, connector M12 male 90°+ M12 female 90°, 4-pole	Murrelektronik	PUR-OB 4x0,34mm2
+02-M1	1		See specification sheet		
+03-M1	1		See specification sheet		
+03-U10	1		See specification sheet		

For technical specifications of gearmotor, applied options, machine configuration and other data see specification sheet.

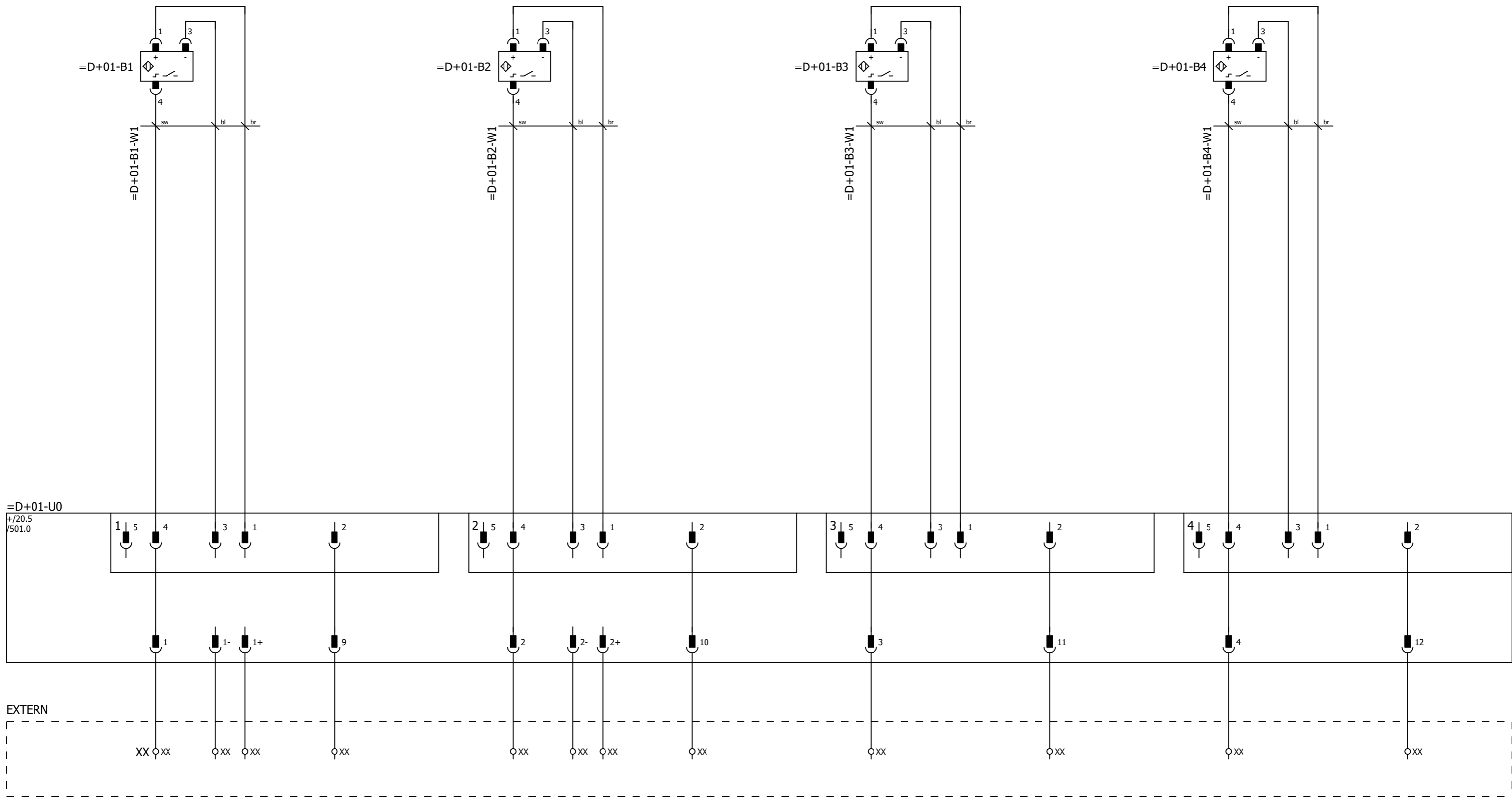

Passive plug-in terminal RollerDrive conveyor RDC4 infeed

Wait position Spare Low speed to wait position Spare Low speed to infeed position Spare Infeed position Spare

For technical specifications of gearmotor, applied options, machine configuration and other data see specification sheet.

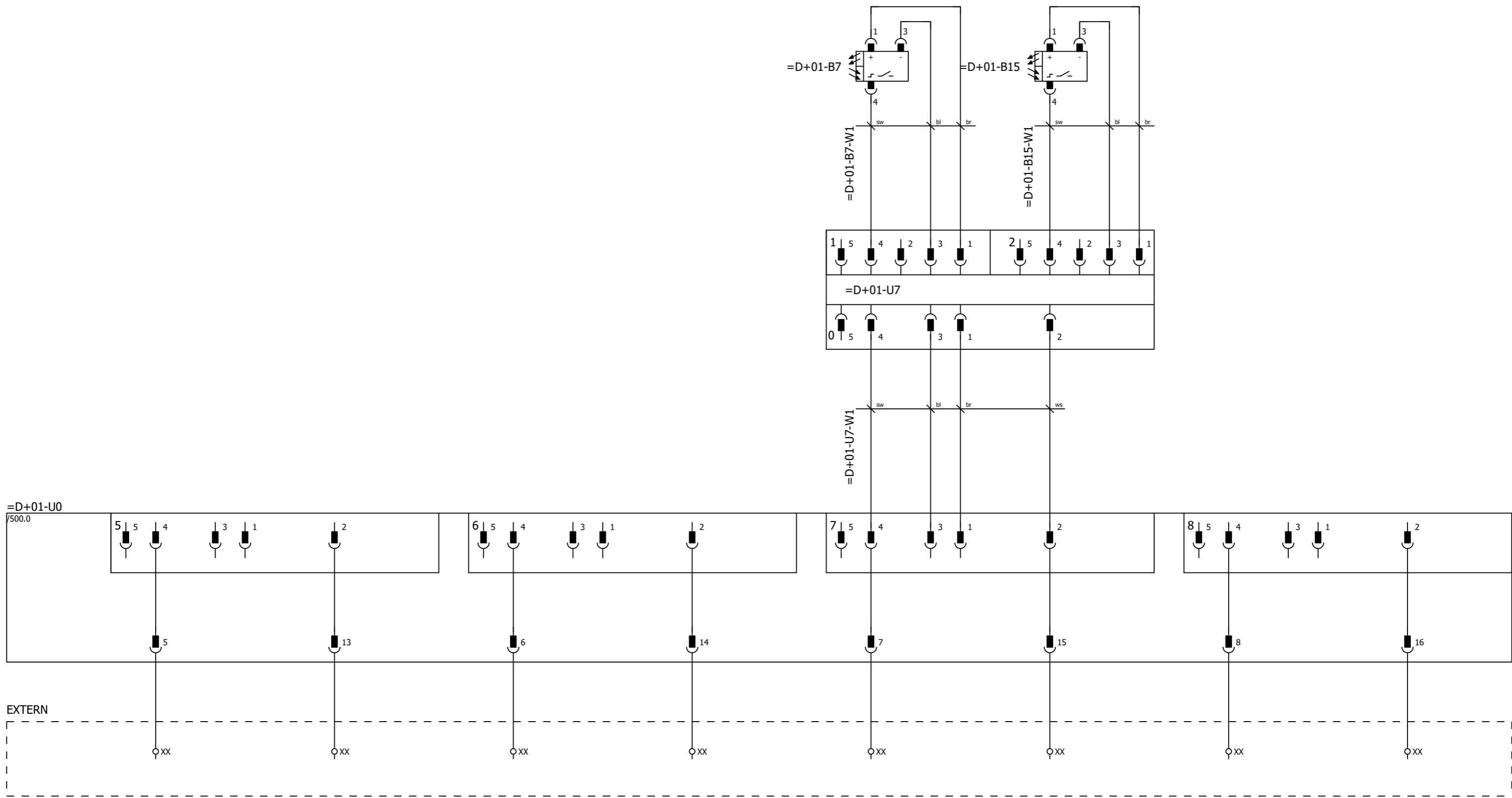

Passive plug-in terminal RollerDrive conveyor RDC4 infeed Spare Spare Spare Spare Product on infeed Product position monitoring Spare Spare

EXTERN

Alternative

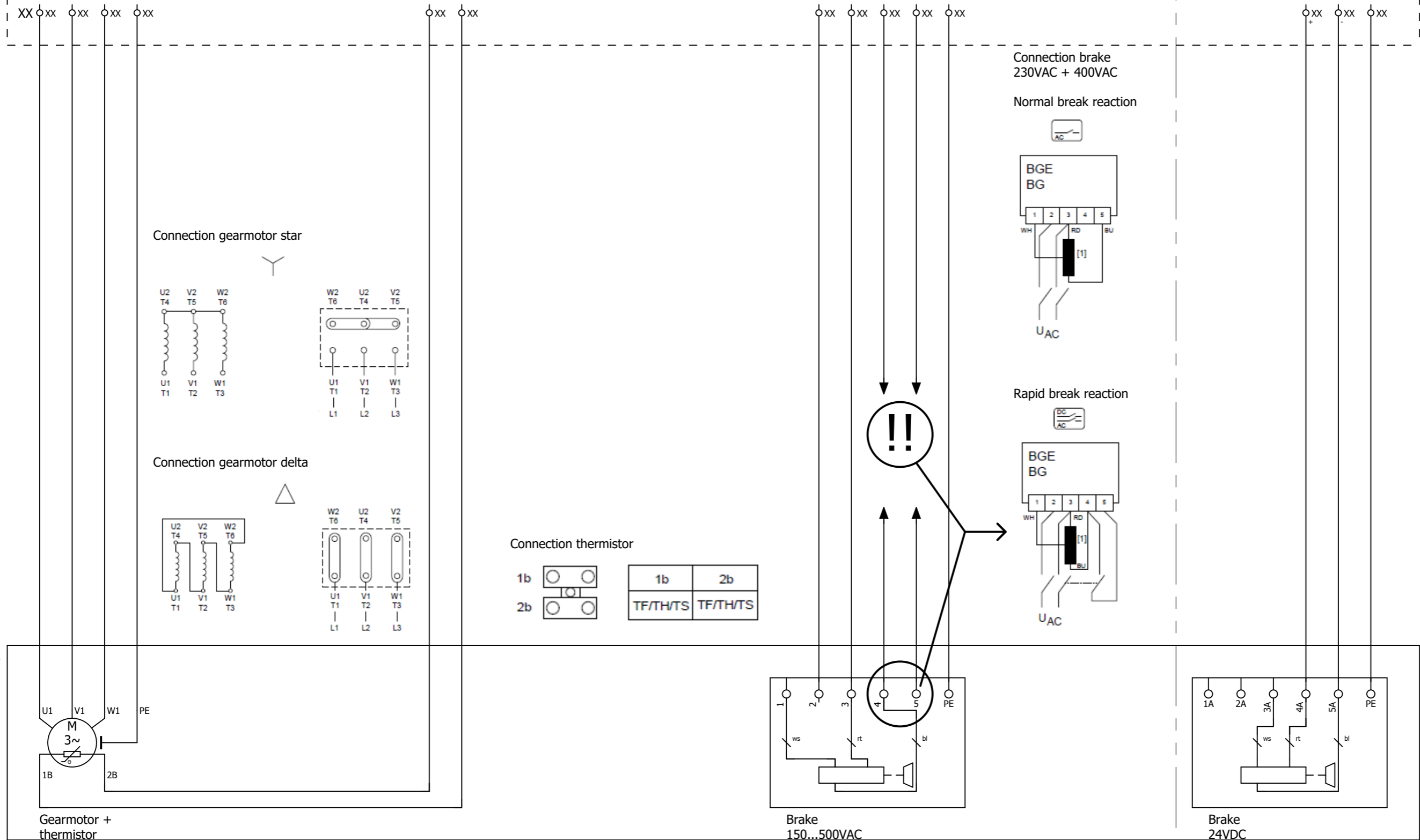

=D+02-M1

Gearmotor + thermistor

Brake 150...500VAC

Brake 24VDC

Gearmotor shuttle movement

For technical specifications of gearmotor, applied options, machine configuration and other data see specification sheet.

EXTERN

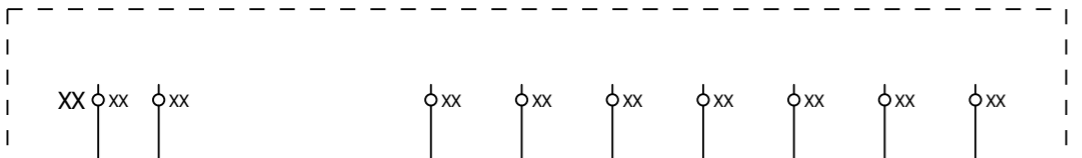

=D+03-U10

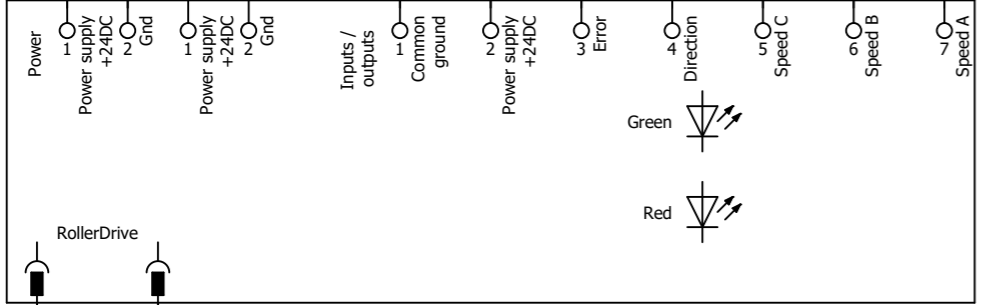

=D+03-M1

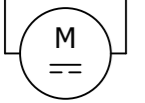

RollerDrive conveyor infeed

For technical specifications of gearmotor, applied options, machine configuration and other data see specification sheet.



Nobelstraat 43
3846 CE Harderwijk
The Netherlands

Phone: +31 341 - 436700
Fax: +31 341 - 436701
www.qimarox.com
info@qimarox.com

Document name: Electrical drawings PRmk5 (XL) Sorter conveyors v4.5.2
Mounting group: RDC4 outfeed
Type: Standard

Power supply: See specification sheet
Control voltage: 24VDC
According to: NEN-EN-IEC 60204-1: 2018

Version number: v4.5.2

Table of contents

Mounting group		Mounting location		Page	Page description
=E	RDC4 outfeed			1	Title page
				2	Table of contents
				10	Layout RollerDrive conveyor RDC4 outfeed
				20	Overview passive plug-in terminal RDC4 outfeed
				2000	Parts list
		+01	Detection	500	Field components
		+01	Detection	501	Field components
		+02	Drive shuttle	150	Gearmotor, 3 fase
		+03	Drive conveyor	100	Rollerdrive, 24VDC

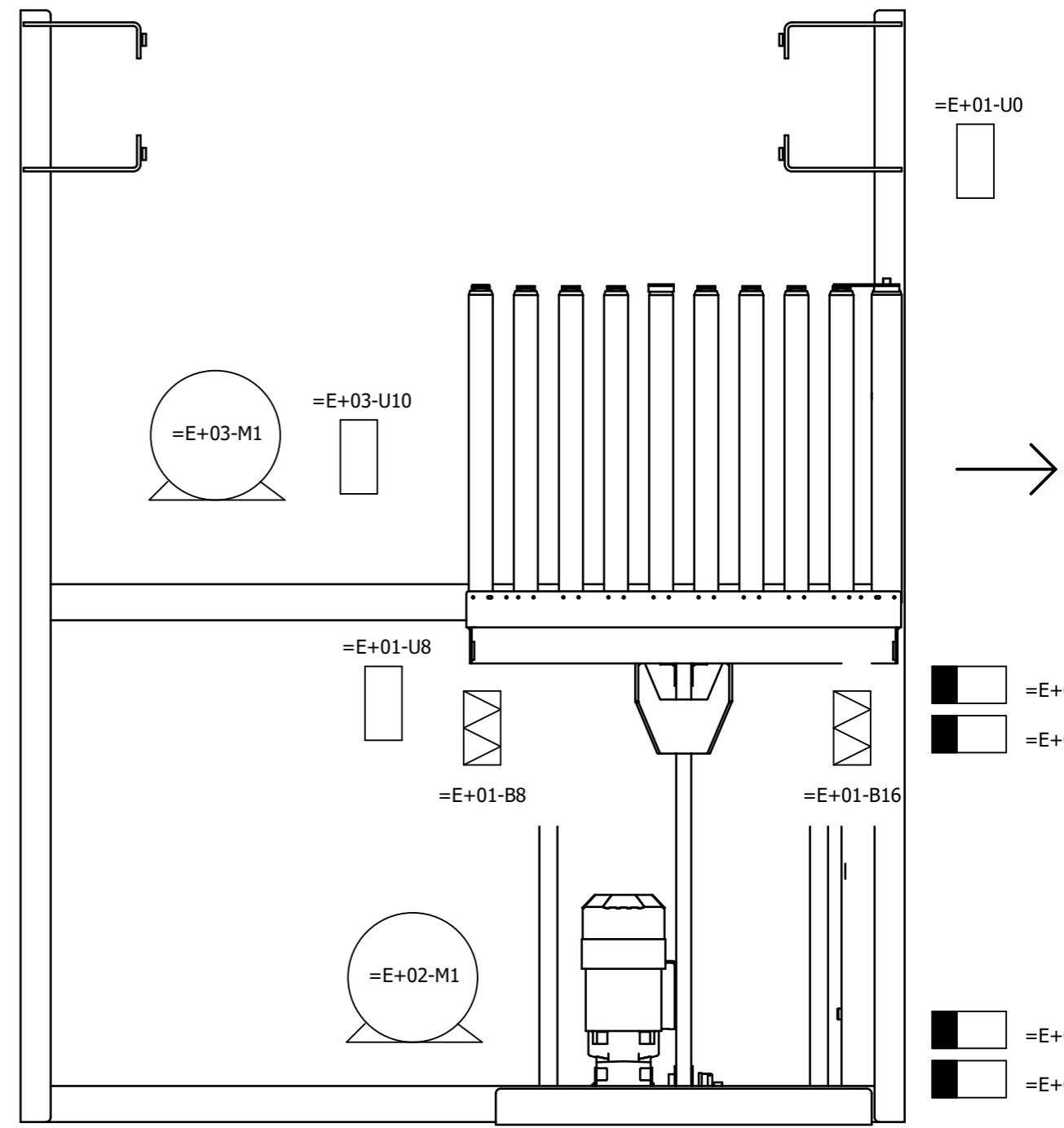
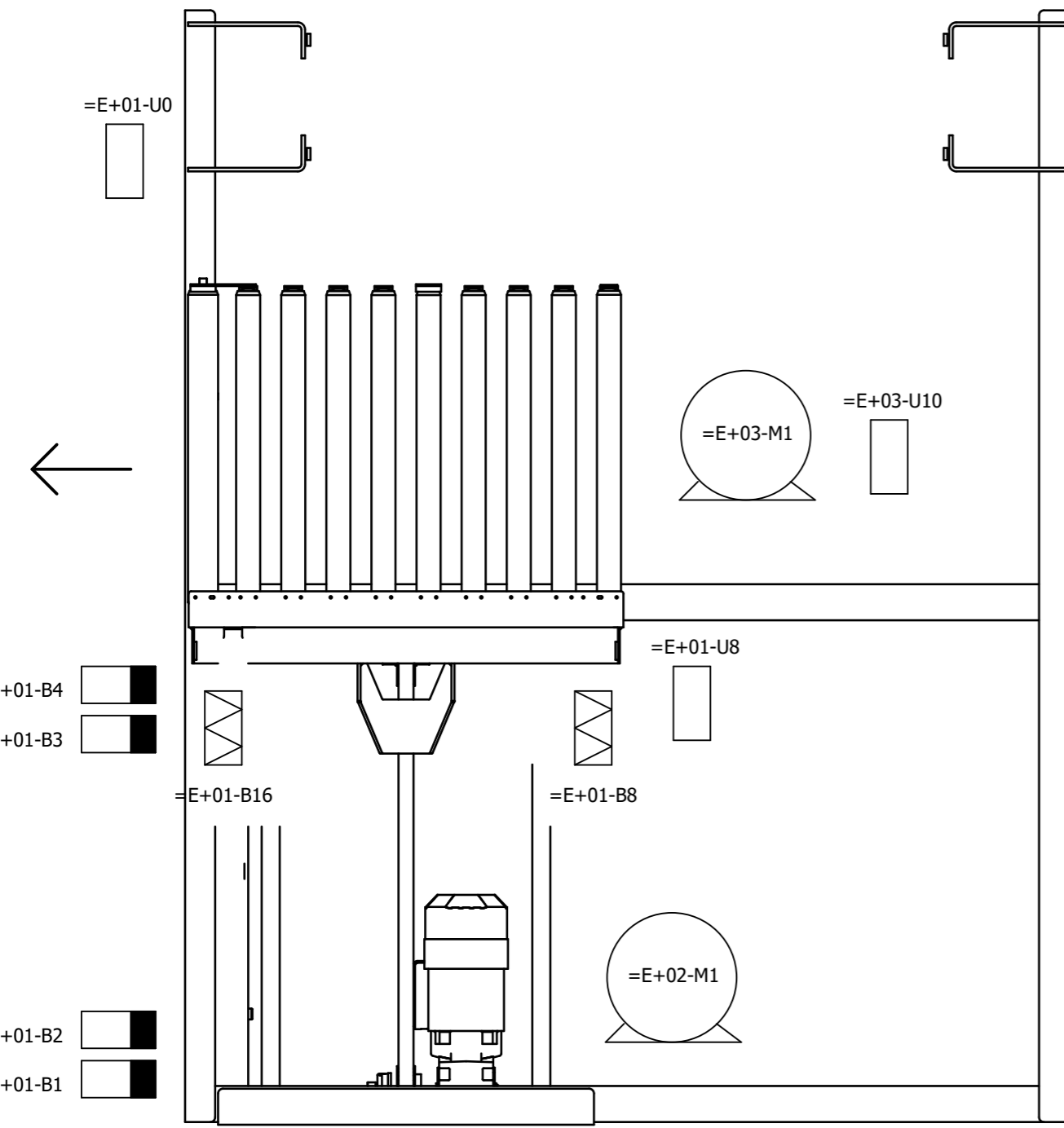

Legend:

- =E+02-M1 Gearmotor shuttle movement
- =E+03-M1 Drive RollerDrive conveyor outfeed
- =E+03-U10 Drive control, moveable outfeed conveyor

- =E+01-B1 Wait position
- =E+01-B2 Low speed to wait position
- =E+01-B3 Low speed to outfeed position
- =E+01-B4 Outfeed position
- =E+01-B8 Product on outfeed
- =E+01-B16 Product has left the outfeed

- =E+01-U0 Passive plug-in terminal RollerDrive conveyor RDC4 outfeed
- =E+01-U8 T-coupler outfeed

For technical specifications of gearmotor, applied options, machine configuration and other data see specification sheet.

Image may differ from reality.

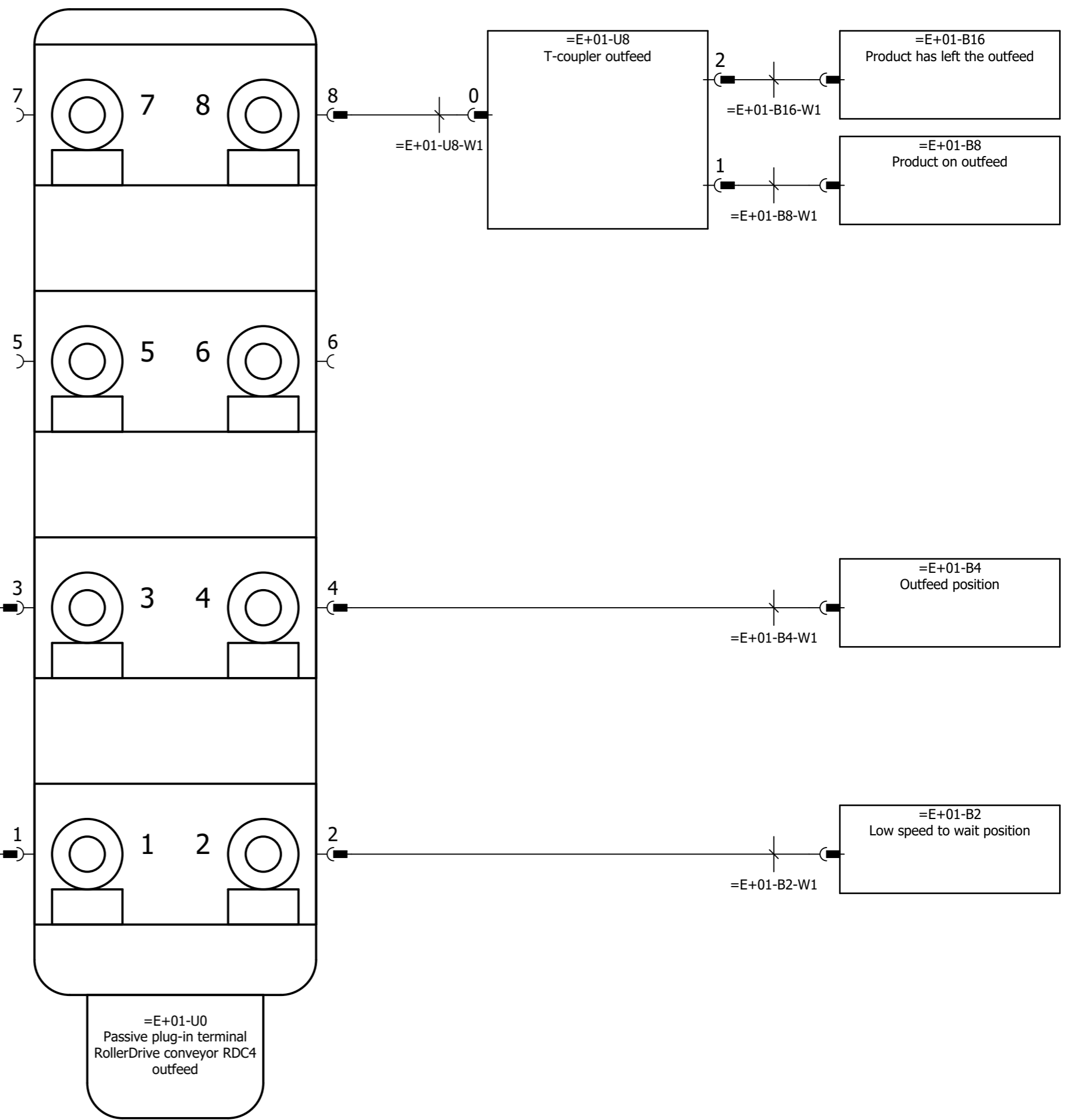

For technical specifications of gearmotor, applied options, machine configuration and other data see specification sheet.

Parts list

Position	Quantity	Article number	Description	Manufacturer	Type number
+01-B1	1	1000932	Inductive proximity sensor	Sick	IME18-08BPSZC0K
+01-B1-W1	1	1001528	Prefab cable, PVC, 2 meter, connector M12 male 90°+ M12 female 90°, 4-pole	Murrelektronik	PVC-OB 4x0,34mm2
+01-B2	1	1000932	Inductive proximity sensor	Sick	IME18-08BPSZC0K
+01-B2-W1	1	1001528	Prefab cable, PVC, 2 meter, connector M12 male 90°+ M12 female 90°, 4-pole	Murrelektronik	PVC-OB 4x0,34mm2
+01-B3	1	1000932	Inductive proximity sensor	Sick	IME18-08BPSZC0K
+01-B3-W1	1	1001601	Prefab cable, PVC, 1 meter, connector M12 male 90°+ M12 female 90°, 4-pole	Murrelektronik	PVC-OB 4x0,34mm2
+01-B4	1	1000932	Inductive proximity sensor	Sick	IME18-08BPSZC0K
+01-B4-W1	1	1001601	Prefab cable, PVC, 1 meter, connector M12 male 90°+ M12 female 90°, 4-pole	Murrelektronik	PVC-OB 4x0,34mm2
+01-B8	1	1005663	Reflex sensor	Sick	GL6-P4211
+01-B8	1	1002242	Reflector	Sick	C42-2
+01-B8-W1	1	1003307	Prefab cable, PVC, 1 meter, connector M12 male + female M8, 4-pole	Murrelektronik	PVC-OB 4x0,25mm2
+01-B16	1	1005663	Reflex sensor	Sick	GL6-P4211
+01-B16	1	1002242	Reflector	Sick	C42-2
+01-B16-W1	1	1003307	Prefab cable, PVC, 1 meter, connector M12 male + female M8, 4-pole	Murrelektronik	PVC-OB 4x0,25mm2
+01-U0	1	1003309	Passive plug-in terminal, 8-fold, 5-pole, M12	Murrelektronik	Exact12 8xM12 5-p
+01-U8	1	1003313	T-Coupler 5p Male M12 / 2x 4p Female M12, Distribution function	Murrelektronik	T-Coupler5p Male M12 / 2x 4p Female M12
+01-U8-W1	1	1003282	Prefab cable, PUR, 2 meter, connector M12 male 90°+ M12 female 90°, 4-pole	Murrelektronik	PUR-OB 4x0,34mm2
+02-M1	1		See specification sheet		
+03-M1	1		See specification sheet		
+03-U10	1		See specification sheet		

For technical specifications of gearmotor, applied options, machine configuration and other data see specification sheet.

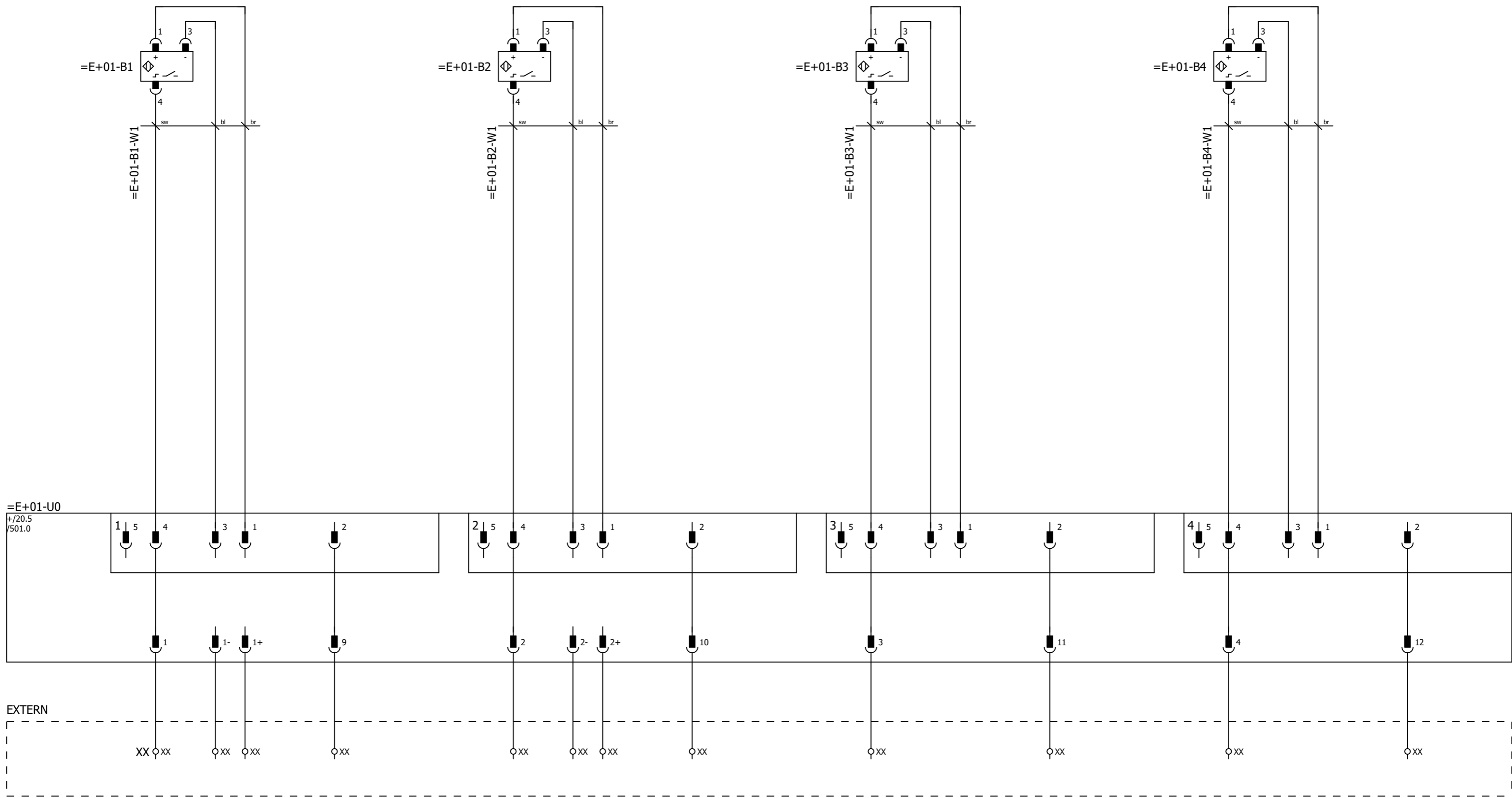

Passive plug-in terminal RollerDrive conveyor RDC4 outfeed

Wait position Spare Low speed to wait position Spare Low speed to outfeed position Spare Outfeed position Spare



Description of the project
PRmk5 (XL) Sorter conveyors
Standard

Page description
Field components

Mounting group	RDC4 outfeed
Mounting location	Detection

Ed.	DSP	=	E
Date	20-12-2021	+	01
Version	v4.5.2		
			Page 500

For technical specifications of gearmotor, applied options, machine configuration and other data see specification sheet.

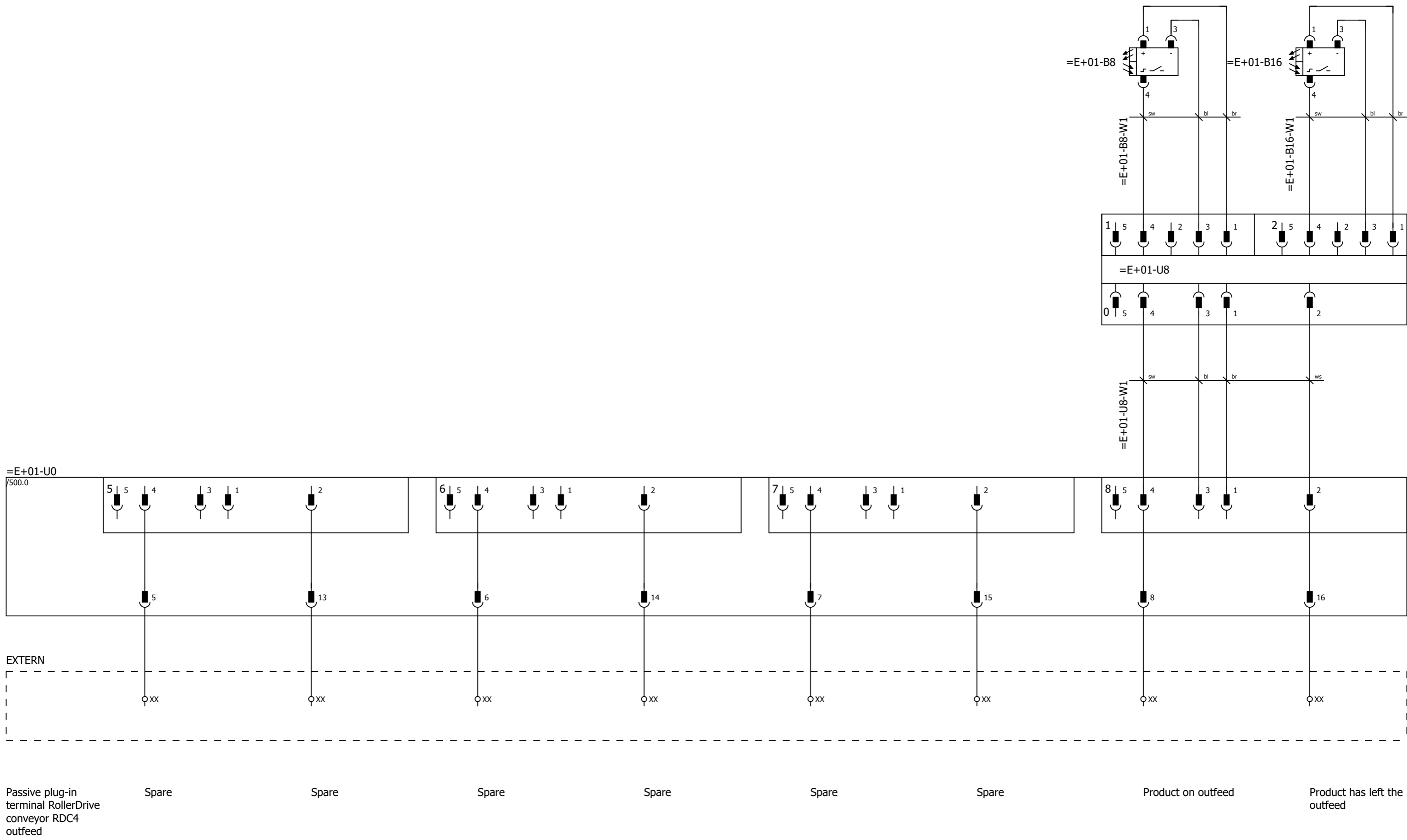

Passive plug-in terminal RollerDrive conveyor RDC4 outfeed

Spare Spare Spare Spare Spare Spare Product on outfeed Product has left the outfeed

EXTERN

Alternative

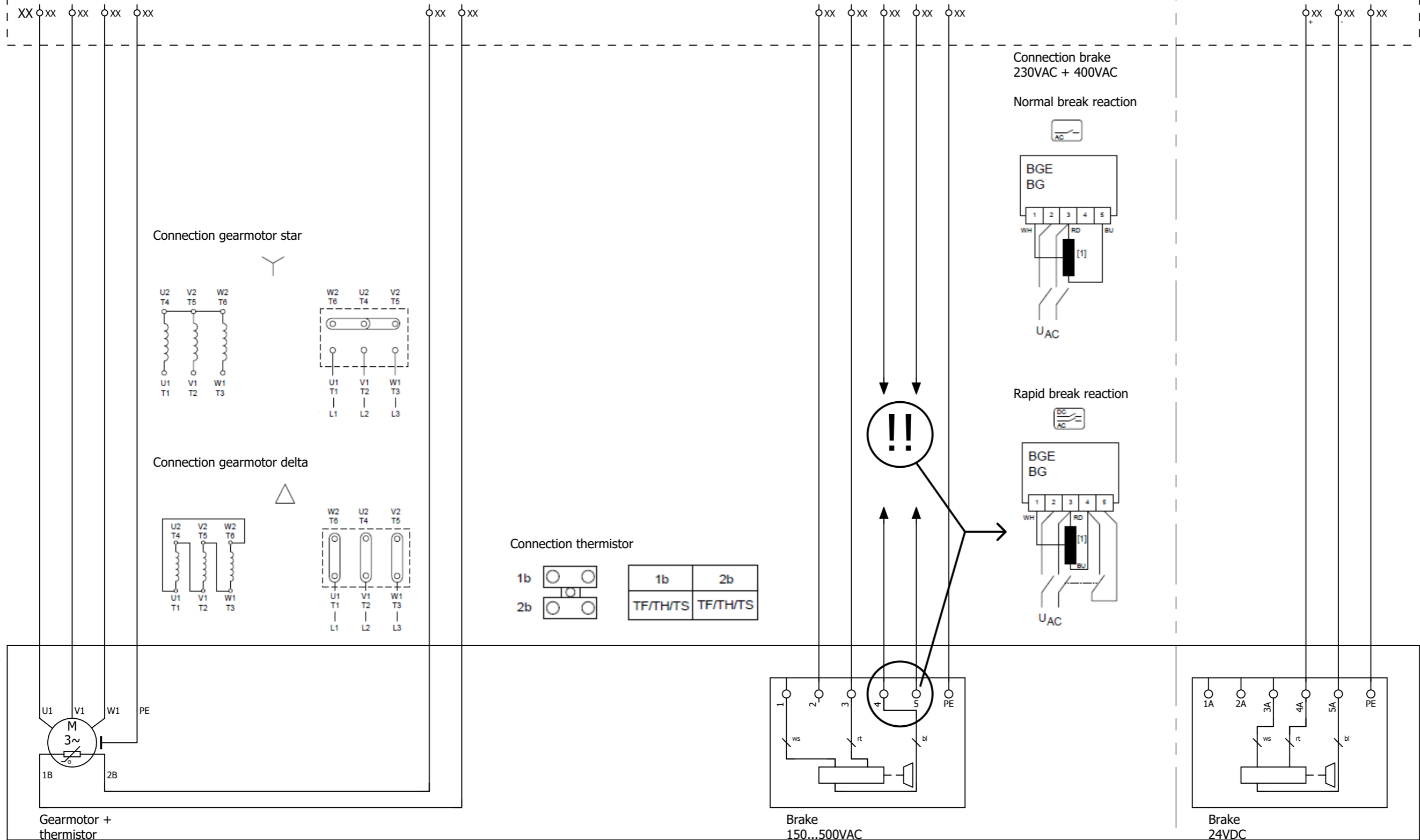

=E+02-M1

Gearmotor shuttle movement

For technical specifications of gearmotor, applied options, machine configuration and other data see specification sheet.

0 1 2 3 4 5 6 7 8 9

EXTERN

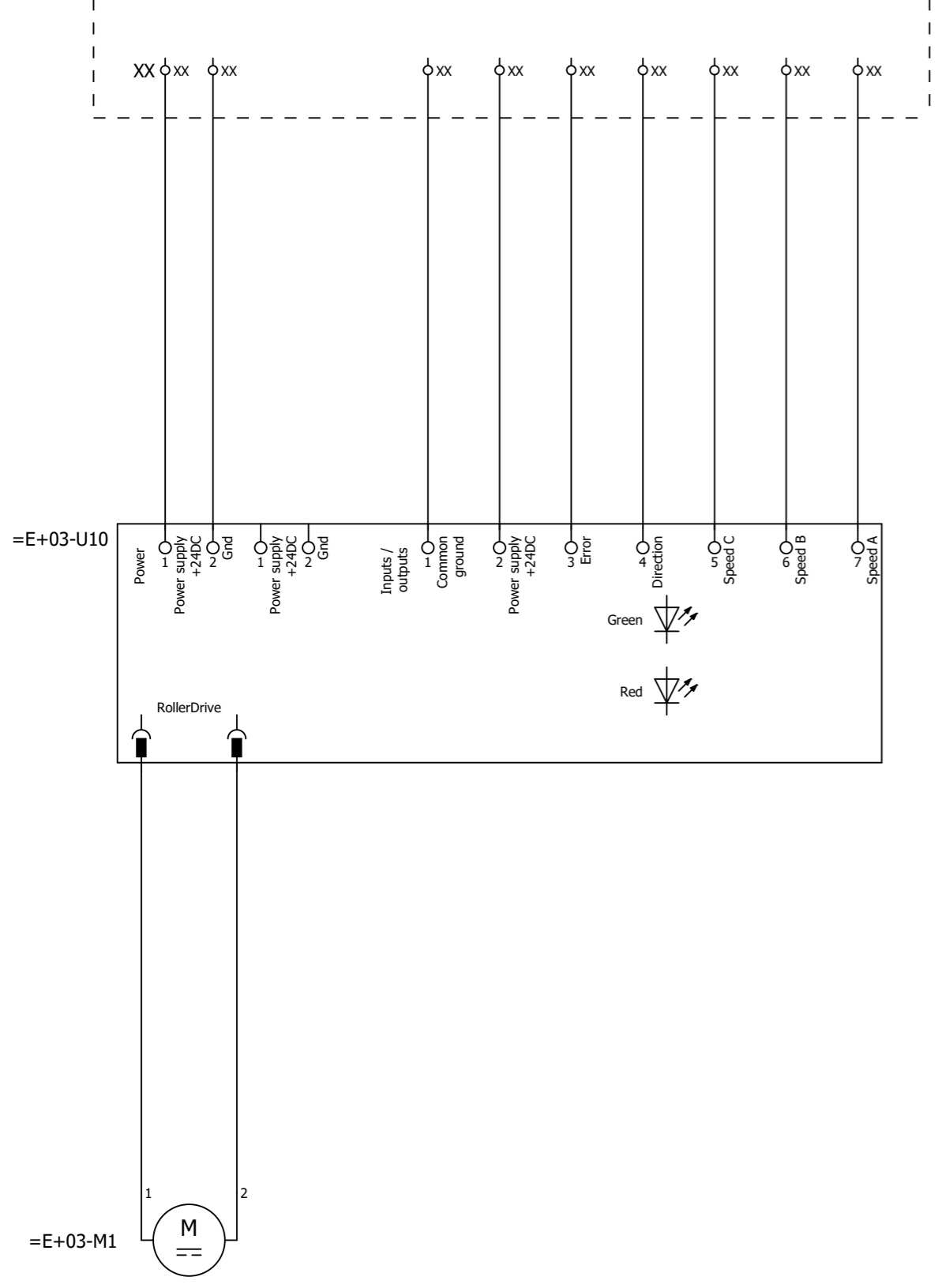

RollerDrive conveyor outfeed

For technical specifications of gearmotor, applied options, machine configuration and other data see specification sheet.



Nobelstraat 43
3846 CE Harderwijk
The Netherlands

Phone: +31 341 - 436700
Fax: +31 341 - 436701
www.qimarox.com
info@qimarox.com

Document name: Electrical drawings PRmk5 (XL) Sorter conveyors v4.5.2
Mounting group: MBC3 infeed
Type: Standard

Power supply: See specification sheet
Control voltage: 24VDC
According to: NEN-EN-IEC 60204-1: 2018

Version number: v4.5.2

Table of contents

Mounting group		Mounting location		Page	Page description
=F	MBC3 infeed			1	Title page
				2	Table of contents
				10	Layout Multi belt conveyor MBC3 infeed
				20	Overview passive plug-in terminal MBC3 infeed
				2000	Parts list
		+01	Detection	500	Field components
		+01	Detection	501	Field components
		+03	Drive conveyor	150	Gearmotor, 3 fase

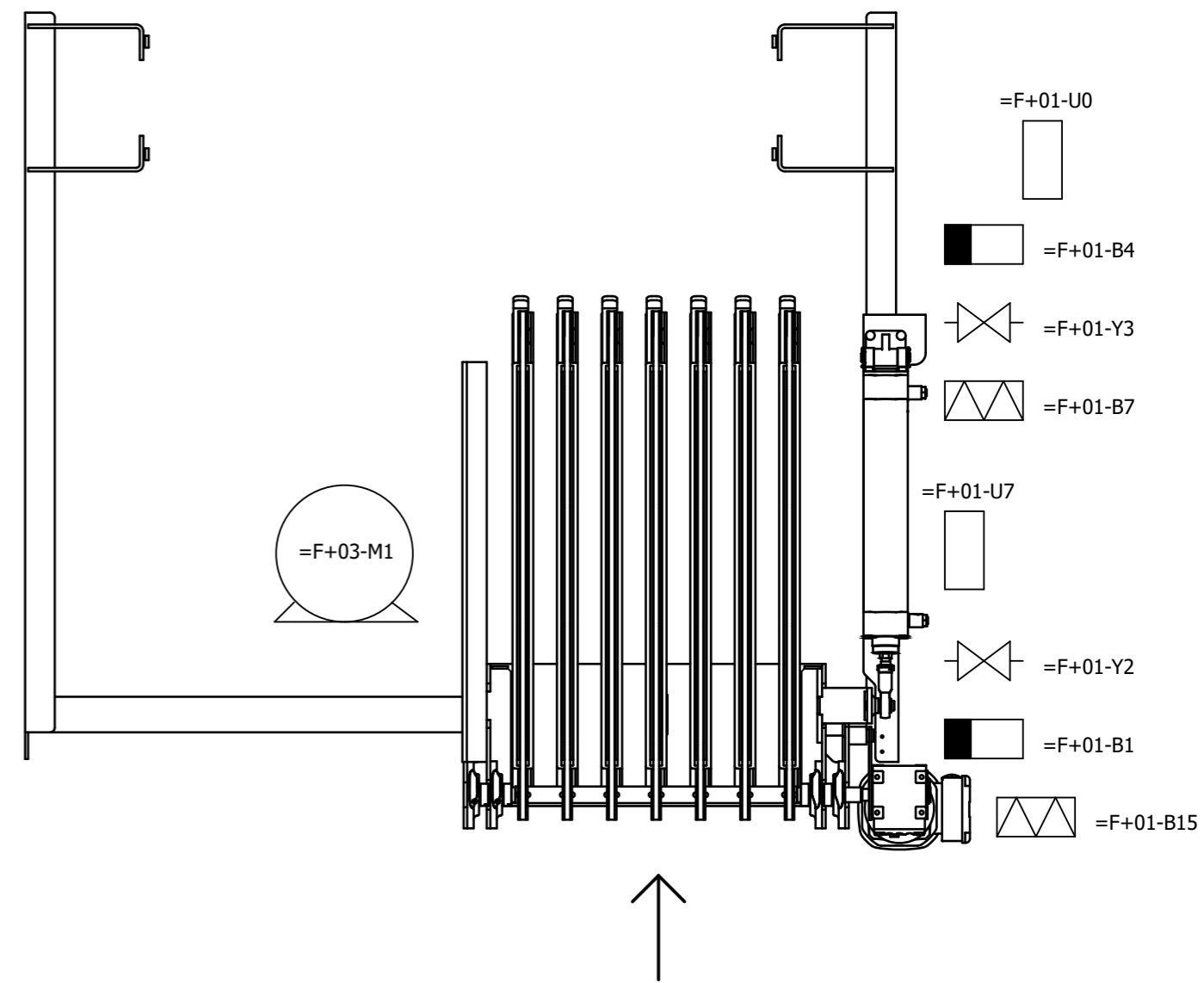
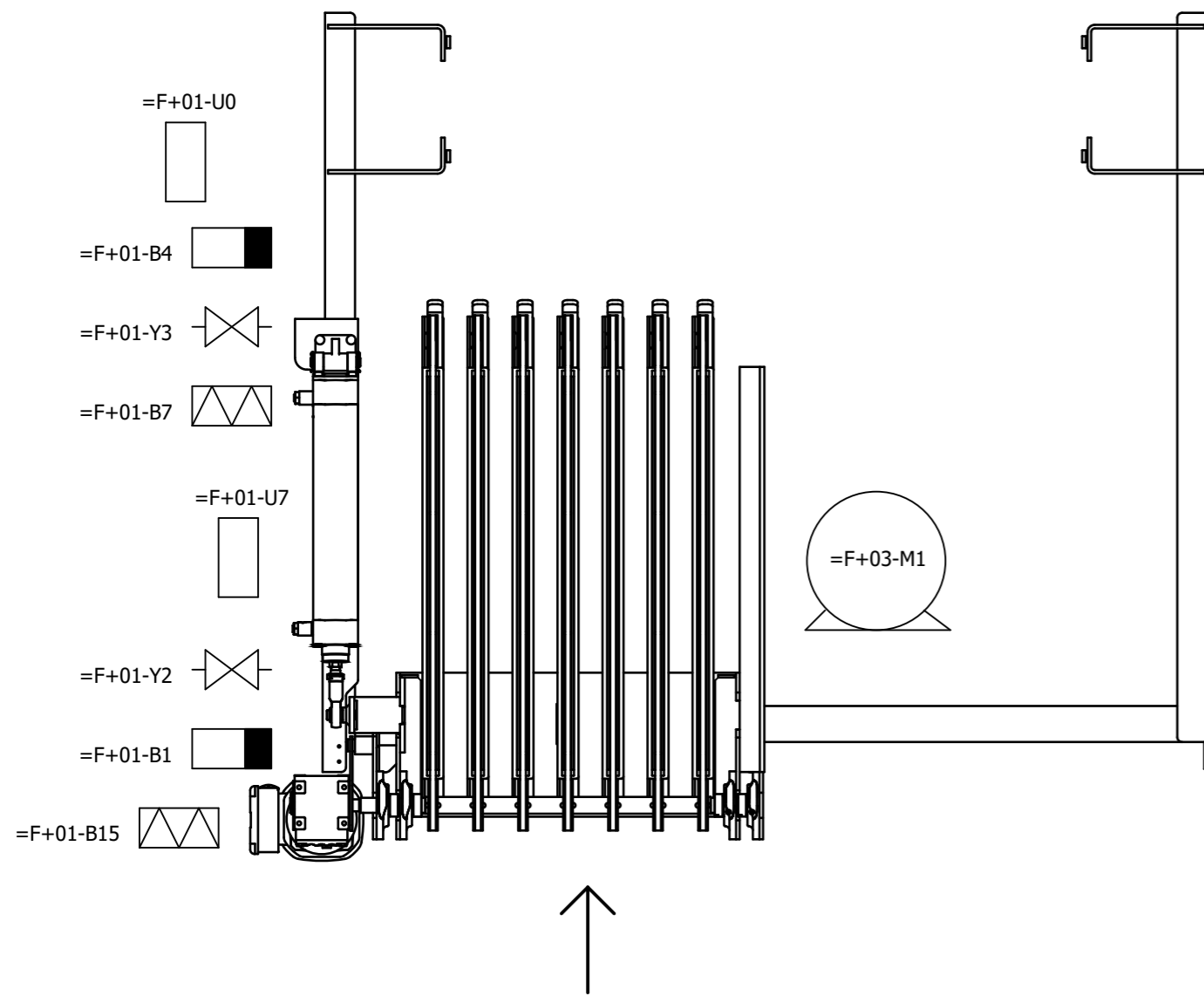

Legend:

- =F+03-M1 Gearmotor conveyor infeed

- =F+01-B1 Wait position
- =F+01-Y2 Movement to wait position
- =F+01-Y3 Movement to infeed position
- =F+01-B4 Infeed position
- =F+01-B7 Product on infeed
- =F+01-B15 Product position monitoring

- =F+01-U0 Passive plug-in terminal Multi belt conveyor MBC3 infeed
- =F+01-U7 T-coupler infeed

For technical specifications of gearmotor, applied options, machine configuration and other data see specification sheet.

Image may differ from reality.

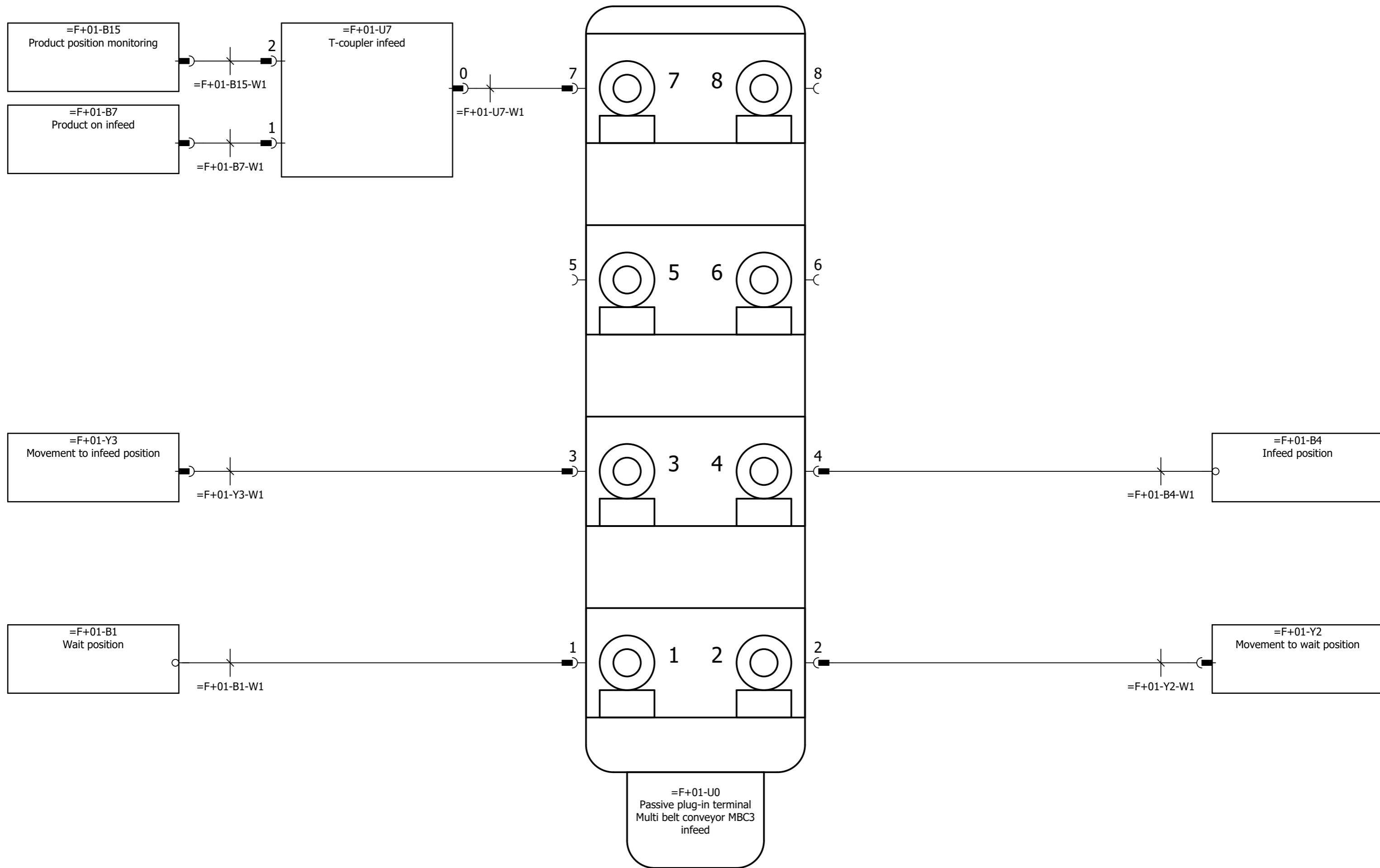

For technical specifications of gearmotor, applied options, machine configuration and other data see specification sheet.

Parts list

Position	Quantity	Article number	Description	Manufacturer	Type number
+01-B1	1	1007850	Proximity Sensor	Festo	SMT-8M-A-PS-24V-E-1-N-M12
+01-B4	1	1007850	Proximity Sensor	Festo	SMT-8M-A-PS-24V-E-1-N-M12
+01-B7	1	1005663	Reflex sensor	Sick	GL6-P4211
+01-B7	1	1002242	Reflector	Sick	C42-2
+01-B7	1	AE0036129	Reflective tape	Sick	REF-PLUS-R50
+01-B7	1	1003365	Proximity sensor	Sick	GTB6-P4211
+01-B7-W1	1	1003307	Prefab cable, PVC, 1 meter, connector M12 male + female M8, 4-pole	Murrelektronik	PVC-OB 4x0,25mm2
+01-B15	1	1005663	Reflex sensor	Sick	GL6-P4211
+01-B15	1	1002242	Reflector	Sick	C42-2
+01-B15	1	AE0036129	Reflective tape	Sick	REF-PLUS-R50
+01-B15	1	1003365	Proximity sensor	Sick	GTB6-P4211
+01-B15-W1	1	1003307	Prefab cable, PVC, 1 meter, connector M12 male + female M8, 4-pole	Murrelektronik	PVC-OB 4x0,25mm2
+01-U0	1	1003309	Passive plug-in terminal, 8-fold, 5-pole, M12	Murrelektronik	Exact12 8xM12 5-p
+01-U7	1	1003313	T-Coupler 5p Male M12 / 2x 4p Female M12, Distribution function	Murrelektronik	T-Coupler5p Male M12 / 2x 4p Female M12
+01-U7-W1	1	1001601	Prefab cable, PVC, 1 meter, connector M12 male 90°+ M12 female 90°, 4-pole	Murrelektronik	PVC-OB 4x0,34mm2
+01-Y2	1		See specification sheet		
+01-Y2-W1	1	1005959	Prefab cable, PVC, 0,3 meter, connector M12 male + female M8 straight 90°, 3-pole	Murrelektronik	PVC-OB 3x0,25mm2
+01-Y3	1		See specification sheet		
+01-Y3-W1	1	1005959	Prefab cable, PVC, 0,3 meter, connector M12 male + female M8 straight 90°, 3-pole	Murrelektronik	PVC-OB 3x0,25mm2
+03-M1	1		See specification sheet		

For technical specifications of gearmotor, applied options, machine configuration and other data see specification sheet.

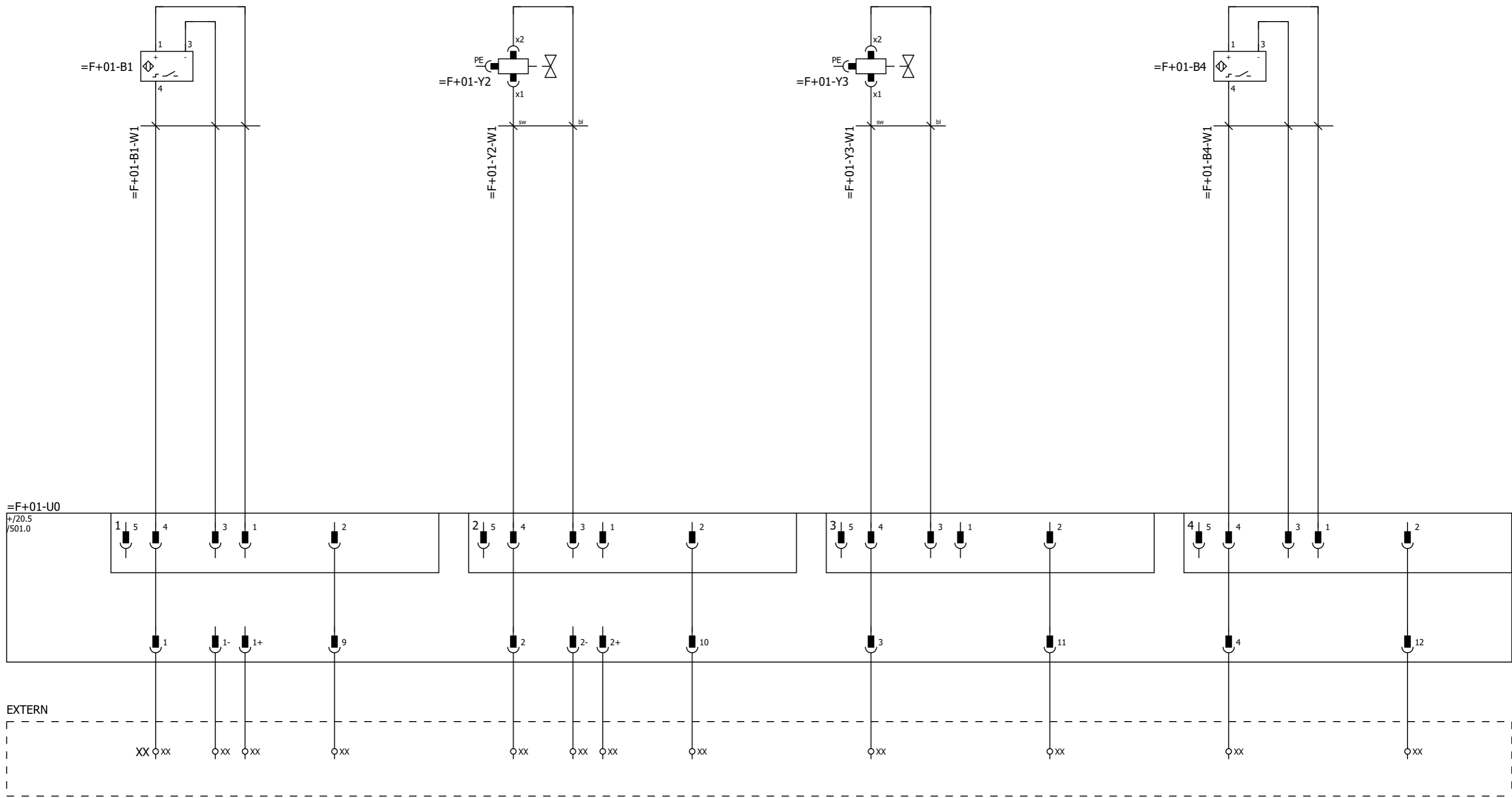

Passive plug-in terminal Multi belt conveyor MBC3 infeed

Wait position Spare Movement to wait position Spare Movement to infeed position Spare Infeed position Spare



Description of the project
PRmk5 (XL) Sorter conveyors
Standard

Page description
Field components

Mounting group MBC3 infeed
Mounting location Detection

Ed.	DSP	=	F
Date	20-12-2021	+	01
Version	v4.5.2		
			Page 500

For technical specifications of gearmotor, applied options, machine configuration and other data see specification sheet.

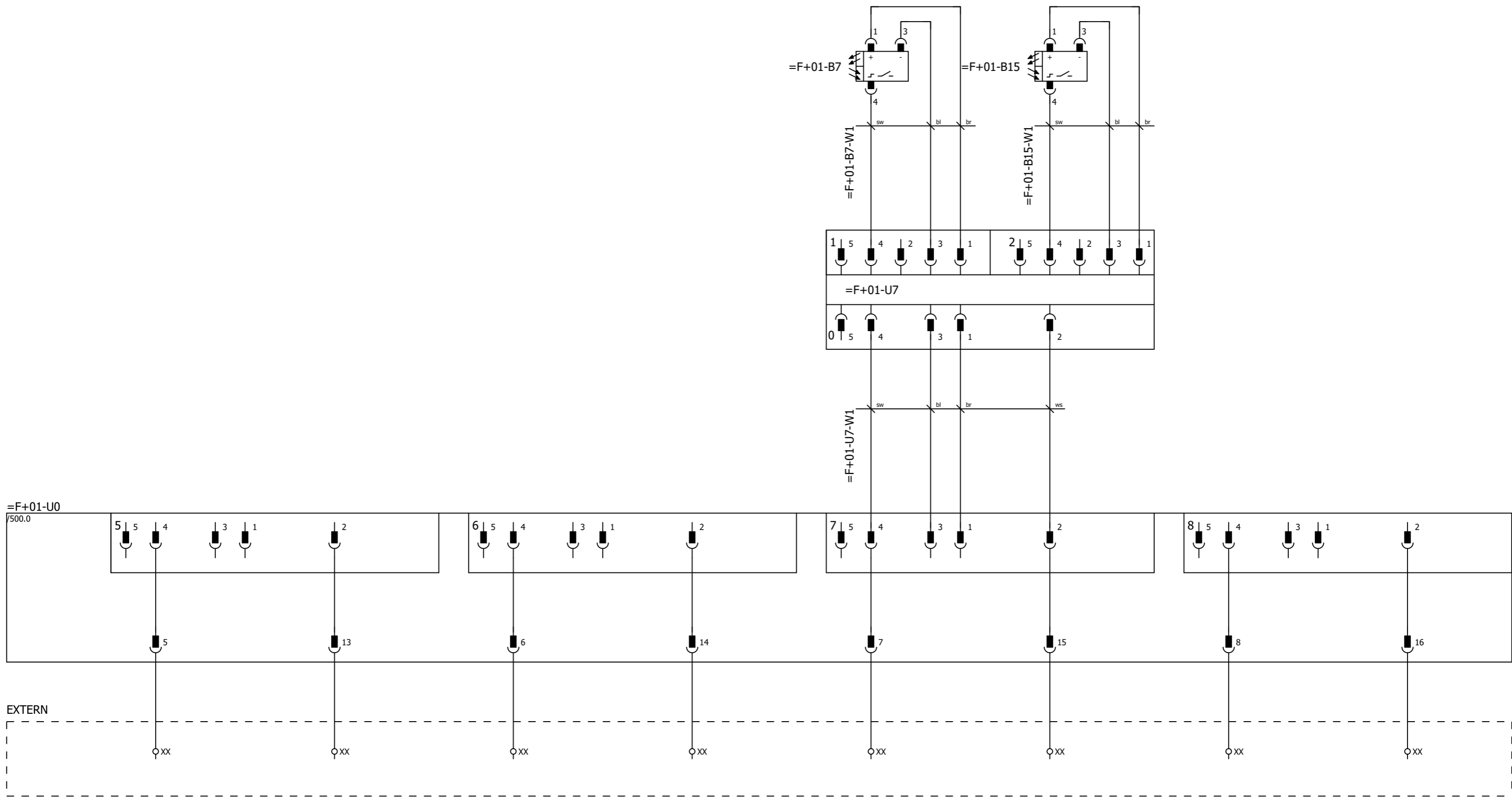

Passive plug-in terminal Multi belt conveyor MBC3 infeed

Spare Spare Spare Spare Product on infeed Product position monitoring Spare Spare

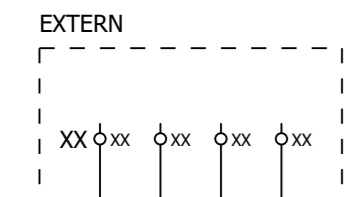

Connection gearmotor star

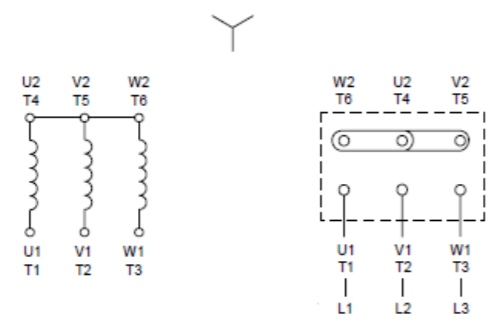

Connection gearmotor delta

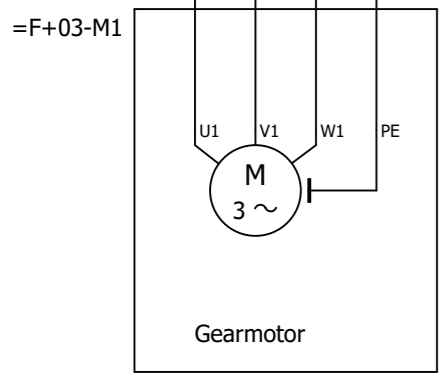
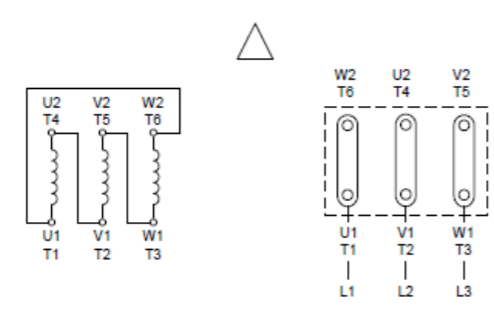

Gearmotor conveyor infeed

For technical specifications of gearmotor, applied options, machine configuration and other data see specification sheet.



Nobelstraat 43
3846 CE Harderwijk
The Netherlands

Phone: +31 341 - 436700
Fax: +31 341 - 436701
www.qimarox.com
info@qimarox.com

Document name: Electrical drawings PRmk5 (XL) Sorter conveyors v4.5.2
Mounting group: MBC3 outfeed
Type: Standard

Power supply: See specification sheet
Control voltage: 24VDC
According to: NEN-EN-IEC 60204-1: 2018

Version number: v4.5.2

Table of contents

Mounting group		Mounting location		Page	Page description
=G	MBC3 outfeed			1	Title page
				2	Table of contents
				10	Layout Multi belt conveyor MBC3 outfeed
				20	Overview passive plug-in terminal MBC3 outfeed
				2000	Parts list
		+01	Detection	500	Field components
		+01	Detection	501	Field components
		+03	Drive conveyor	150	Gearmotor, 3 fase

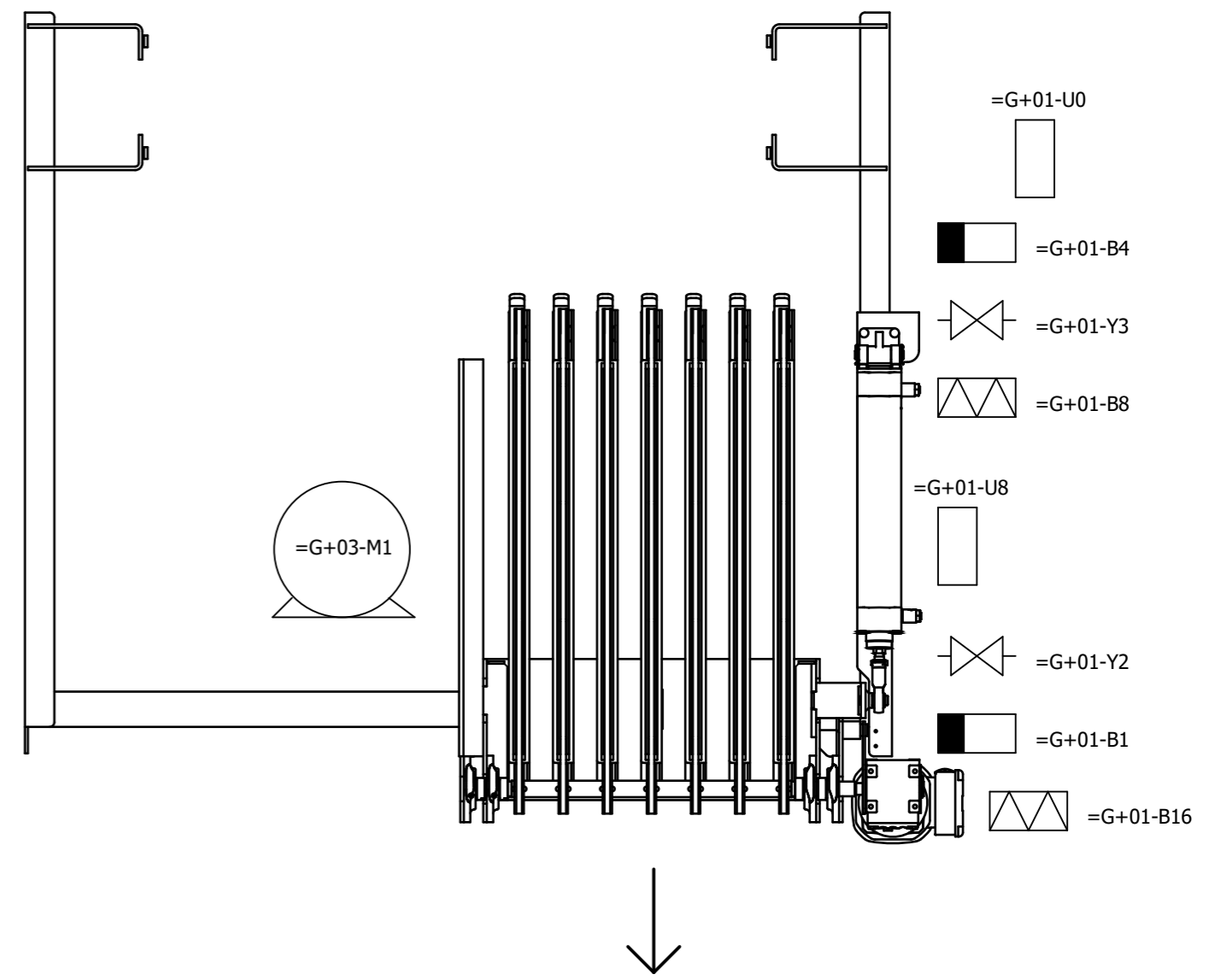
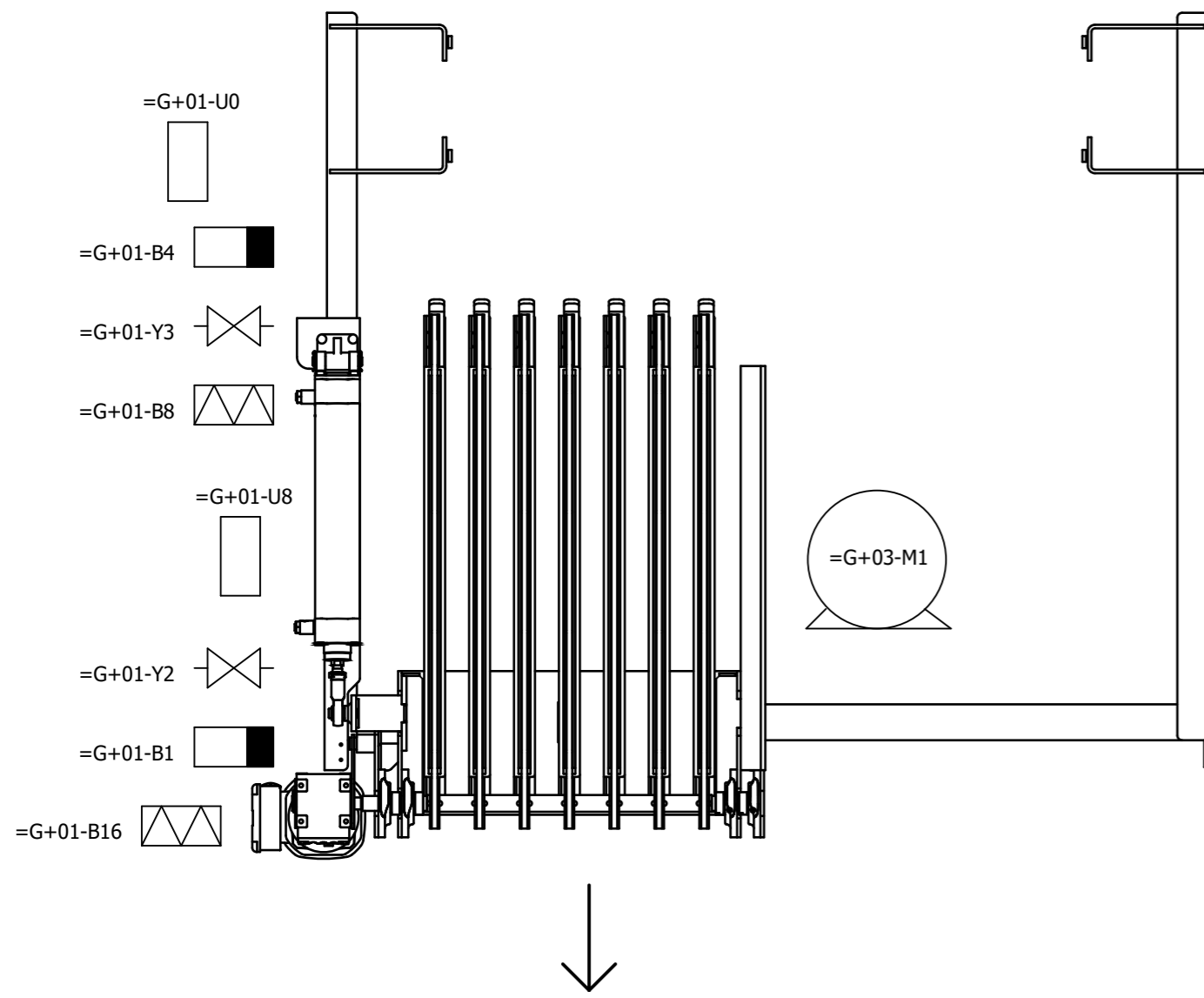

Legend:

- =G+03-M1 Gearmotor conveyor outfeed

- =G+01-B1 Wait position
- =G+01-Y2 Movement to wait position
- =G+01-Y3 Movement to outfeed position
- =G+01-B4 Outfeed position
- =G+01-B8 Product on outfeed
- =G+01-B16 Product has left the outfeed

- =G+01-U0 Passive plug-in terminal Multi belt conveyor MBC3 outfeed
- =G+01-U8 T-coupler outfeed

For technical specifications of gearmotor, applied options, machine configuration and other data see specification sheet.

Image may differ from reality.

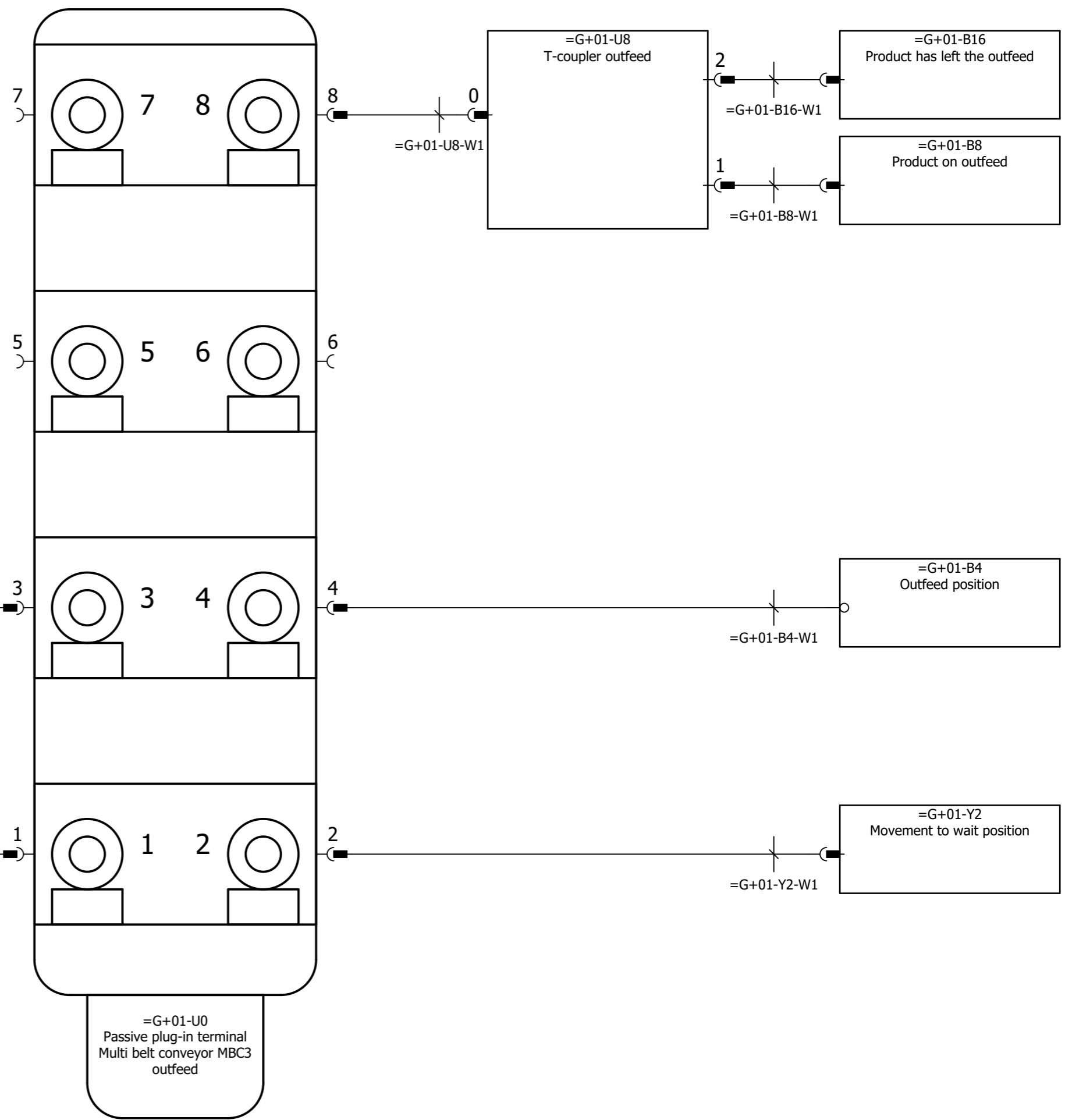

For technical specifications of gearmotor, applied options, machine configuration and other data see specification sheet.

Parts list

Position	Quantity	Article number	Description	Manufacturer	Type number
+01-B1	1	1007850	Proximity Sensor	Festo	SMT-8M-A-PS-24V-E-1-N-M12
+01-B4	1	1007850	Proximity Sensor	Festo	SMT-8M-A-PS-24V-E-1-N-M12
+01-B8	1	1005663	Reflex sensor	Sick	GL6-P4211
+01-B8	1	1002242	Reflector	Sick	C42-2
+01-B8	1	AE0036129	Reflective tape	Sick	REF-PLUS-R50
+01-B8	1	1003365	Proximity sensor	Sick	GTB6-P4211
+01-B8-W1	1	1003307	Prefab cable, PVC, 1 meter, connector M12 male + female M8, 4-pole	Murrelektronik	PVC-OB 4x0,25mm2
+01-B16	1	1005663	Reflex sensor	Sick	GL6-P4211
+01-B16	1	1002242	Reflector	Sick	C42-2
+01-B16	1	AE0036129	Reflective tape	Sick	REF-PLUS-R50
+01-B16	1	1003365	Proximity sensor	Sick	GTB6-P4211
+01-B16-W1	1	1003307	Prefab cable, PVC, 1 meter, connector M12 male + female M8, 4-pole	Murrelektronik	PVC-OB 4x0,25mm2
+01-U0	1	1003309	Passive plug-in terminal, 8-fold, 5-pole, M12	Murrelektronik	Exact12 8xM12 5-p
+01-U8	1	1003313	T-Coupler 5p Male M12 / 2x 4p Female M12, Distribution function	Murrelektronik	T-Coupler5p Male M12 / 2x 4p Female M12
+01-U8-W1	1	1001601	Prefab cable, PVC, 1 meter, connector M12 male 90°+ M12 female 90°, 4-pole	Murrelektronik	PVC-OB 4x0,34mm2
+01-Y2	1		Coil see mechanical part list	Qimarox	
+01-Y2-W1	1	1005959	Prefab cable, PVC, 0,3 meter, connector M12 male + female M8 straight 90°, 3-pole	Murrelektronik	PVC-OB 3x0,25mm2
+01-Y3	1		Coil see mechanical part list	Qimarox	
+01-Y3-W1	1	1005959	Prefab cable, PVC, 0,3 meter, connector M12 male + female M8 straight 90°, 3-pole	Murrelektronik	PVC-OB 3x0,25mm2
+03-M1	1		See specification sheet		

For technical specifications of gearmotor, applied options, machine configuration and other data see specification sheet.

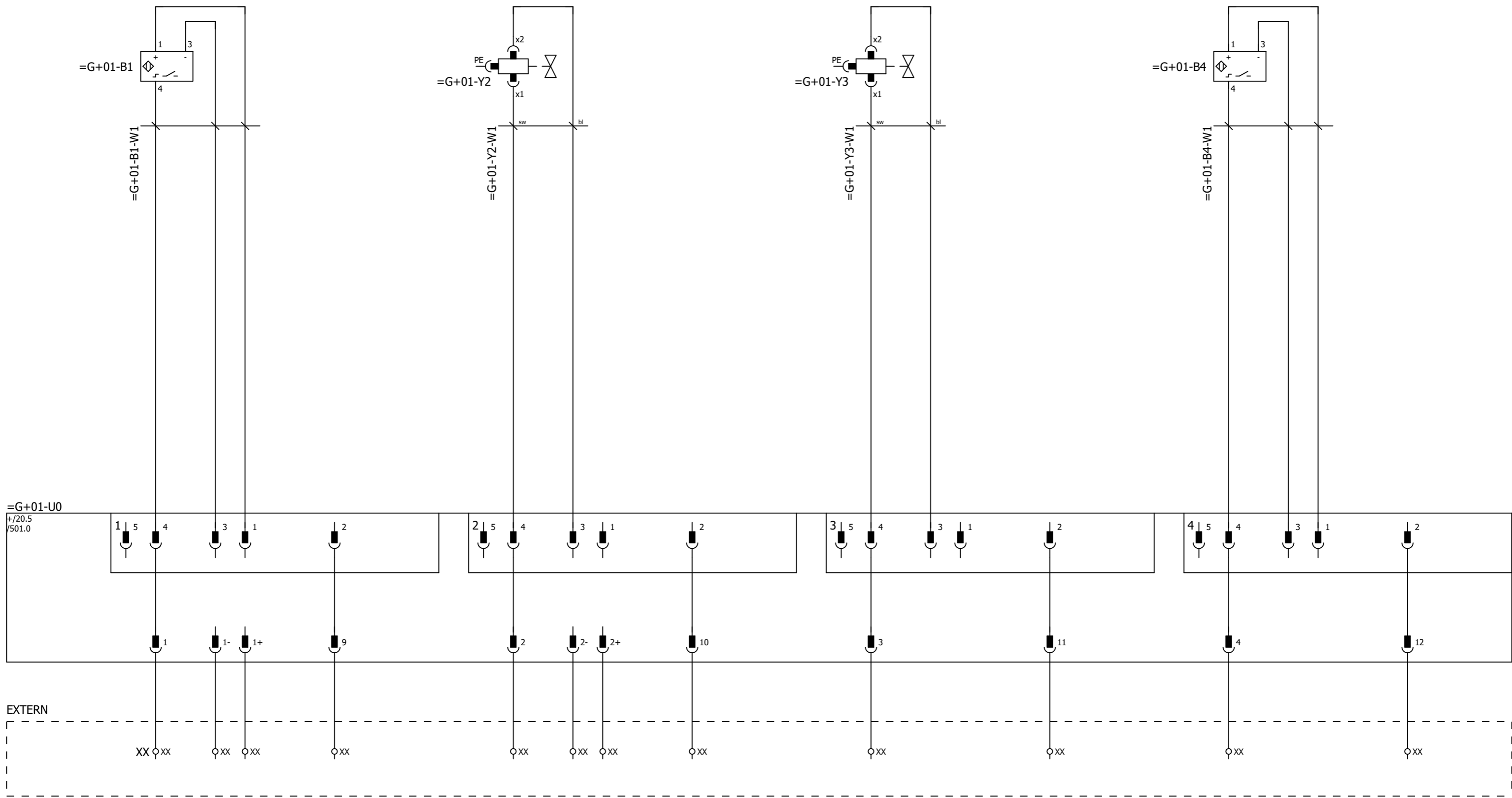

Passive plug-in terminal Multi belt conveyor MBC3 outfeed

Wait position Spare Movement to wait position Spare Movement to outfeed position Spare Outfeed position Spare



Description of the project
PRmk5 (XL) Sorter conveyors
 Standard

Page description
 Field components

Mounting group **MBC3 outfeed**
 Mounting location **Detection**

Ed.	DSP	=	G
Date	20-12-2021	+	01
Version	v4.5.2		
			Page 500

For technical specifications of gearmotor, applied options, machine configuration and other data see specification sheet.

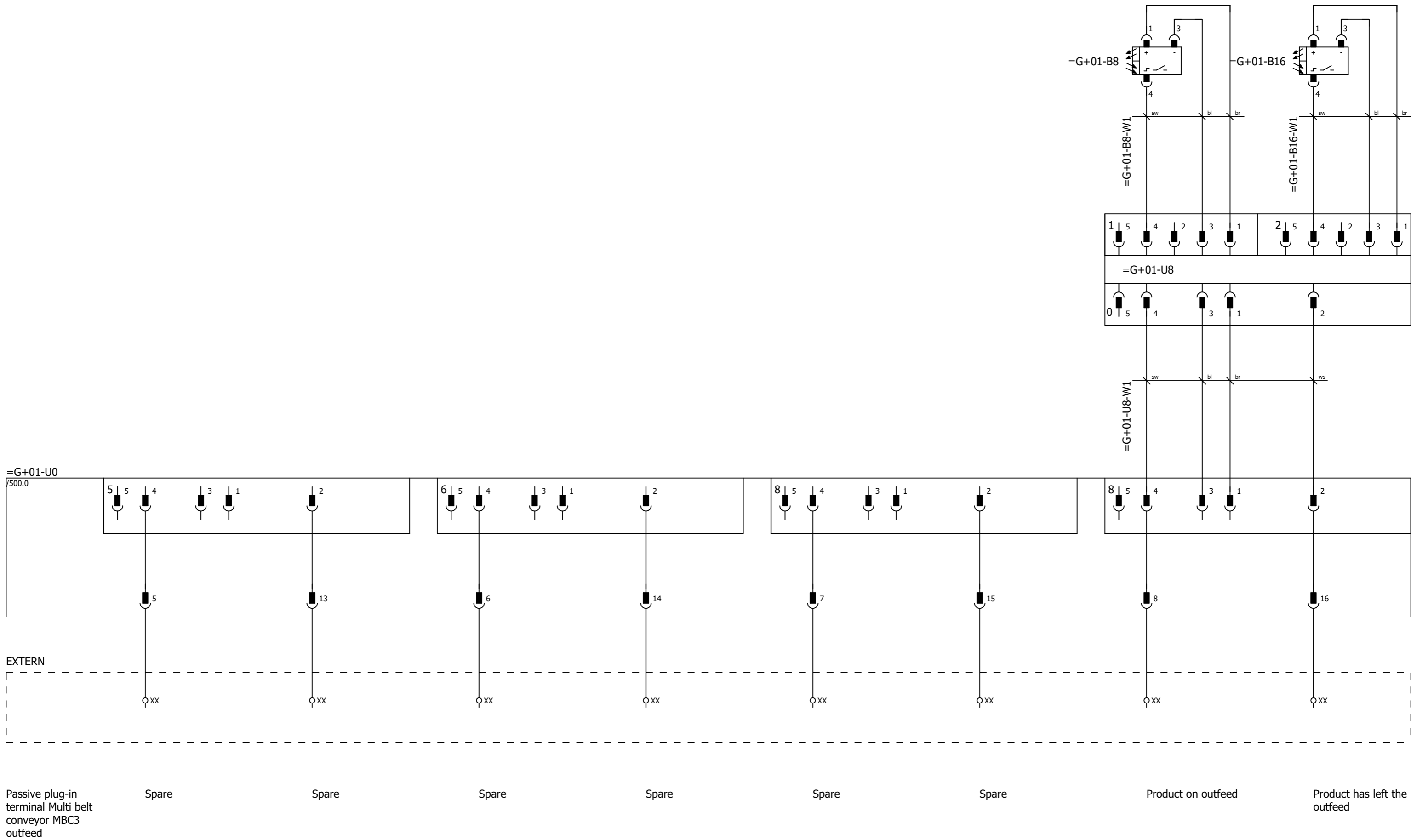

Passive plug-in terminal Multi belt conveyor MBC3 outfeed

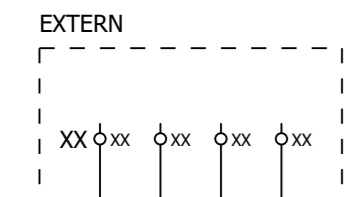

Connection gearmotor star

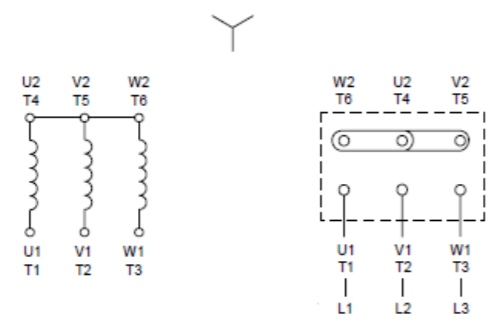

Connection gearmotor delta

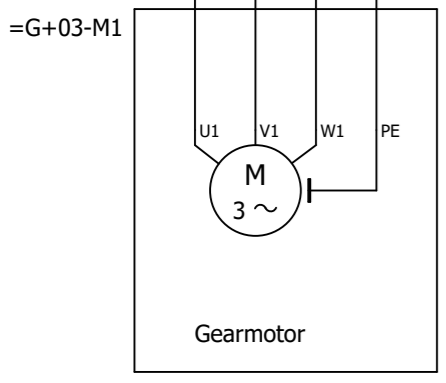
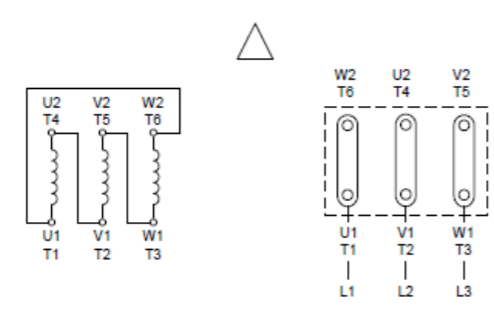

Gearmotor conveyor outfeed

For technical specifications of gearmotor, applied options, machine configuration and other data see specification sheet.



Nobelstraat 43
3846 CE Harderwijk
The Netherlands

Phone: +31 341 - 436700
Fax: +31 341 - 436701
www.qimarox.com
info@qimarox.com

Document name: Electrical drawings PRmk5 (XL) Sorter conveyors v4.5.2
Mounting group: MBC4 infeed
Type: Standard

Power supply: See specification sheet
Control voltage: 24VDC
According to: NEN-EN-IEC 60204-1: 2018

Version number: v4.5.2

Table of contents

Mounting group		Mounting location		Page	Page description
=H	MBC4 infeed			1	Title page
				2	Table of contents
				10	Layout Multi belt conveyor MBC4 infeed
				20	Overview passive plug-in terminal MBC4 infeed
				2000	Parts list
		+01	Detection	500	Field components
		+01	Detection	501	Field components
		+02	Drive shuttle	150	Gearmotor, 3 fase
		+03	Drive conveyor	150	Gearmotor, 3 fase

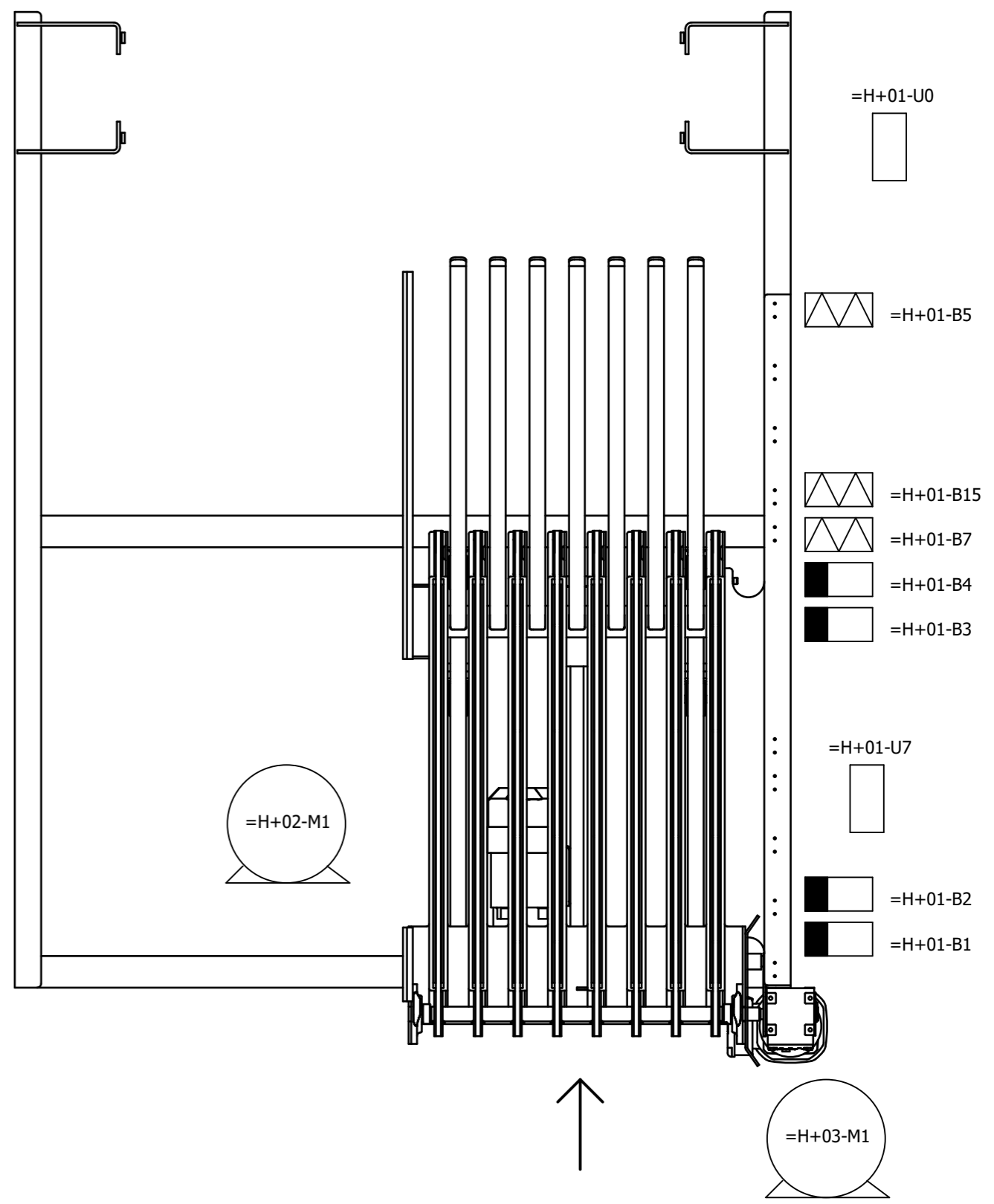
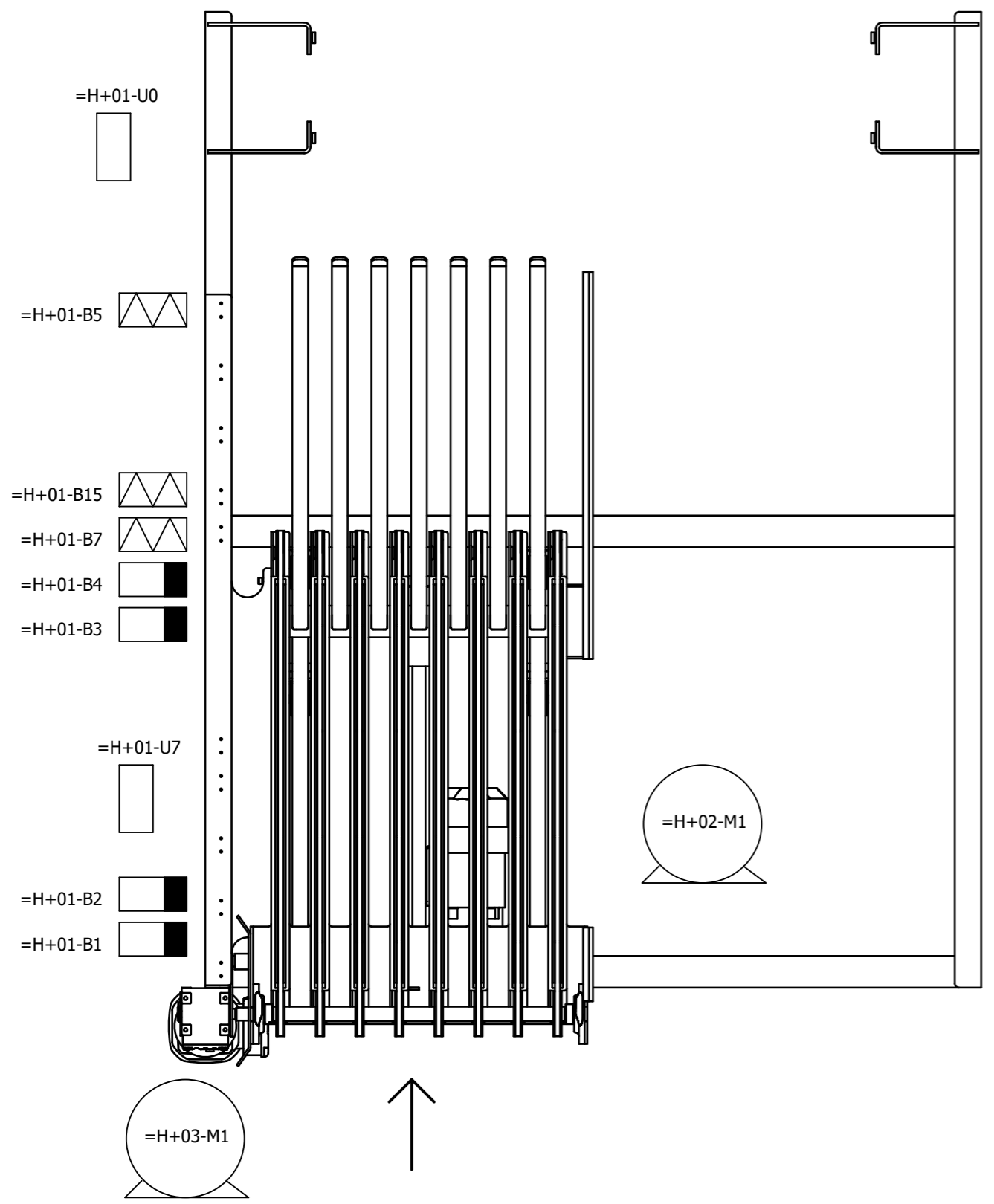

Legend:

- | | | | | | |
|----------|----------------------------|-----------|------------------------------|----------|--|
| =H+02-M1 | Gearmotor shuttle movement | =H+01-B1 | Wait position | =H+01-U0 | Passive plug-in terminal Multi belt conveyor MBC4 infeed |
| =H+03-M1 | Gearmotor conveyor infeed | =H+01-B2 | Low speed to wait position | =H+01-U7 | T-coupler infeed |
| | | =H+01-B3 | Low speed to infeed position | | |
| | | =H+01-B4 | Infeed position | | |
| | | =H+01-B5 | Product picked up | | |
| | | =H+01-B7 | Product on infeed | | |
| | | =H+01-B15 | Product position monitoring | | |

For technical specifications of gearmotor, applied options, machine configuration and other data see specification sheet.

Image may differ from reality.

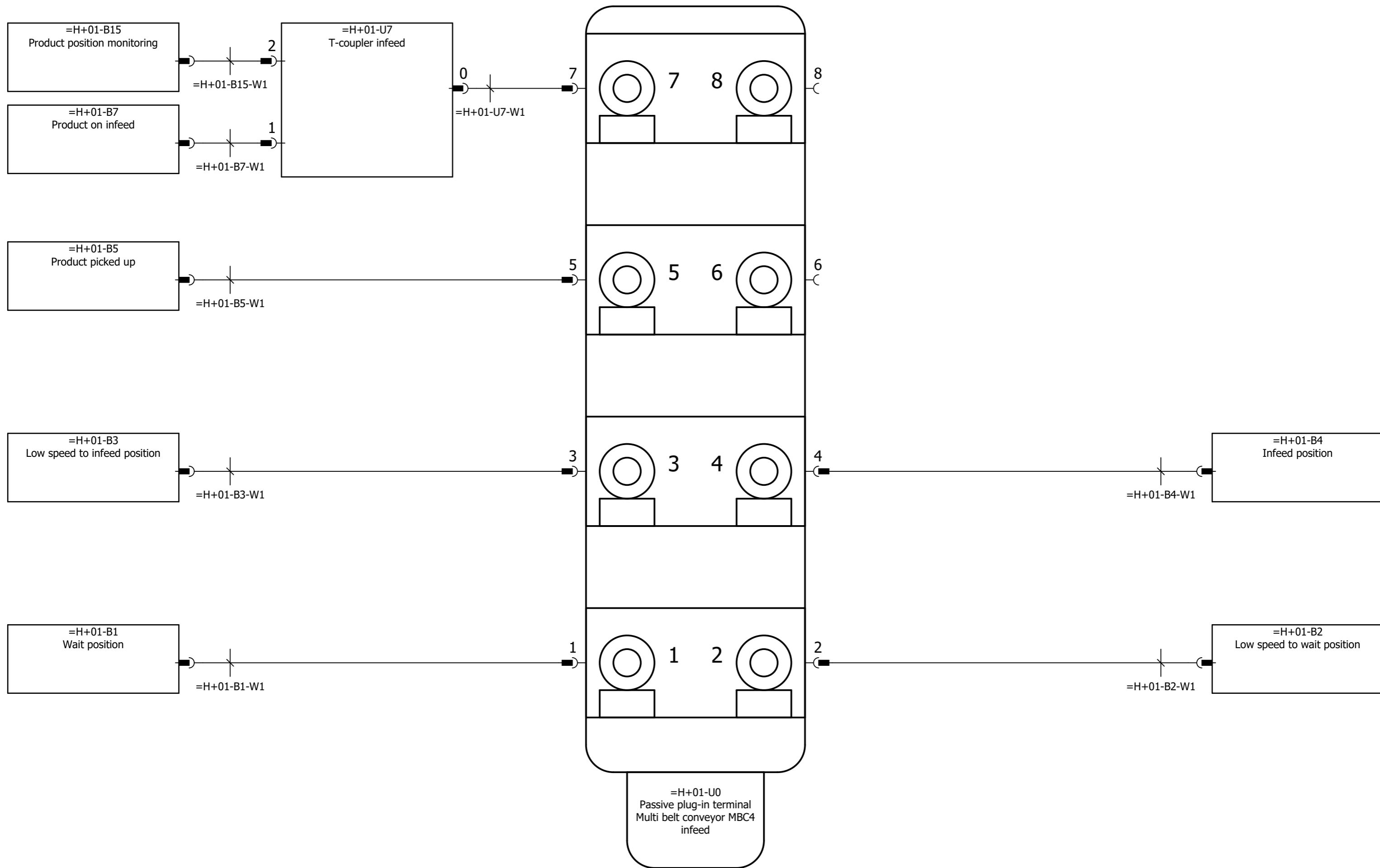

For technical specifications of gearmotor, applied options, machine configuration and other data see specification sheet.

Parts list

Position	Quantity	Article number	Description	Manufacturer	Type number
+01-B1	1	1000932	Inductive proximity sensor	Sick	IME18-08BPSZC0K
+01-B1-W1	1	1001528	Prefab cable, PVC, 2 meter, connector M12 male 90°+ M12 female 90°, 4-pole	Murrelektronik	PVC-OB 4x0,34mm2
+01-B2	1	1000932	Inductive proximity sensor	Sick	IME18-08BPSZC0K
+01-B2-W1	1	1001528	Prefab cable, PVC, 2 meter, connector M12 male 90°+ M12 female 90°, 4-pole	Murrelektronik	PVC-OB 4x0,34mm2
+01-B3	1	1000932	Inductive proximity sensor	Sick	IME18-08BPSZC0K
+01-B3-W1	1	1001601	Prefab cable, PVC, 1 meter, connector M12 male 90°+ M12 female 90°, 4-pole	Murrelektronik	PVC-OB 4x0,34mm2
+01-B4	1	1000932	Inductive proximity sensor	Sick	IME18-08BPSZC0K
+01-B4-W1	1	1001601	Prefab cable, PVC, 1 meter, connector M12 male 90°+ M12 female 90°, 4-pole	Murrelektronik	PVC-OB 4x0,34mm2
+01-B5	1	1005663	Reflex sensor	Sick	GL6-P4211
+01-B5	1	AE0036129	Reflective tape	Sick	REF-PLUS-R50
+01-B5-W1	1	1003307	Prefab cable, PVC, 1 meter, connector M12 male + female M8, 4-pole	Murrelektronik	PVC-OB 4x0,25mm2
+01-B7	1	1005663	Reflex sensor	Sick	GL6-P4211
+01-B7-W1	1	1003307	Prefab cable, PVC, 1 meter, connector M12 male + female M8, 4-pole	Murrelektronik	PVC-OB 4x0,25mm2
+01-B15	1	1005663	Reflex sensor	Sick	GL6-P4211
+01-B15-W1	1	1003307	Prefab cable, PVC, 1 meter, connector M12 male + female M8, 4-pole	Murrelektronik	PVC-OB 4x0,25mm2
+01-U0	1	1003309	Passive plug-in terminal, 8-fold, 5-pole, M12	Murrelektronik	Exact12 8xM12 5-p
+01-U7	1	1003313	T-Coupler 5p Male M12 / 2x 4p Female M12, Distribution function	Murrelektronik	T-Coupler5p Male M12 / 2x 4p Female M12
+01-U7-W1	1	1001601	Prefab cable, PVC, 1 meter, connector M12 male 90°+ M12 female 90°, 4-pole	Murrelektronik	PVC-OB 4x0,34mm2
+02-M1	1		See specification sheet		
+03-M1	1		See specification sheet		

For technical specifications of gearmotor, applied options, machine configuration and other data see specification sheet.

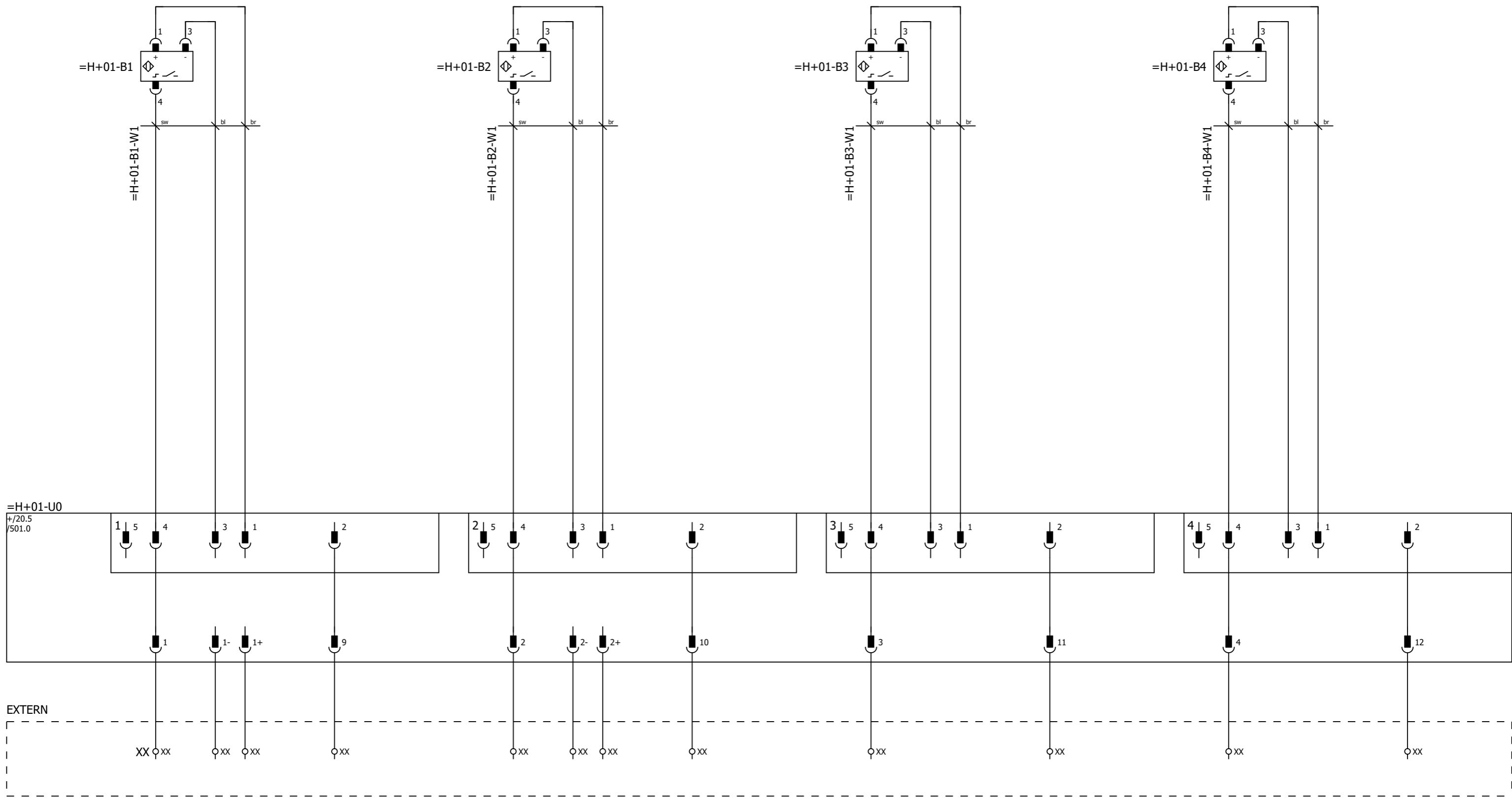

Passive plug-in terminal Multi belt conveyor MBC4 infeed

Wait position Spare Low speed to wait position Spare Low speed to infeed position Spare Infeed position Spare



Description of the project
PRmk5 (XL) Sorter conveyors
Standard

Page description
Field components

Mounting group MBC4 infeed
Mounting location Detection

Ed.	DSP	=	H
Date	20-12-2021	+	01
Version	v4.5.2		
			Page 500

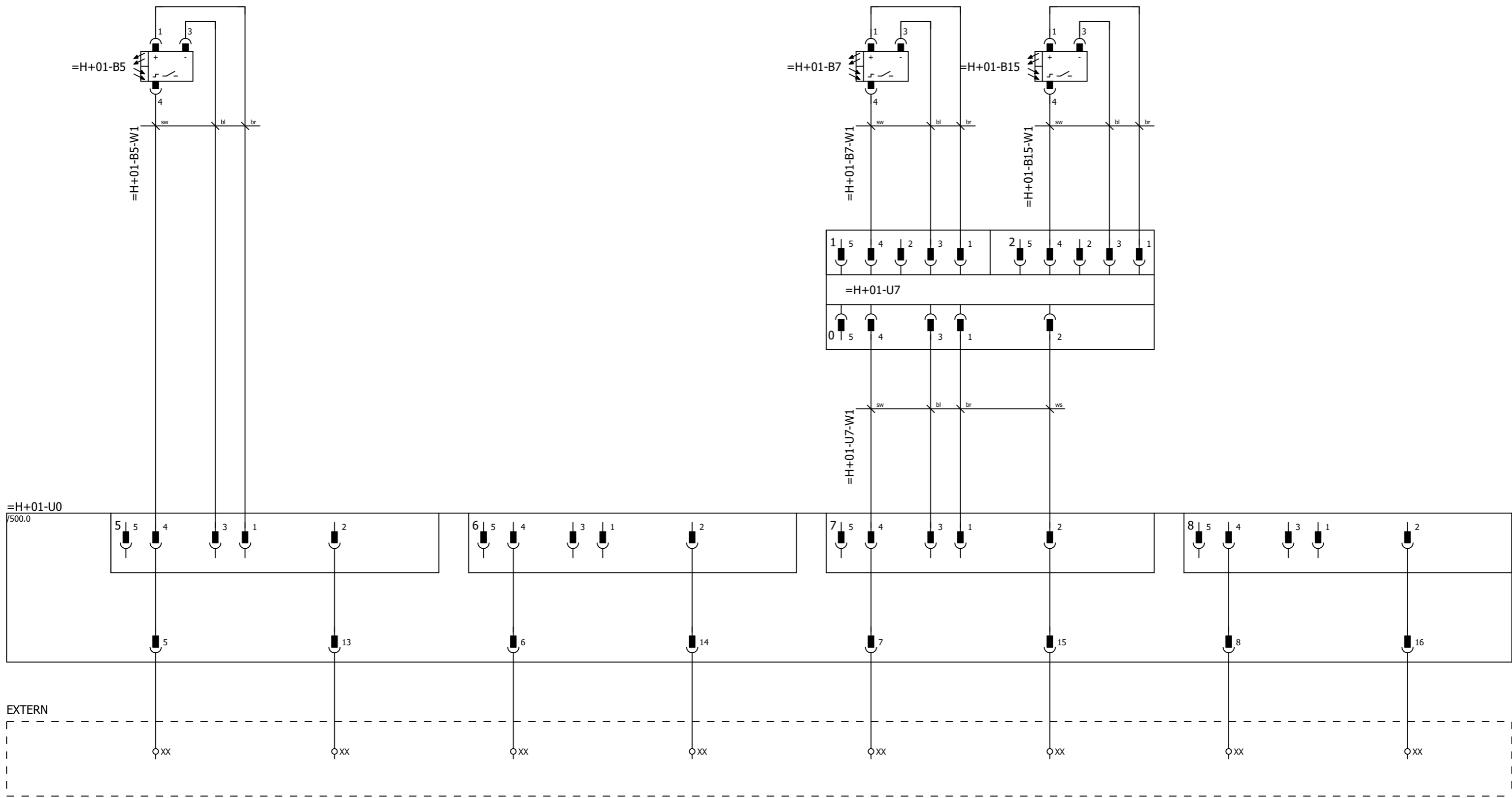

	Product picked up	Spare	Spare	Spare	Product on infeed	Product position monitoring	Spare	Spare
--	-------------------	-------	-------	-------	-------------------	-----------------------------	-------	-------



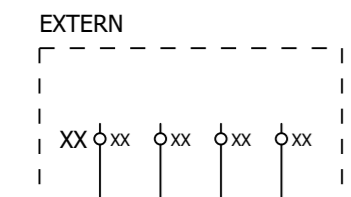

Connection gearmotor star

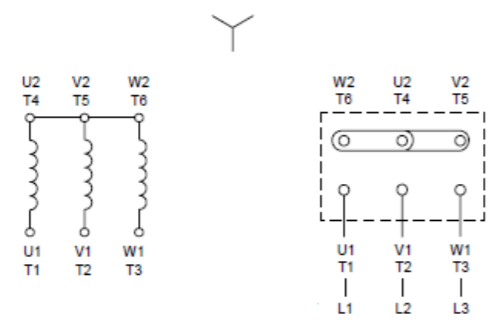

Connection gearmotor delta

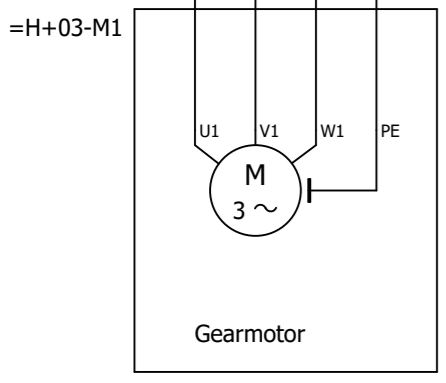
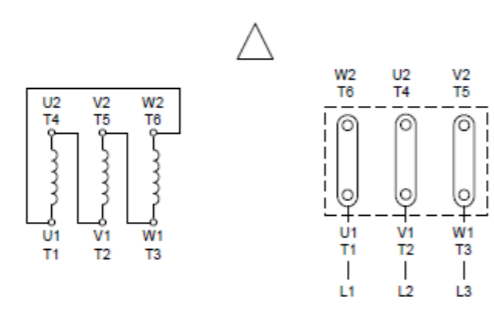

Gearmotor conveyor infeed

For technical specifications of gearmotor, applied options, machine configuration and other data see specification sheet.



Nobelstraat 43
3846 CE Harderwijk
The Netherlands

Phone: +31 341 - 436700
Fax: +31 341 - 436701
www.qimarox.com
info@qimarox.com

Document name: Electrical drawings PRmk5 (XL) Sorter conveyors v4.5.2
Mounting group: MBC4 outfeed
Type: Standard

Power supply: See specification sheet
Control voltage: 24VDC
According to: NEN-EN-IEC 60204-1: 2018

Version number: v4.5.2

Table of contents

Mounting group		Mounting location		Page	Page description
=I	MBC4 outfeed			1	Title page
				2	Table of contents
				10	Layout Multi belt conveyor MBC4 outfeed
				20	Overview passive plug-in terminal MBC4 outfeed
				2000	Parts list
		+01	Detection	500	Field components
		+01	Detection	501	Field components
		+02	Drive shuttle	150	Gearmotor, 3 fase
		+03	Drive conveyor	150	Gearmotor, 3 fase

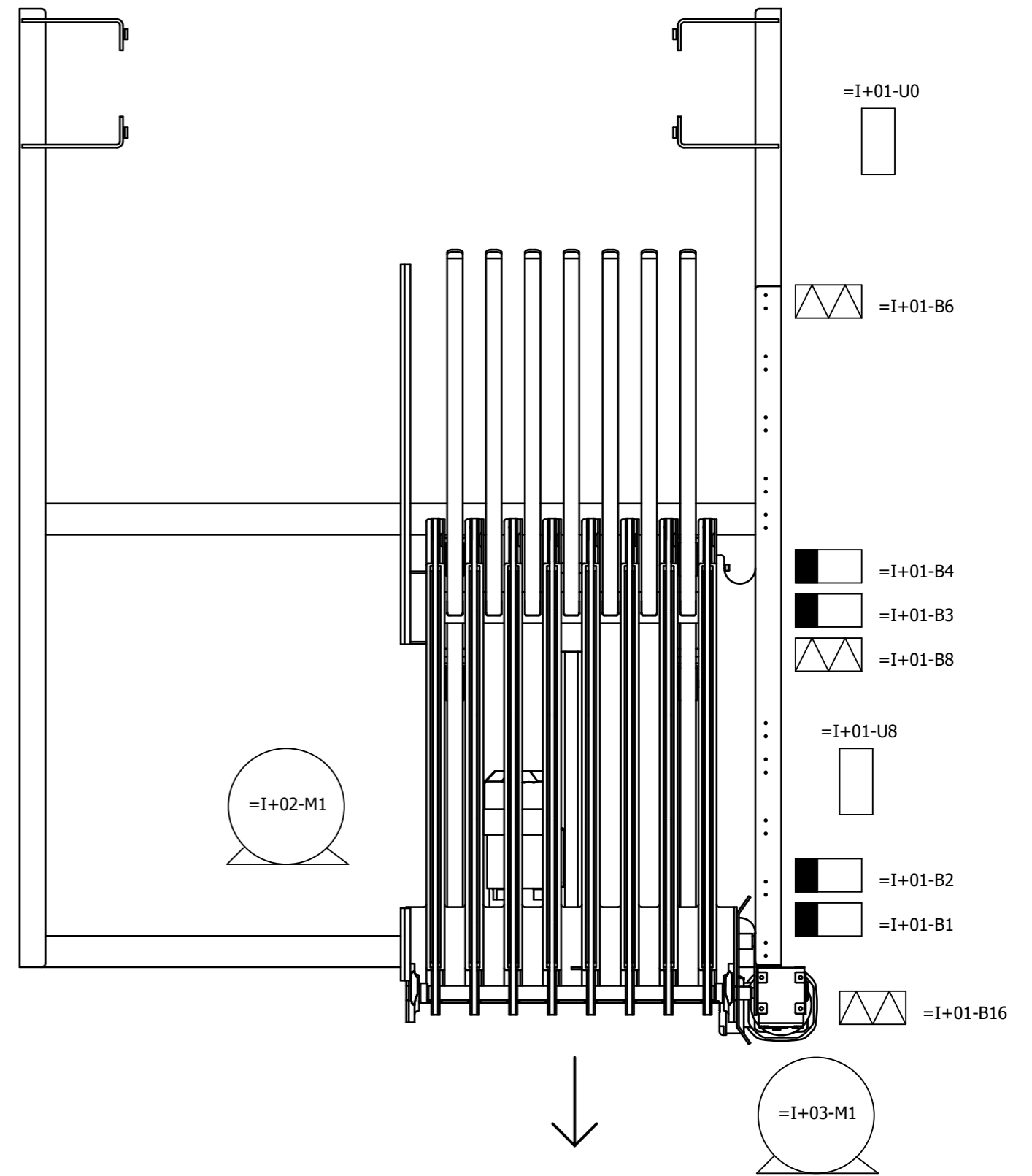
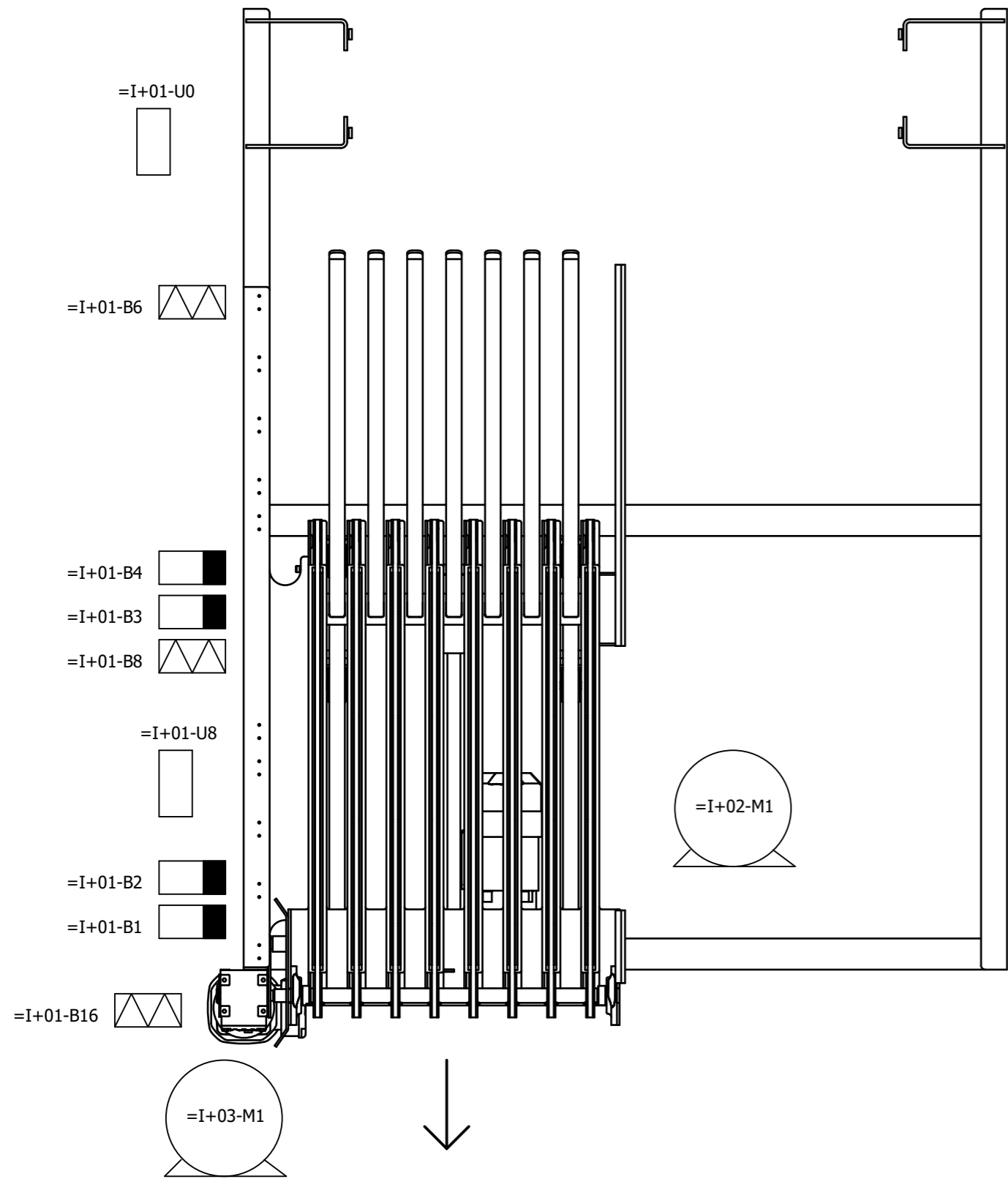

Legend:

- | | | | | | |
|----------|----------------------------|-----------|-------------------------------|----------|---|
| =I+02-M1 | Gearmotor shuttle movement | =I+01-B1 | Wait position | =I+01-U0 | Passive plug-in terminal Multi belt conveyor MBC4 outfeed |
| =I+03-M1 | Gearmotor conveyor outfeed | =I+01-B2 | Low speed to wait position | =I+01-U8 | T-coupler outfeed |
| | | =I+01-B3 | Low speed to outfeed position | | |
| | | =I+01-B4 | Outfeed position | | |
| | | =I+01-B6 | Product dropped of | | |
| | | =I+01-B8 | Product on outfeed | | |
| | | =I+01-B16 | Product has left the outfeed | | |

For technical specifications of gearmotor, applied options, machine configuration and other data see specification sheet.

Image may differ from reality.

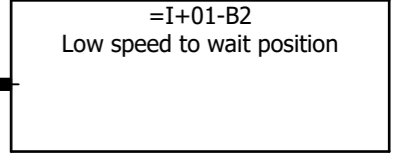
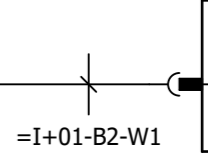
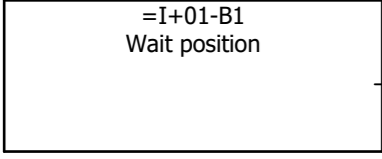
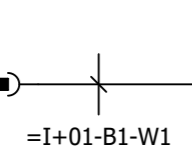
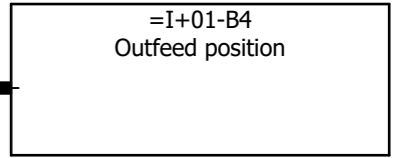
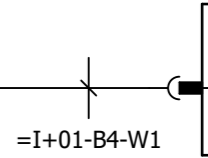
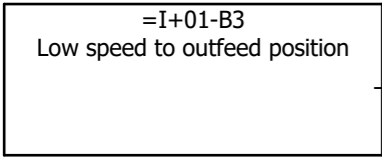
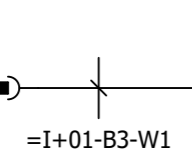
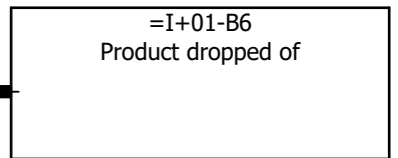
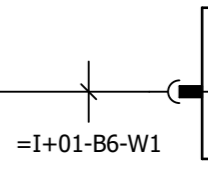
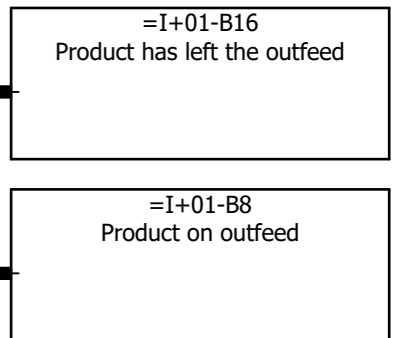
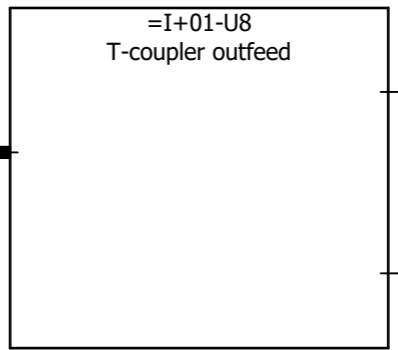
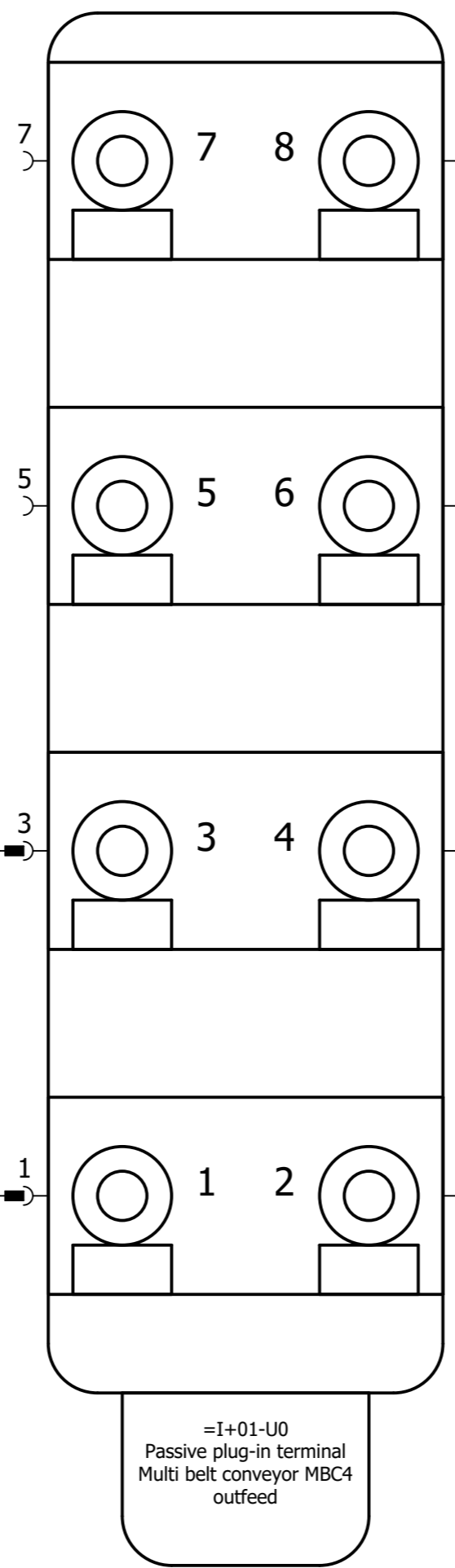

=I+01-U0
Passive plug-in terminal
Multi belt conveyor MBC4
outfeed

For technical specifications of gearmotor, applied options, machine configuration and other data see specification sheet.

Parts list

Position	Quantity	Article number	Description	Manufacturer	Type number
+01-B1	1	1000932	Inductive proximity sensor	Sick	IME18-08BPSZC0K
+01-B1-W1	1	1001528	Prefab cable, PVC, 2 meter, connector M12 male 90°+ M12 female 90°, 4-pole	Murrelektronik	PVC-OB 4x0,34mm2
+01-B2	1	1000932	Inductive proximity sensor	Sick	IME18-08BPSZC0K
+01-B2-W1	1	1001528	Prefab cable, PVC, 2 meter, connector M12 male 90°+ M12 female 90°, 4-pole	Murrelektronik	PVC-OB 4x0,34mm2
+01-B3	1	1000932	Inductive proximity sensor	Sick	IME18-08BPSZC0K
+01-B3-W1	1	1001601	Prefab cable, PVC, 1 meter, connector M12 male 90°+ M12 female 90°, 4-pole	Murrelektronik	PVC-OB 4x0,34mm2
+01-B4	1	1000932	Inductive proximity sensor	Sick	IME18-08BPSZC0K
+01-B4-W1	1	1001601	Prefab cable, PVC, 1 meter, connector M12 male 90°+ M12 female 90°, 4-pole	Murrelektronik	PVC-OB 4x0,34mm2
+01-B6	1	1005663	Reflex sensor	Sick	GL6-P4211
+01-B6	1	AE0036129	Reflective tape	Sick	REF-PLUS-R50
+01-B6-W1	1	1003307	Prefab cable, PVC, 1 meter, connector M12 male + female M8, 4-pole	Murrelektronik	PVC-OB 4x0,25mm2
+01-B8	1	1005663	Reflex sensor	Sick	GL6-P4211
+01-B8-W1	1	1003307	Prefab cable, PVC, 1 meter, connector M12 male + female M8, 4-pole	Murrelektronik	PVC-OB 4x0,25mm2
+01-B16	1	1005663	Reflex sensor	Sick	GL6-P4211
+01-B16-W1	1	1003307	Prefab cable, PVC, 1 meter, connector M12 male + female M8, 4-pole	Murrelektronik	PVC-OB 4x0,25mm2
+01-U0	1	1003309	Passive plug-in terminal, 8-fold, 5-pole, M12	Murrelektronik	Exact12 8xM12 5-p
+01-U8	1	1003313	T-Coupler 5p Male M12 / 2x 4p Female M12, Distribution function	Murrelektronik	T-Coupler5p Male M12 / 2x 4p Female M12
+01-U8-W1	1	1001601	Prefab cable, PVC, 1 meter, connector M12 male 90°+ M12 female 90°, 4-pole	Murrelektronik	PVC-OB 4x0,34mm2
+02-M1	1		See specification sheet		
+03-M1	1		See specification sheet		

For technical specifications of gearmotor, applied options, machine configuration and other data see specification sheet.

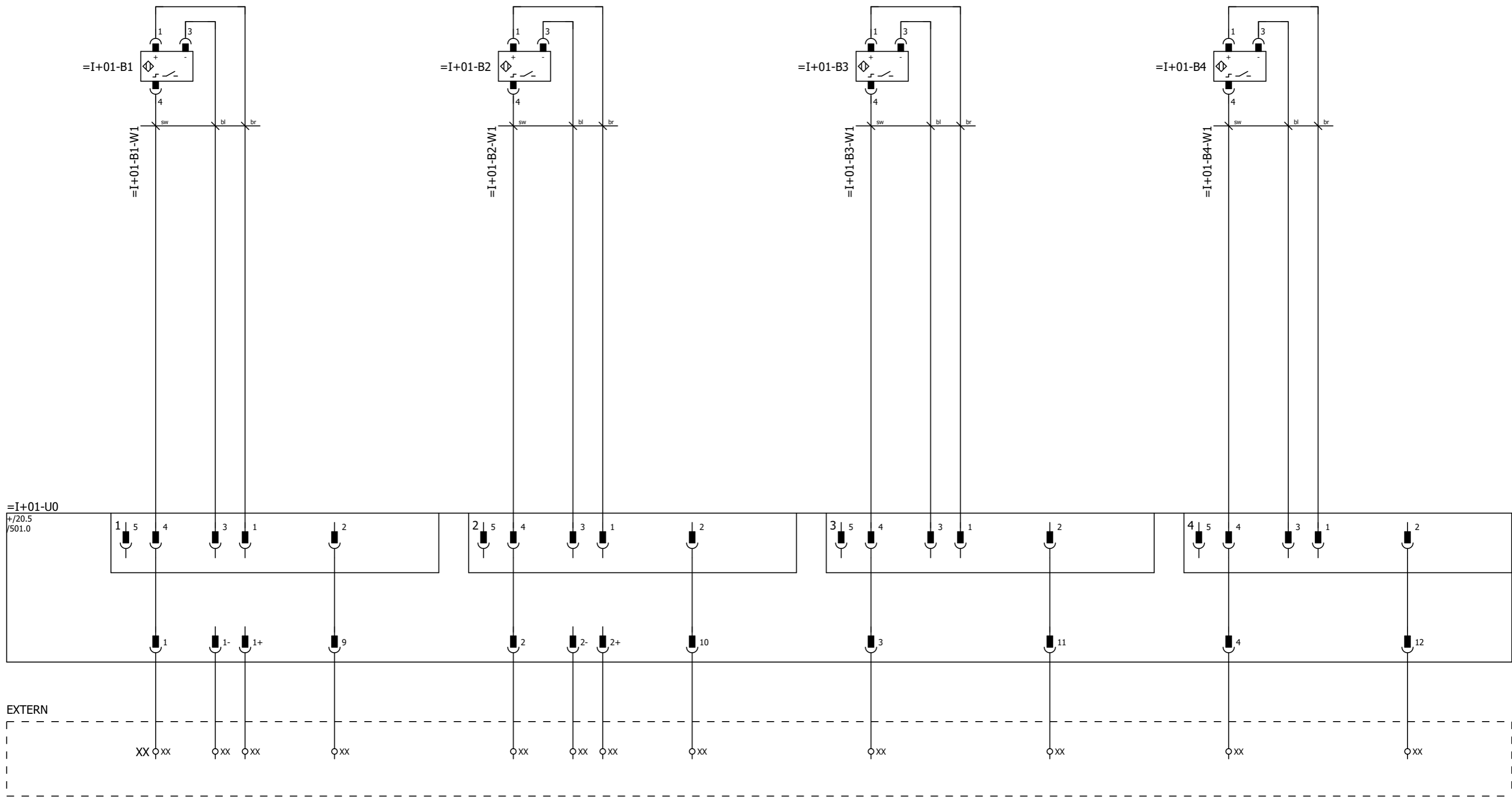

Passive plug-in terminal Multi belt conveyor MBC4 outfeed

Wait position Spare Low speed to wait position Spare Low speed to outfeed position Spare Outfeed position Spare



Description of the project
PRmk5 (XL) Sorter conveyors
Standard

Page description
Field components

Mounting group
MBC4 outfeed

Mounting location
Detection

Ed.	DSP	=	I
Date	20-12-2021	+	01
Version	v4.5.2		
			Page 500

For technical specifications of gearmotor, applied options, machine configuration and other data see specification sheet.

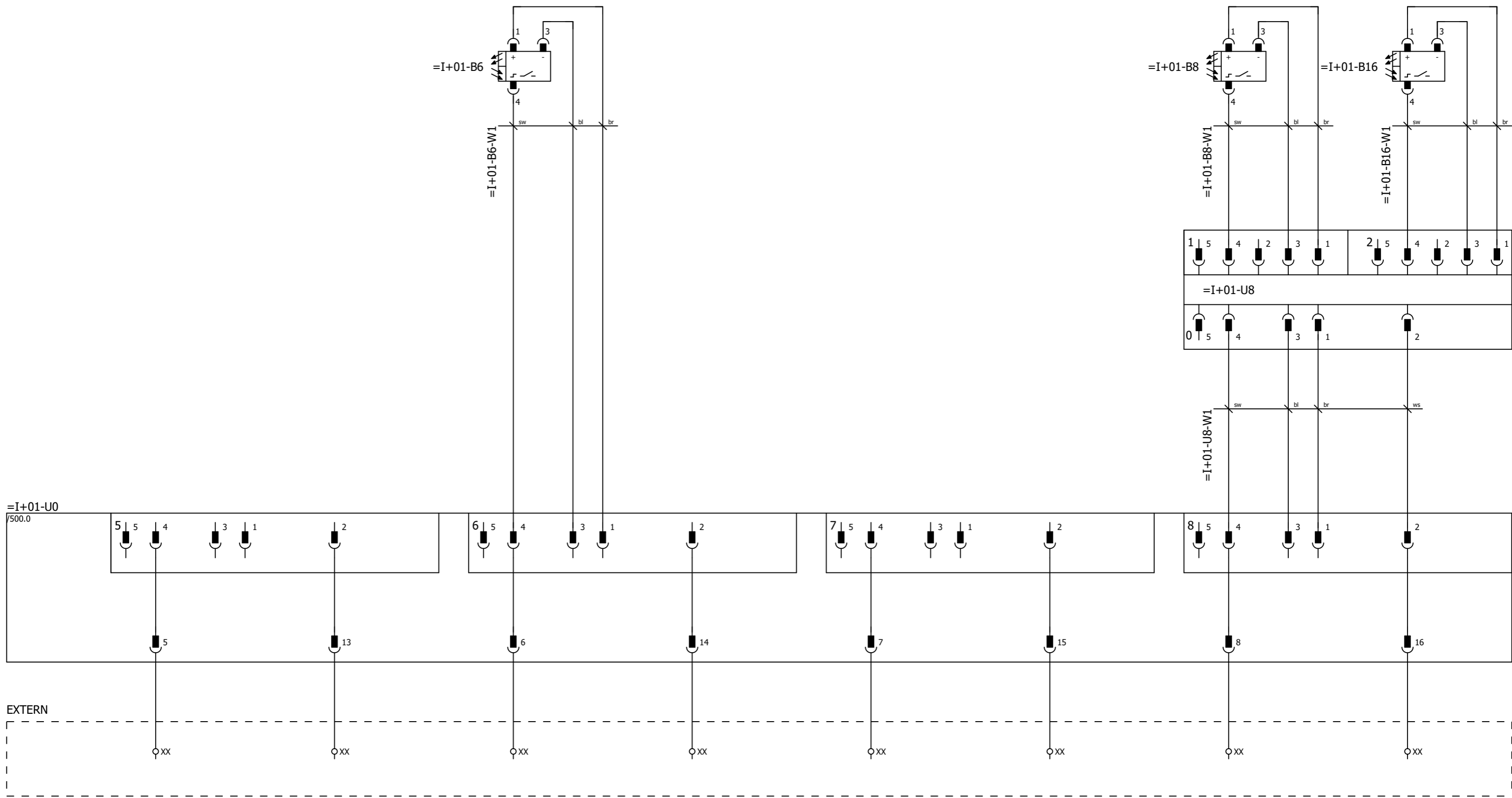

Passive plug-in terminal Multi belt conveyor MBC4 outfeed Spare Spare Product dropped of Spare Spare Spare Product on outfeed Product has left the outfeed



Description of the project
PRmk5 (XL) Sorter conveyors
Standard

Page description
Field components

Mounting group: MBC4 outfeed
Mounting location: Detection

Ed.	DSP	=	I
Date	11-10-2022	+	01
Version	v4.5.2		
			Page 501

EXTERN

Alternative

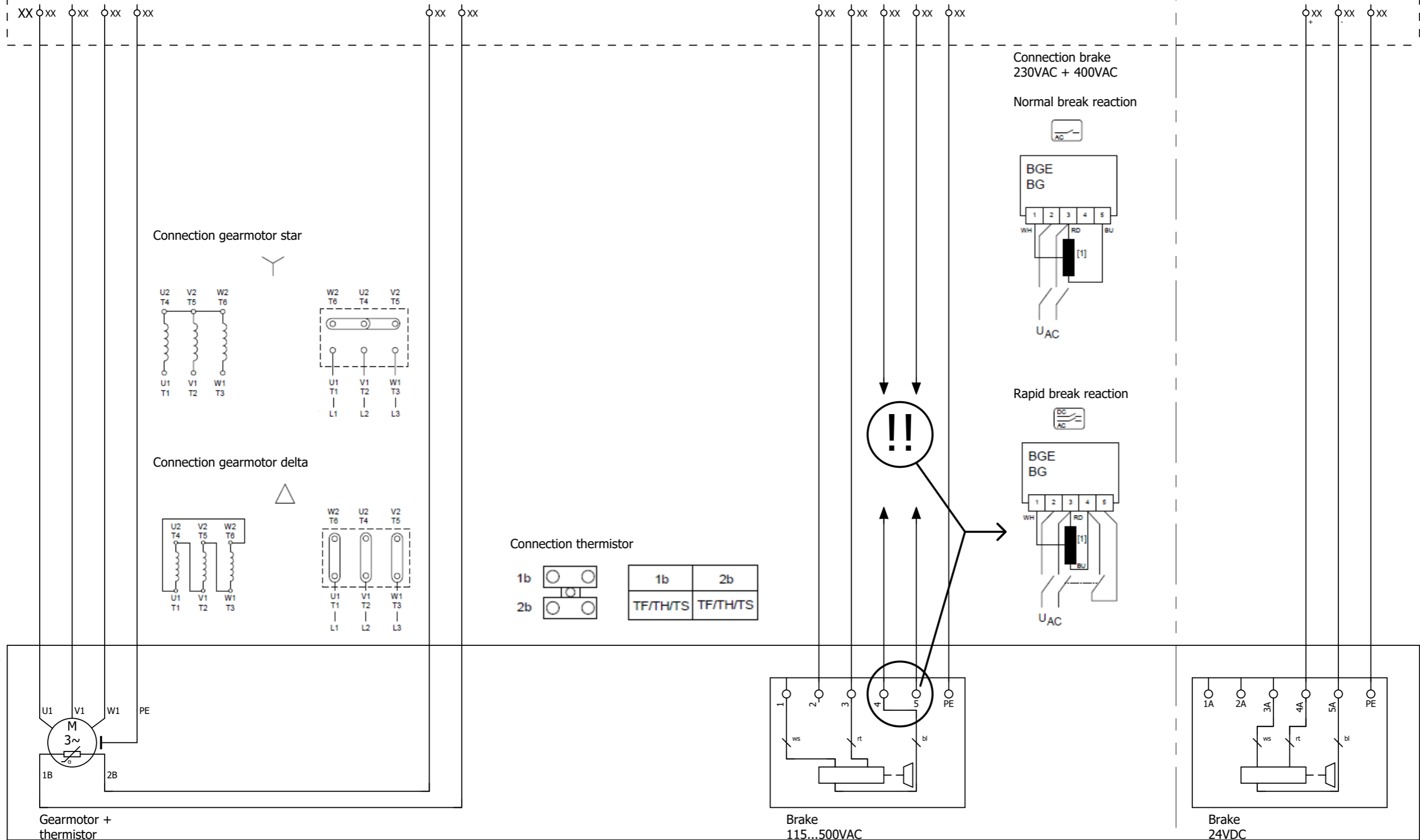

=I+02-M1

Gearmotor shuttle movement

For technical specifications of gearmotor, applied options, machine configuration and other data see specification sheet.

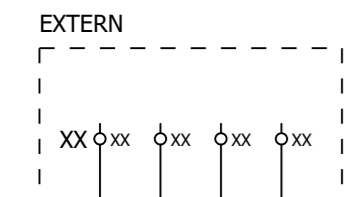

Connection gearmotor star

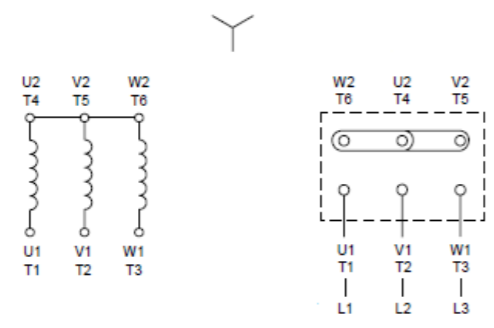

Connection gearmotor delta

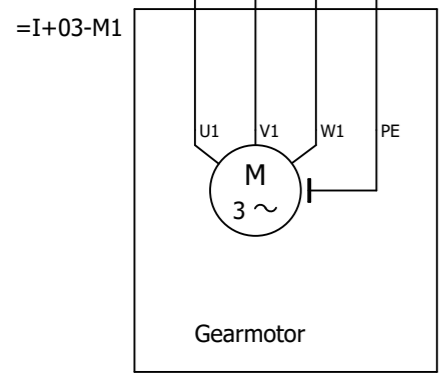
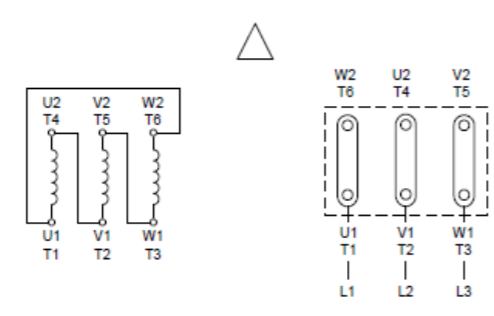

Gearmotor conveyor outfeed

For technical specifications of gearmotor, applied options, machine configuration and other data see specification sheet.



Nobelstraat 43
3846 CE Harderwijk
The Netherlands

Phone: +31 341 - 436700
Fax: +31 341 - 436701
www.qimarox.com
info@qimarox.com

Document name: Electrical drawings PRmk5 (XL) Sorter conveyors v4.5.2
Mounting group: BDC4 infeed
Type: Standard

Power supply: See specification sheet
Control voltage: 24VDC
According to: NEN-EN-IEC 60204-1: 2018

Version number: v4.5.2

Table of contents

Mounting group		Mounting location		Page	Page description
=L	BDC4 infeed			1	Title page
				2	Table of contents
				10	Layout Belt driven conveyor BDC4 infeed
				20	Overview passive plug-in terminal BDC4 infeed
				2000	Parts list
		+01	Detection	500	Field components
		+01	Detection	501	Field components
		+02	Drive shuttle	150	Gearmotor, 3 fase
		+03	Drive conveyor	150	Gearmotor, 3 fase

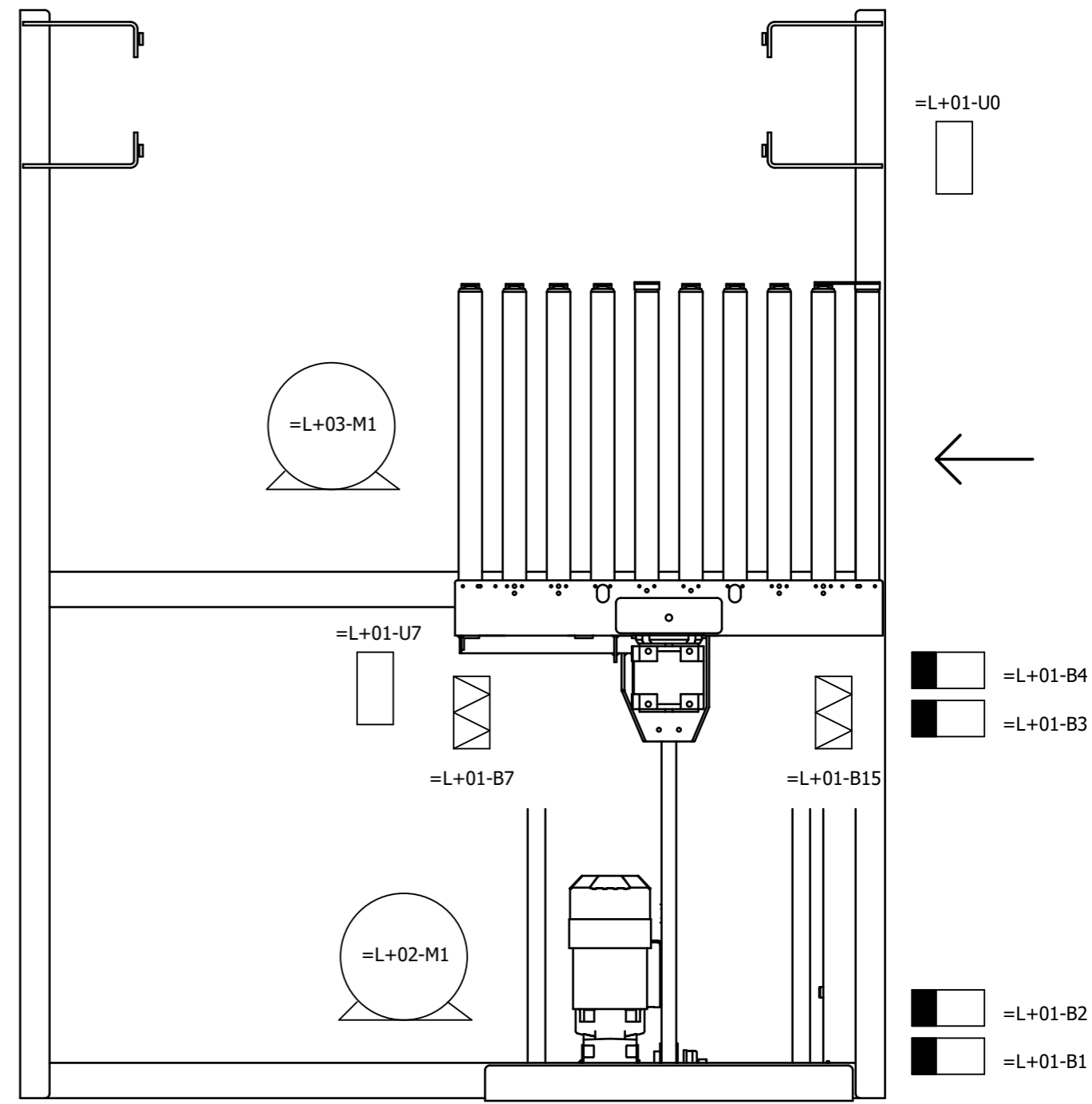
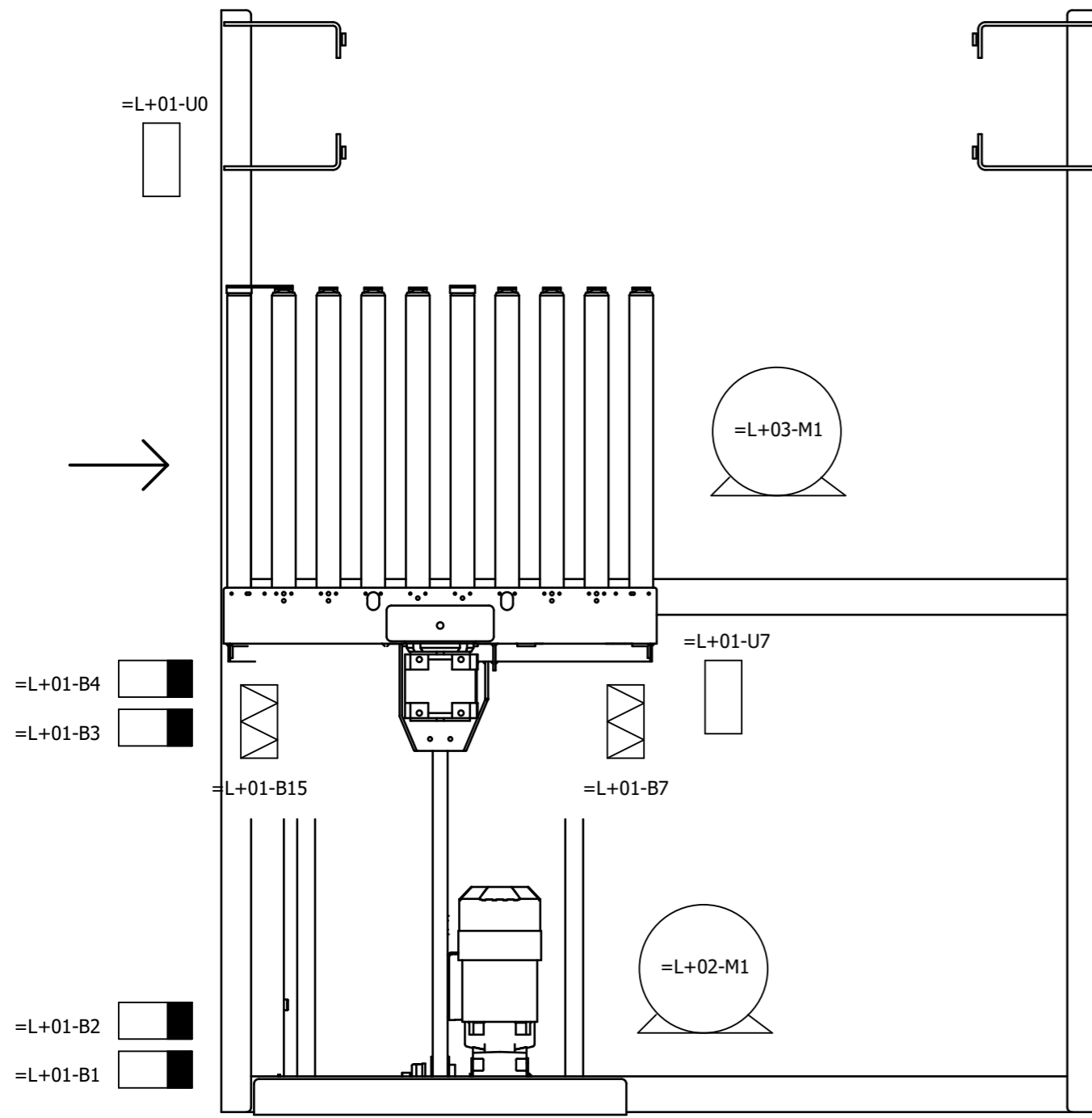

Legend:

- =L+02-M1 Gearmotor shuttle movement
- =L+03-M1 Gearmotor conveyor infeed

- =L+01-B1 Wait position
- =L+01-B2 Low speed to wait position
- =L+01-B3 Low speed to infeed position
- =L+01-B4 Infeed position
- =L+01-B7 Product on infeed
- =L+01-B15 Product position monitoring

- =L+01-U0 Passive plug-in terminal Belt driven conveyor BDC4 infeed
- =L+01-U7 T-coupler infeed

For technical specifications of gearmotor, applied options, machine configuration and other data see specification sheet.

Image may differ from reality.

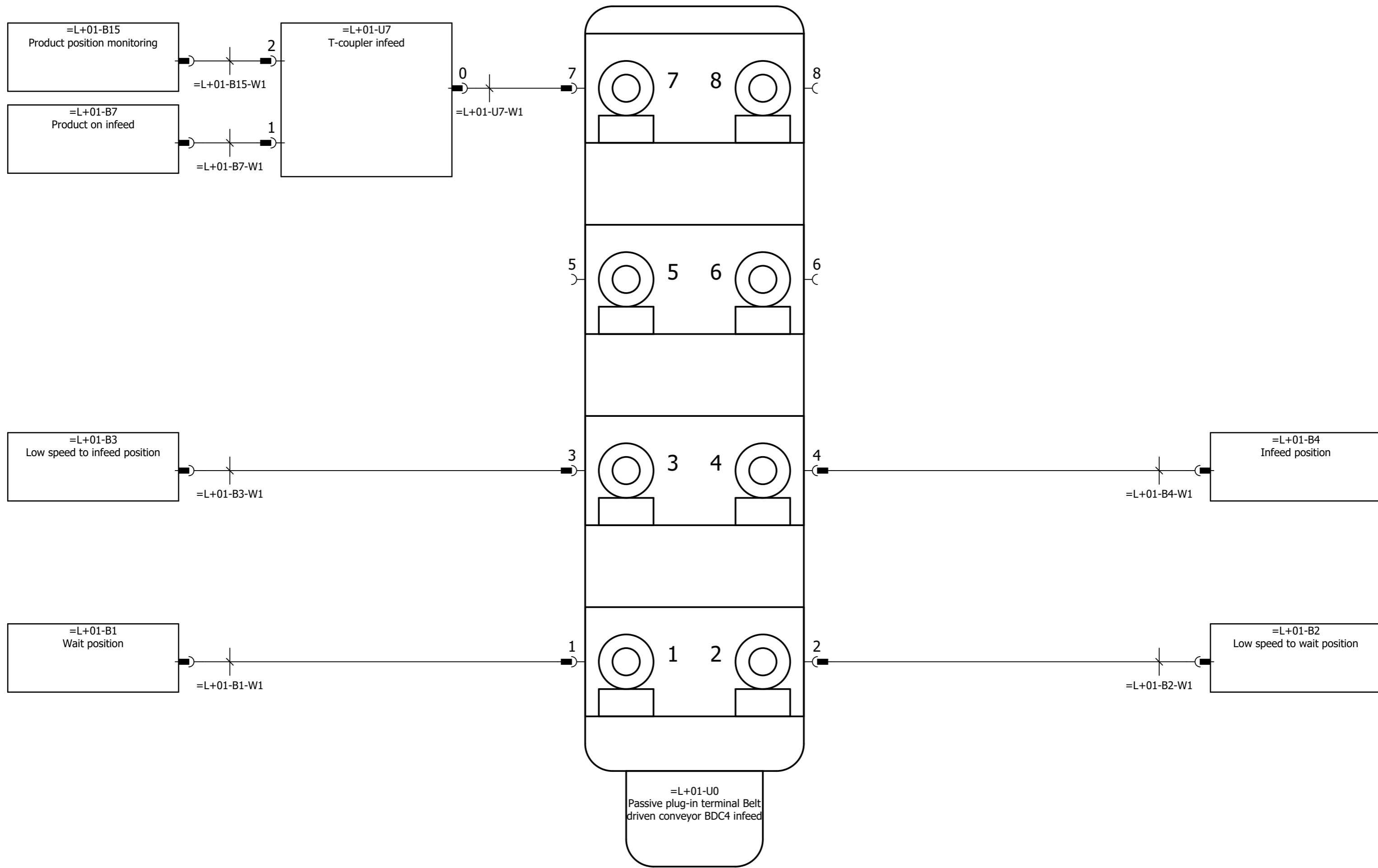

For technical specifications of gearmotor, applied options, machine configuration and other data see specification sheet.

Parts list

Position	Quantity	Article number	Description	Manufacturer	Type number
+01-B1	1	1000932	Inductive proximity sensor	Sick	IME18-08BPSZC0K
+01-B1-W1	1	1001528	Prefab cable, PVC, 2 meter, connector M12 male 90°+ M12 female 90°, 4-pole	Murrelektronik	PVC-OB 4x0,34mm2
+01-B2	1	1000932	Inductive proximity sensor	Sick	IME18-08BPSZC0K
+01-B2-W1	1	1001528	Prefab cable, PVC, 2 meter, connector M12 male 90°+ M12 female 90°, 4-pole	Murrelektronik	PVC-OB 4x0,34mm2
+01-B3	1	1000932	Inductive proximity sensor	Sick	IME18-08BPSZC0K
+01-B3-W1	1	1001601	Prefab cable, PVC, 1 meter, connector M12 male 90°+ M12 female 90°, 4-pole	Murrelektronik	PVC-OB 4x0,34mm2
+01-B4	1	1000932	Inductive proximity sensor	Sick	IME18-08BPSZC0K
+01-B4-W1	1	1001601	Prefab cable, PVC, 1 meter, connector M12 male 90°+ M12 female 90°, 4-pole	Murrelektronik	PVC-OB 4x0,34mm2
+01-B7	1	1005663	Reflex sensor	Sick	GL6-P4211
+01-B7	1	1002242	Reflector	Sick	C42-2
+01-B7-W1	1	1003307	Prefab cable, PVC, 1 meter, connector M12 male + female M8, 4-pole	Murrelektronik	PVC-OB 4x0,25mm2
+01-B15	1	1005663	Reflex sensor	Sick	GL6-P4211
+01-B15	1	1002242	Reflector	Sick	C42-2
+01-B15-W1	1	1003307	Prefab cable, PVC, 1 meter, connector M12 male + female M8, 4-pole	Murrelektronik	PVC-OB 4x0,25mm2
+01-U0	1	1003309	Passive plug-in terminal, 8-fold, 5-pole, M12	Murrelektronik	Exact12 8xM12 5-p
+01-U7	1	1003313	T-Coupler 5p Male M12 / 2x 4p Female M12, Distribution function	Murrelektronik	T-Coupler5p Male M12 / 2x 4p Female M12
+01-U7-W1	1	1003282	Prefab cable, PUR, 2 meter, connector M12 male 90°+ M12 female 90°, 4-pole	Murrelektronik	PUR-OB 4x0,34mm2
+02-M1	1		See specification sheet		
+03-M1	1		See specification sheet		

For technical specifications of gearmotor, applied options, machine configuration and other data see specification sheet.

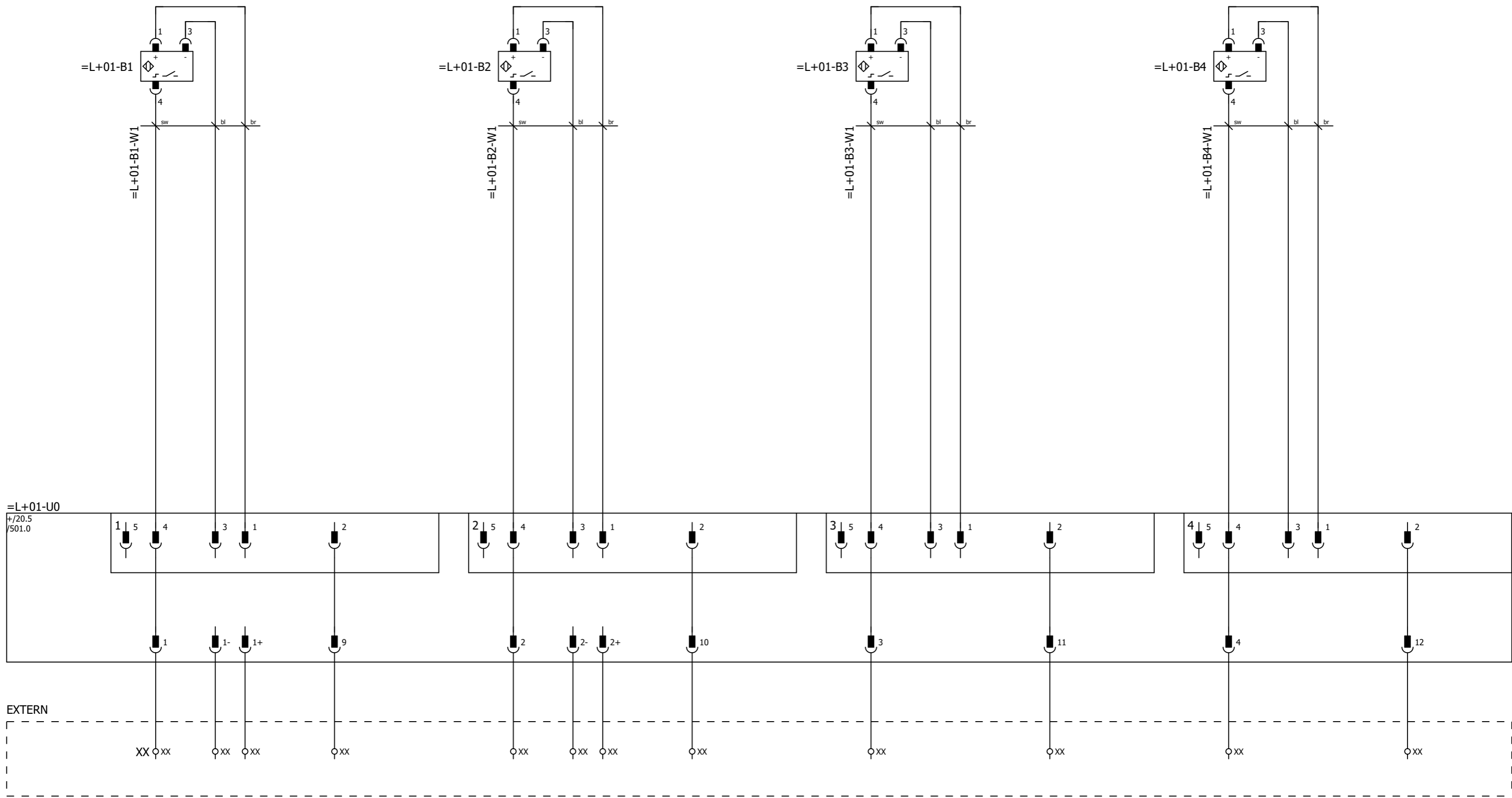

Passive plug-in terminal Belt driven conveyor BDC4 infeed

Wait position Spare Low speed to wait position Spare Low speed to infeed position Spare Infeed position Spare



Description of the project
PRmk5 (XL) Sorter conveyors
Standard

Page description
Field components

Mounting group BDC4 infeed
Mounting location Detection

Ed.	DSP	=	L
Date	20-12-2021	+	01
Version	v4.5.2		
		Page	500

For technical specifications of gearmotor, applied options, machine configuration and other data see specification sheet.

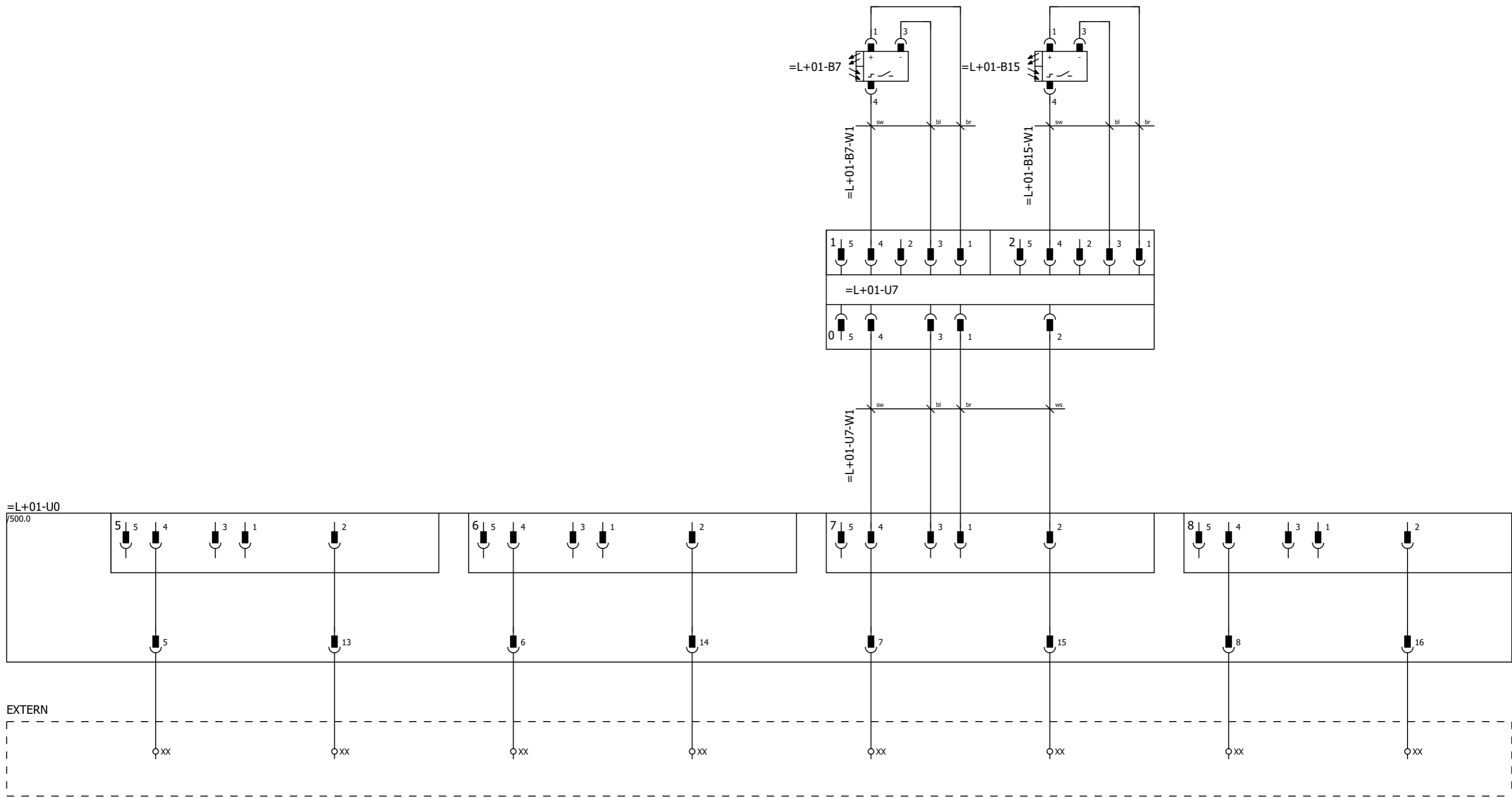

Passive plug-in terminal Belt driven conveyor BDC4 infeed Spare Spare Spare Spare Product on infeed Product position monitoring Spare Spare

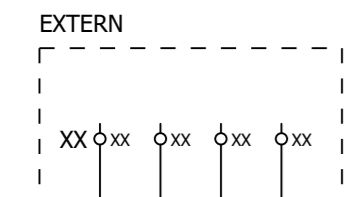

Connection gearmotor star

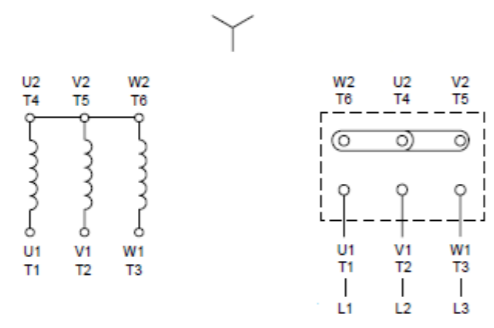

Connection gearmotor delta

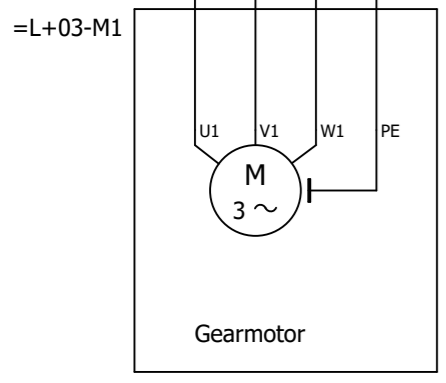
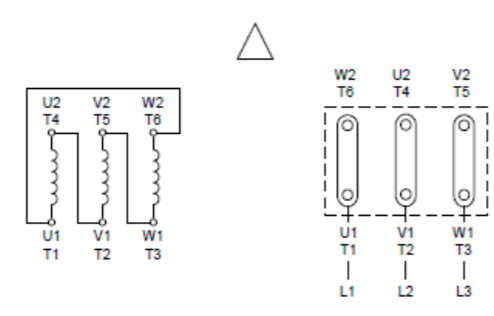

Gearmotor conveyor infeed

For technical specifications of gearmotor, applied options, machine configuration and other data see specification sheet.



Nobelstraat 43
3846 CE Harderwijk
The Netherlands

Phone: +31 341 - 436700
Fax: +31 341 - 436701
www.qimarox.com
info@qimarox.com

Document name: Electrical drawings PRmk5 (XL) Sorter conveyors v4.5.2
Mounting group: BDC4 outfeed
Type: Standard

Power supply: See specification sheet
Control voltage: 24VDC
According to: NEN-EN-IEC 60204-1: 2018

Version number: v4.5.2

Table of contents

Mounting group		Mounting location		Page	Page description
=M	BDC4 outfeed			1	Title page
				2	Table of contents
				10	Layout Belt driven conveyor BDC4 outfeed
				20	Overview passive plug-in terminal BDC4 outfeed
				2000	Parts list
		+01	Detection	500	Field components
		+01	Detection	501	Field components
		+02	Drive shuttle	150	Gearmotor, 3 fase
		+03	Drive conveyor	150	Gearmotor, 3 fase

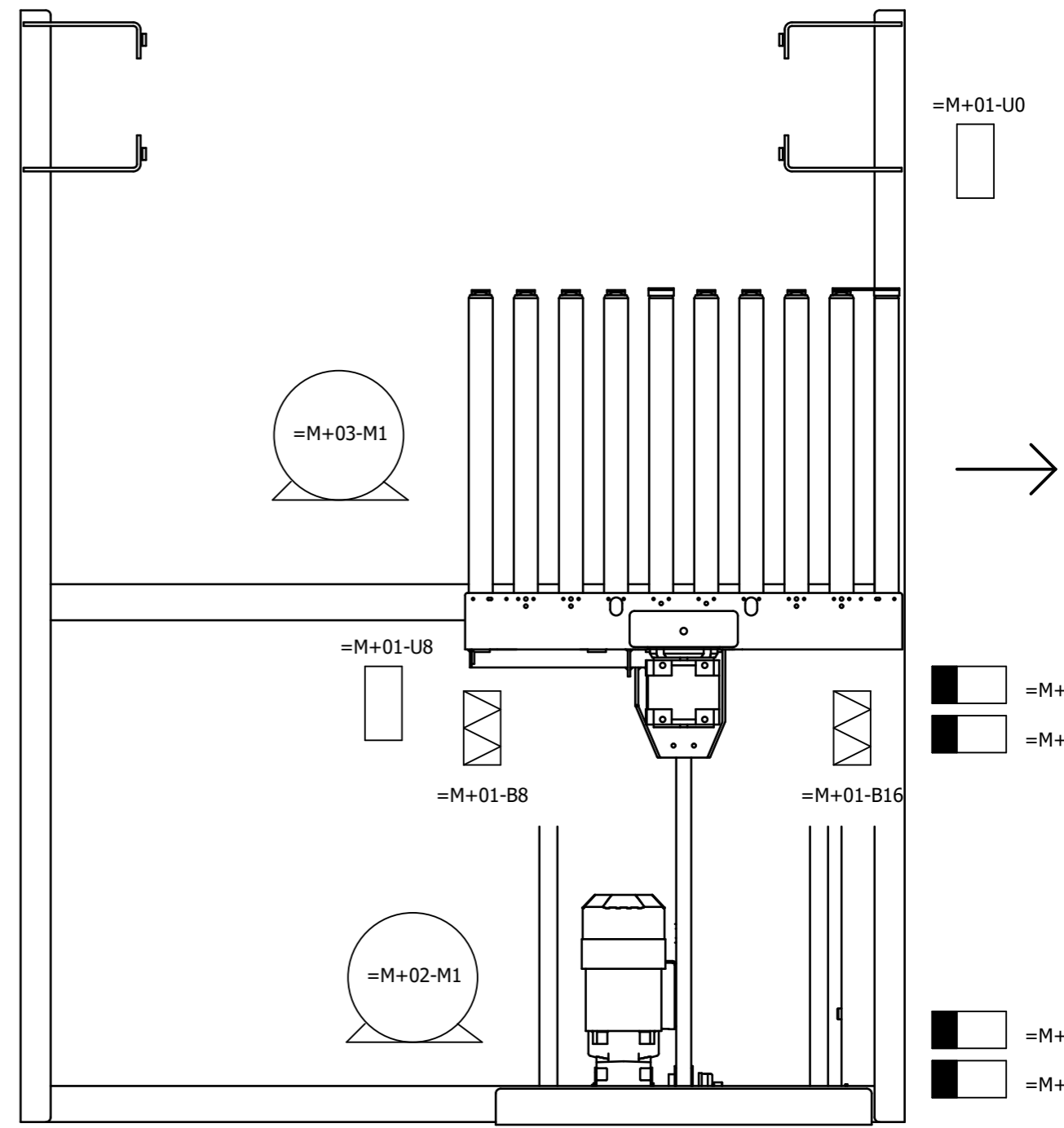
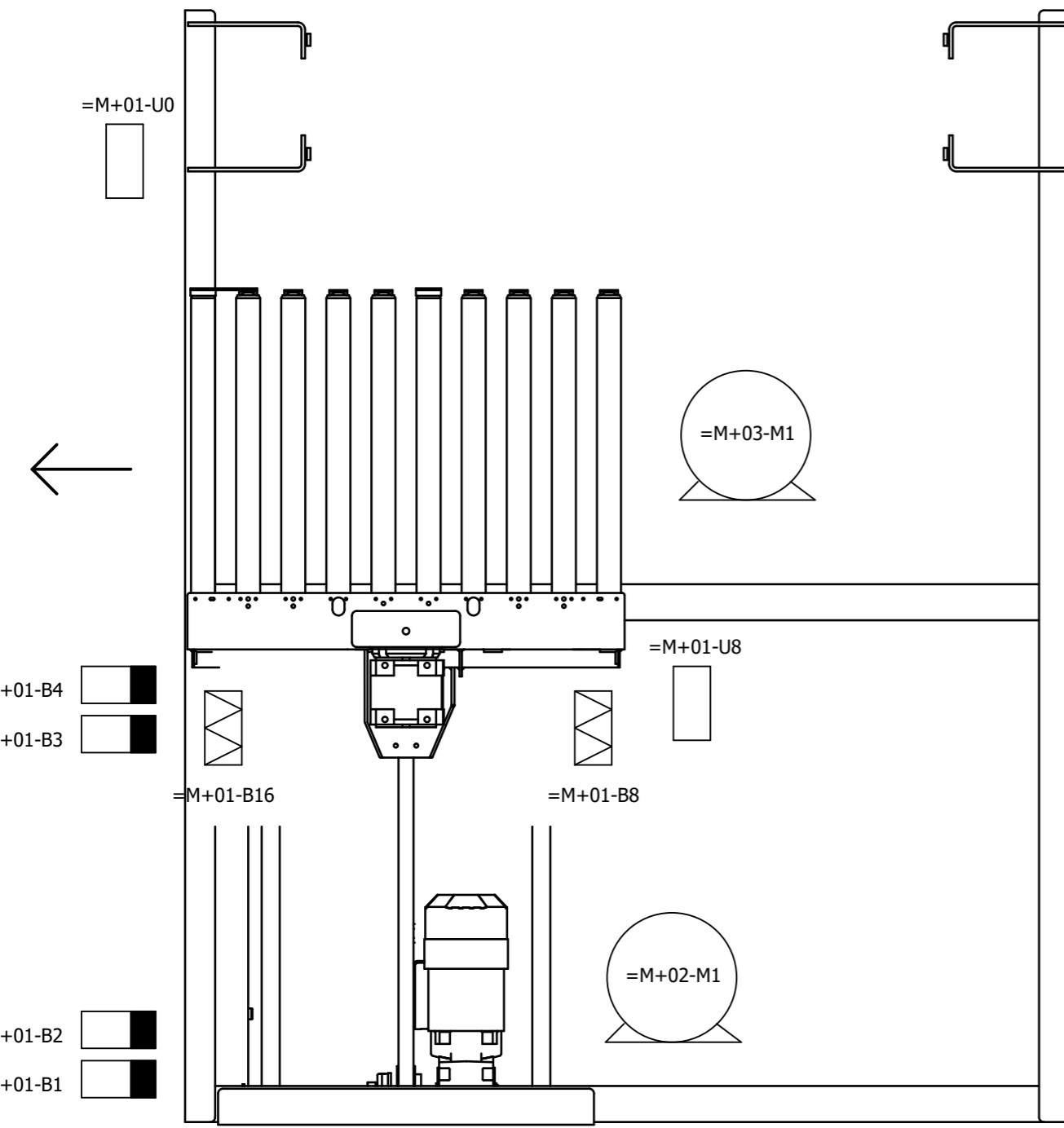

Legend:

- =M+02-M1 Gearmotor shuttle movement
- =M+03-M1 Gearmotor moveable outfeed conveyor

- =M+01-B1 Wait position
- =M+01-B2 Low speed to wait position
- =M+01-B3 Low speed to outfeed position
- =M+01-B4 Outfeed position
- =M+01-B8 Product on outfeed
- =M+01-B16 Product has left the outfeed

- =M+01-U0 Passive plug-in terminal Belt driven conveyor BDC4 outfeed
- =M+01-U8 T-coupler outfeed

For technical specifications of gearmotor, applied options, machine configuration and other data see specification sheet.

Image may differ from reality.

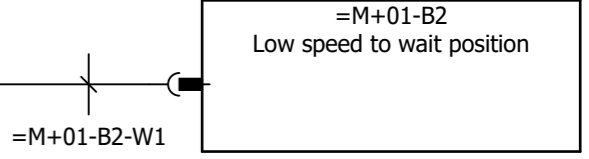
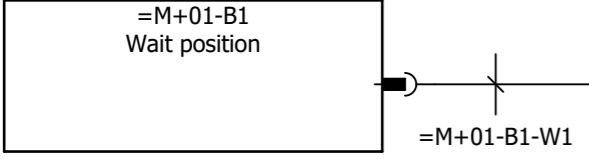
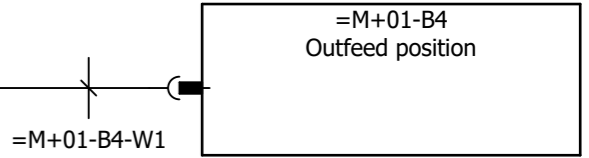
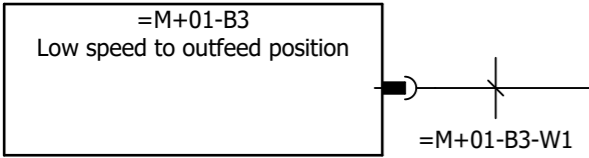
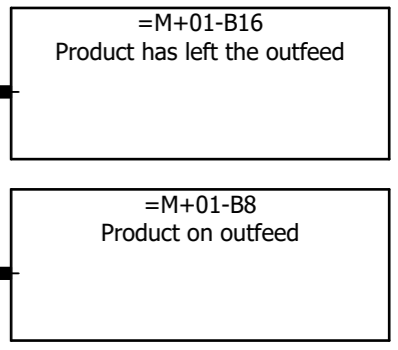
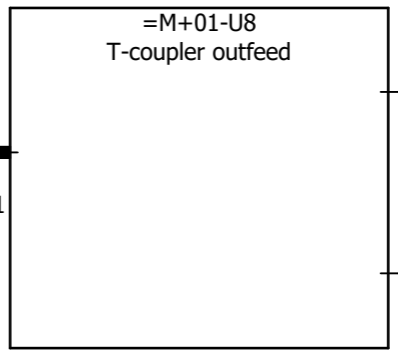
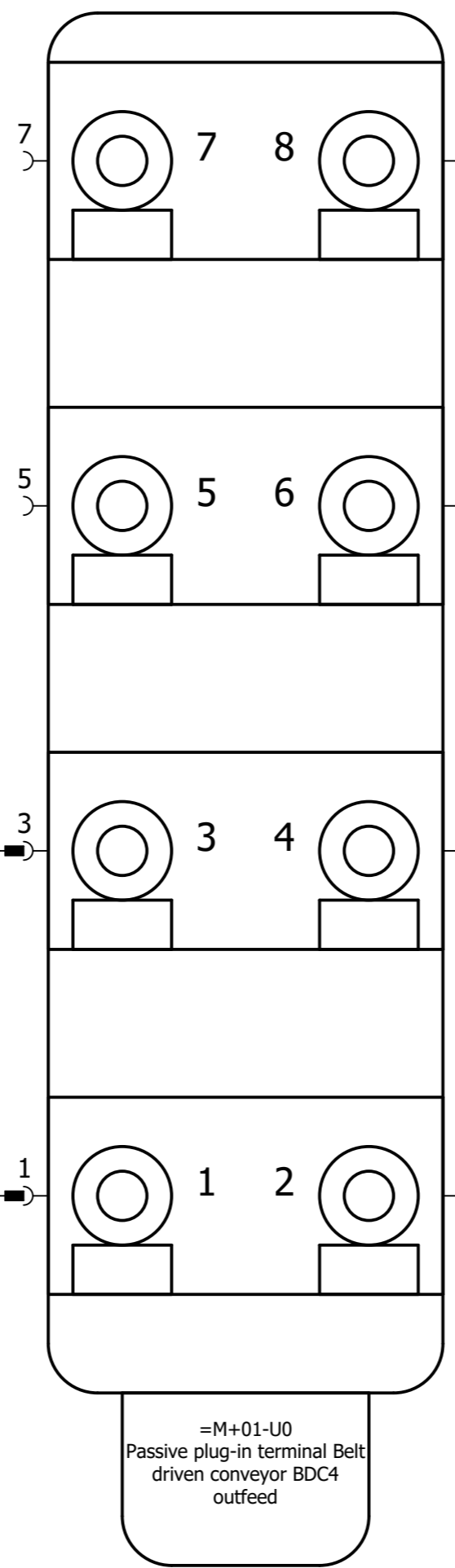

For technical specifications of gearmotor, applied options, machine configuration and other data see specification sheet.

Parts list

Position	Quantity	Article number	Description	Manufacturer	Type number
+01-B1	1	1000932	Inductive proximity sensor	Sick	IME18-08BPSZC0K
+01-B1-W1	1	1001528	Prefab cable, PVC, 2 meter, connector M12 male 90°+ M12 female 90°, 4-pole	Murrelektronik	PVC-OB 4x0,34mm2
+01-B2	1	1000932	Inductive proximity sensor	Sick	IME18-08BPSZC0K
+01-B2-W1	1	1001528	Prefab cable, PVC, 2 meter, connector M12 male 90°+ M12 female 90°, 4-pole	Murrelektronik	PVC-OB 4x0,34mm2
+01-B3	1	1000932	Inductive proximity sensor	Sick	IME18-08BPSZC0K
+01-B3-W1	1	1001601	Prefab cable, PVC, 1 meter, connector M12 male 90°+ M12 female 90°, 4-pole	Murrelektronik	PVC-OB 4x0,34mm2
+01-B4	1	1000932	Inductive proximity sensor	Sick	IME18-08BPSZC0K
+01-B4-W1	1	1001601	Prefab cable, PVC, 1 meter, connector M12 male 90°+ M12 female 90°, 4-pole	Murrelektronik	PVC-OB 4x0,34mm2
+01-B8	1	1005663	Reflex sensor	Sick	GL6-P4211
+01-B8	1	1002242	Reflector	Sick	C42-2
+01-B8-W1	1	1003307	Prefab cable, PVC, 1 meter, connector M12 male + female M8, 4-pole	Murrelektronik	PVC-OB 4x0,25mm2
+01-B16	1	1005663	Reflex sensor	Sick	GL6-P4211
+01-B16	1	1002242	Reflector	Sick	C42-2
+01-B16-W1	1	1003307	Prefab cable, PVC, 1 meter, connector M12 male + female M8, 4-pole	Murrelektronik	PVC-OB 4x0,25mm2
+01-U0	1	1003309	Passive plug-in terminal, 8-fold, 5-pole, M12	Murrelektronik	Exact12 8xM12 5-p
+01-U8	1	1003313	T-Coupler 5p Male M12 / 2x 4p Female M12, Distribution function	Murrelektronik	T-Coupler5p Male M12 / 2x 4p Female M12
+01-U8-W1	1	1003282	Prefab cable, PUR, 2 meter, connector M12 male 90°+ M12 female 90°, 4-pole	Murrelektronik	PUR-OB 4x0,34mm2
+02-M1	1		See specification sheet		
+03-M1	1		See specification sheet		

For technical specifications of gearmotor, applied options, machine configuration and other data see specification sheet.

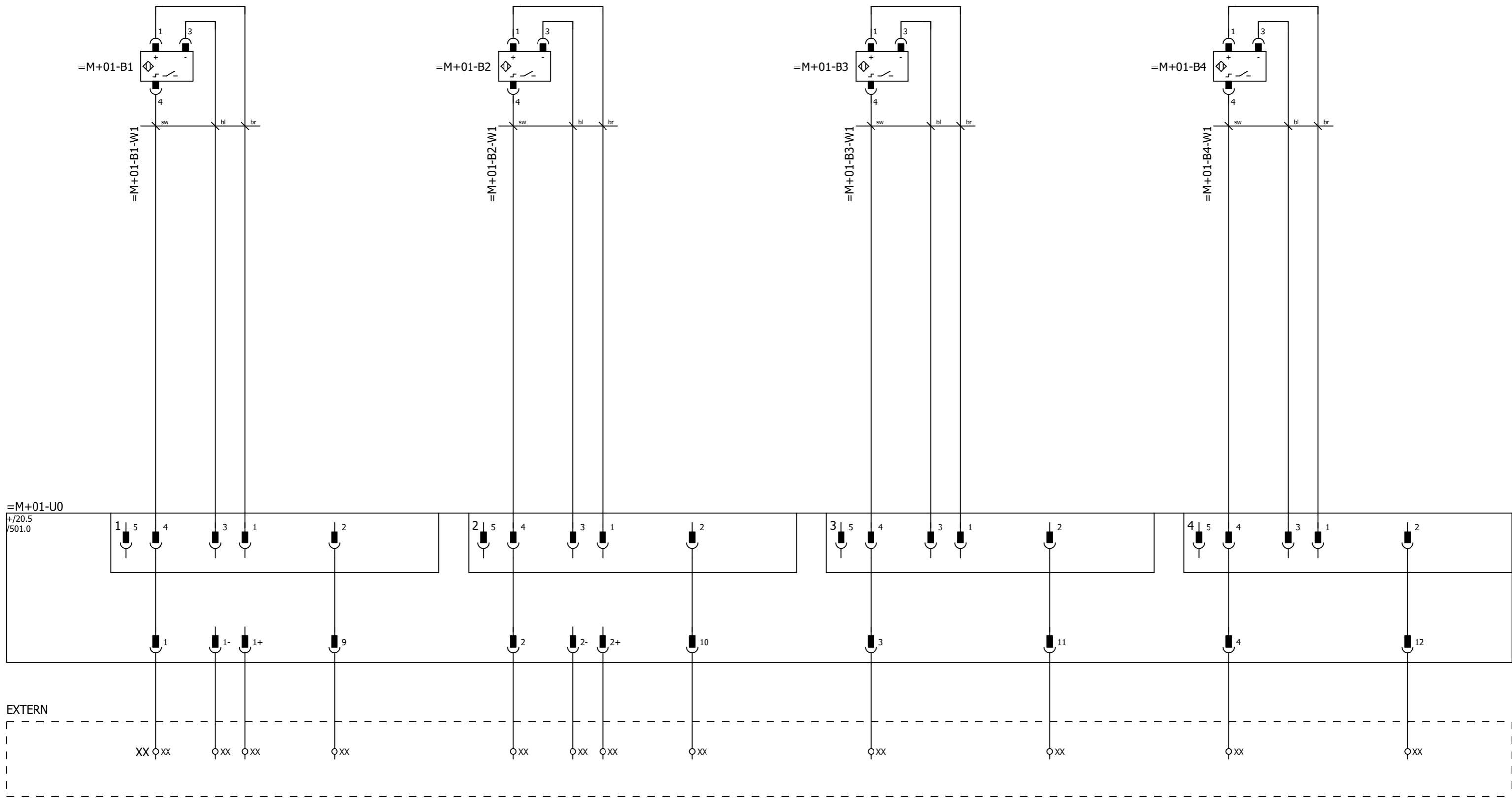

Passive plug-in terminal Belt driven conveyor BDC4 outfeed

Wait position Spare Low speed to wait position Spare Low speed to outfeed position Spare Outfeed position Spare



Description of the project
PRmk5 (XL) Sorter conveyors
 Standard

Page description
 Field components

Mounting group	BDC4 outfeed
Mounting location	Detection

Ed.	DSP	=	M
Date	20-12-2021	+	01
Version	v4.5.2		
			Page 500

For technical specifications of gearmotor, applied options, machine configuration and other data see specification sheet.

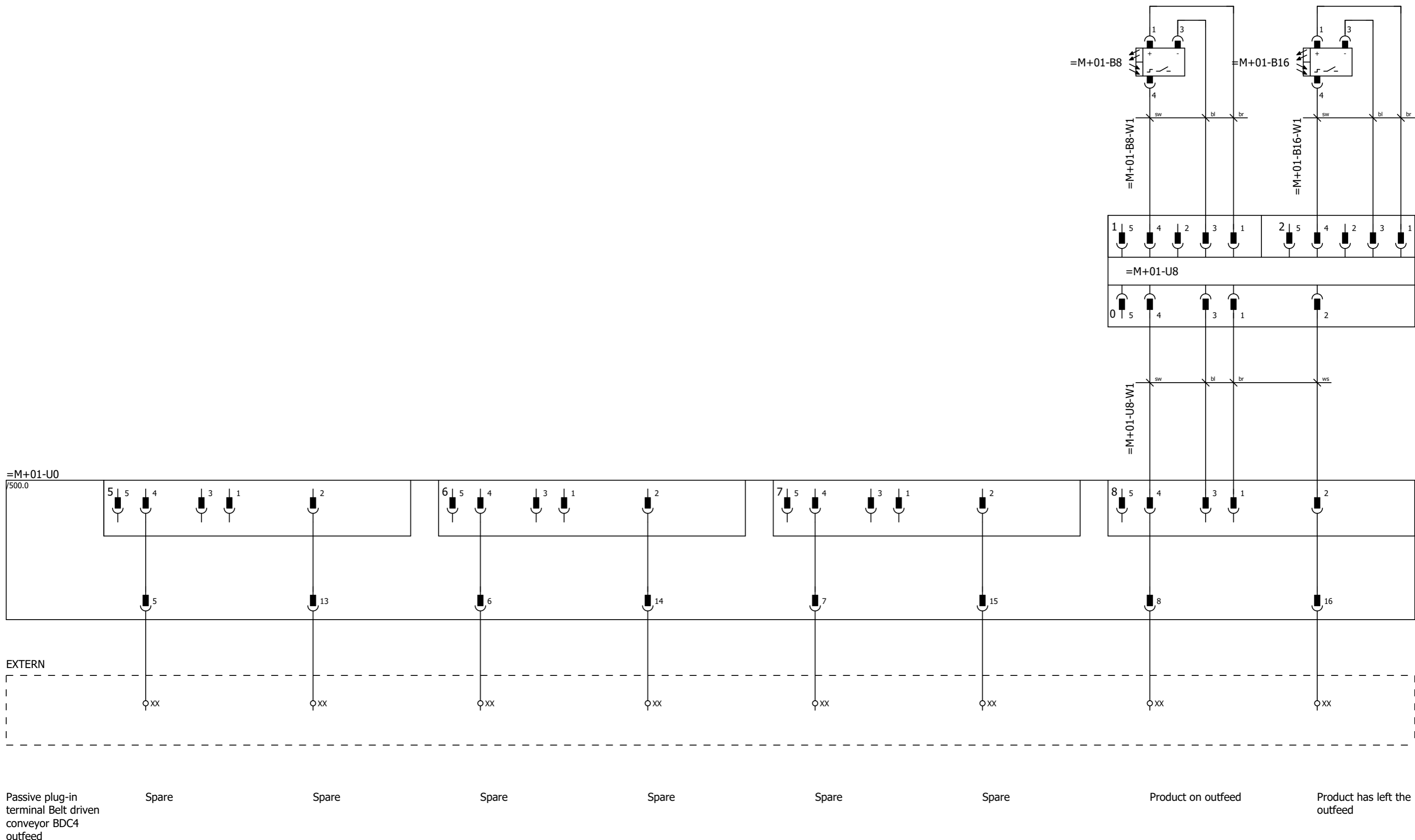

Passive plug-in terminal Belt driven conveyor BDC4 outfeed

Spare

Spare

Spare

Spare

Spare

Spare

Product on outfeed

Product has left the outfeed

EXTERN

Alternative

XX XX XX XX XX

XX XX

XX XX XX XX XX

XX XX XX

Connection gearmotor star

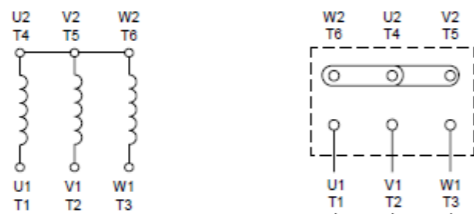

Connection gearmotor delta

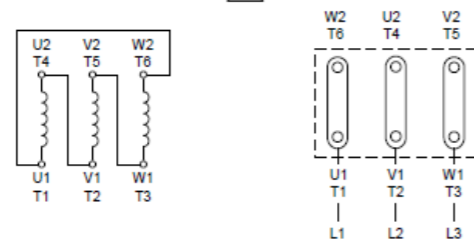

Connection thermistor

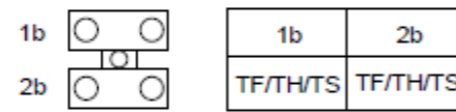

Connection brake 230VAC + 400VAC

Normal break reaction

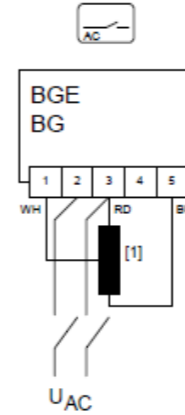

Rapid break reaction

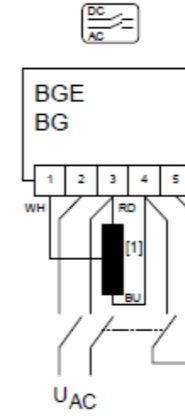

Connection brake 24VDC

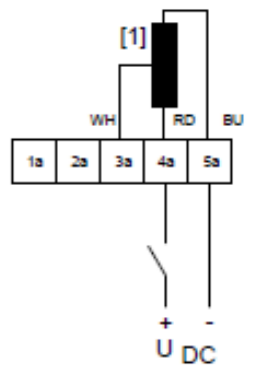

=M+02-M1

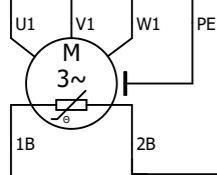

Gearmotor + thermistor

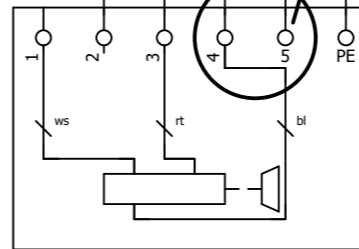

Brake 150...500VAC

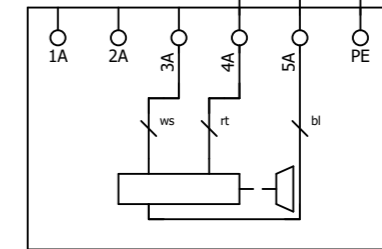

Brake 24VDC

Gearmotor shuttle movement

For technical specifications of gearmotor, applied options, machine configuration and other data see specification sheet.

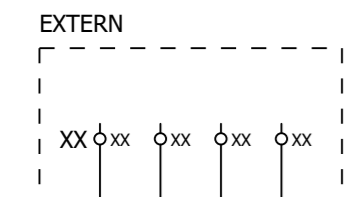

Connection gearmotor star

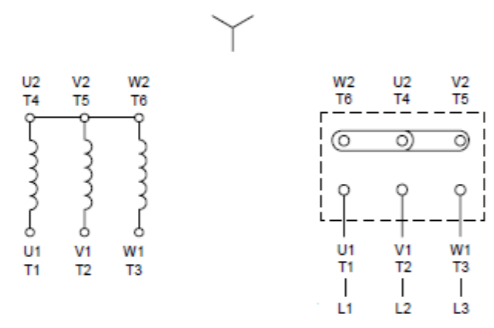

Connection gearmotor delta

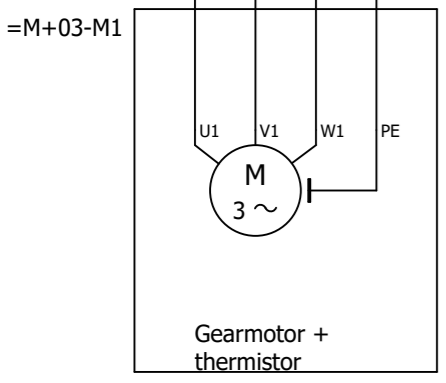
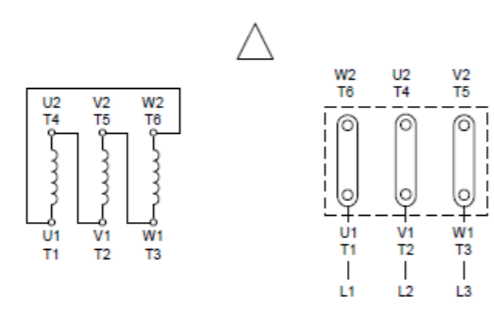

Gearmotor moveable
outfeed conveyor

For technical specifications of gearmotor, applied options, machine configuration and other data see specification sheet.