

Customer: \_\_\_\_\_

E-mail: \_\_\_\_\_

Product: \_\_\_\_\_

Product sizes: ..... x ..... x ..... inch.

Capacity: min. ....p/hour. max. ....p/hour.

Product weight: min. ....Lb. max. ....Lb.

Product orientation infeed \_\_\_\_\_

Product orientation outfeed: \_\_\_\_\_

Product infeed height: ..... inch.

Product outfeed height: ..... inch.

Conveyor included: Yes / No

Type of conveyor: Roller / Chain

Sensors included: Yes / No

Safety fencing: Yes / No

Safety fencing door: Yes / No

Operational: ..... / ..... / .....  
Hour / Day Days / Week

Lay-out: Send to info@Qimarox.com

Environment conditions: \_\_\_\_\_

Remarks: \_\_\_\_\_

\_\_\_\_\_

\_\_\_\_\_

\_\_\_\_\_

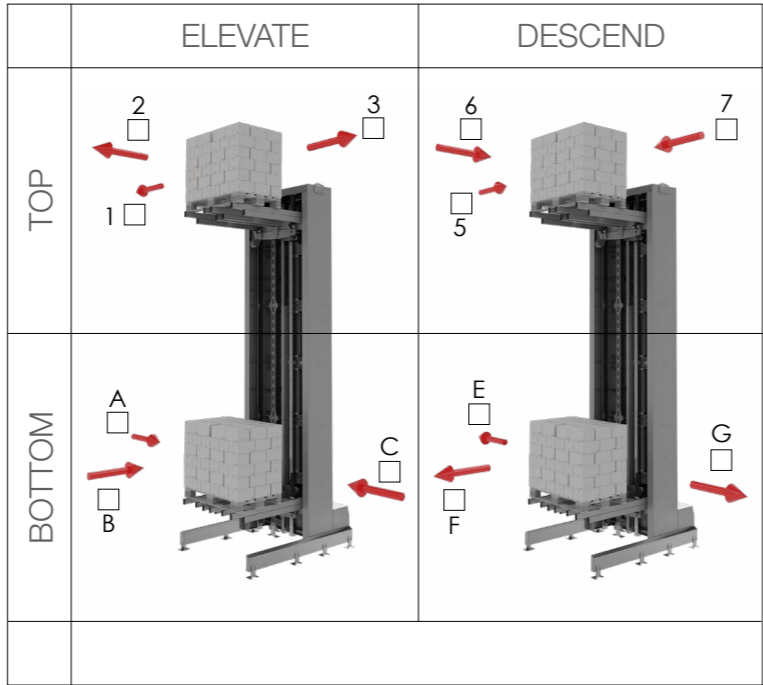
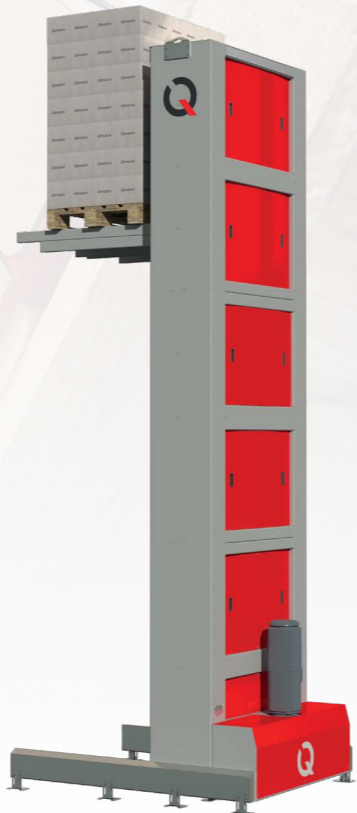

# PRORUNNER MK9 VERTICAL PALLET CONVEYOR



Key Components for material handling:

- Vertical Conveyors
- Palletizing Modules
- Sorting & Buffering
- Pallet Stackers
- Safety Fencing

Disclaimer: This document is for informational and promotional purposes only. All orders are subject to the Qimarox terms and conditions and Qimarox's written confirmation. Copyright © 2023 Qimarox

## Advantages of the Prorunner MK9

- Minimum footprint
- Suitable for multilevel vertical sorting
- Robust and low maintenance
- Drop down protection included
- No lubrication or chain tensing required
- Right-angle arrangement also possible
- Pallets, racks etc. up to 2,760 lb.
- Solid steel construction
- Drive motor at floor level
- Low noise

Specifications Qimarox Prorunner MK9		Basic model	Optional up to
Min. In / Outfeed	inch	20	20
Max. In / Outfeed	inch	105	420
Throughput	p/hour	60	Checked per RFQ
Product (Max. L x W)	inch	48 x 31	51 x 49
Weight	lb	2,200	2,760

\* Suitable for GMA pallets

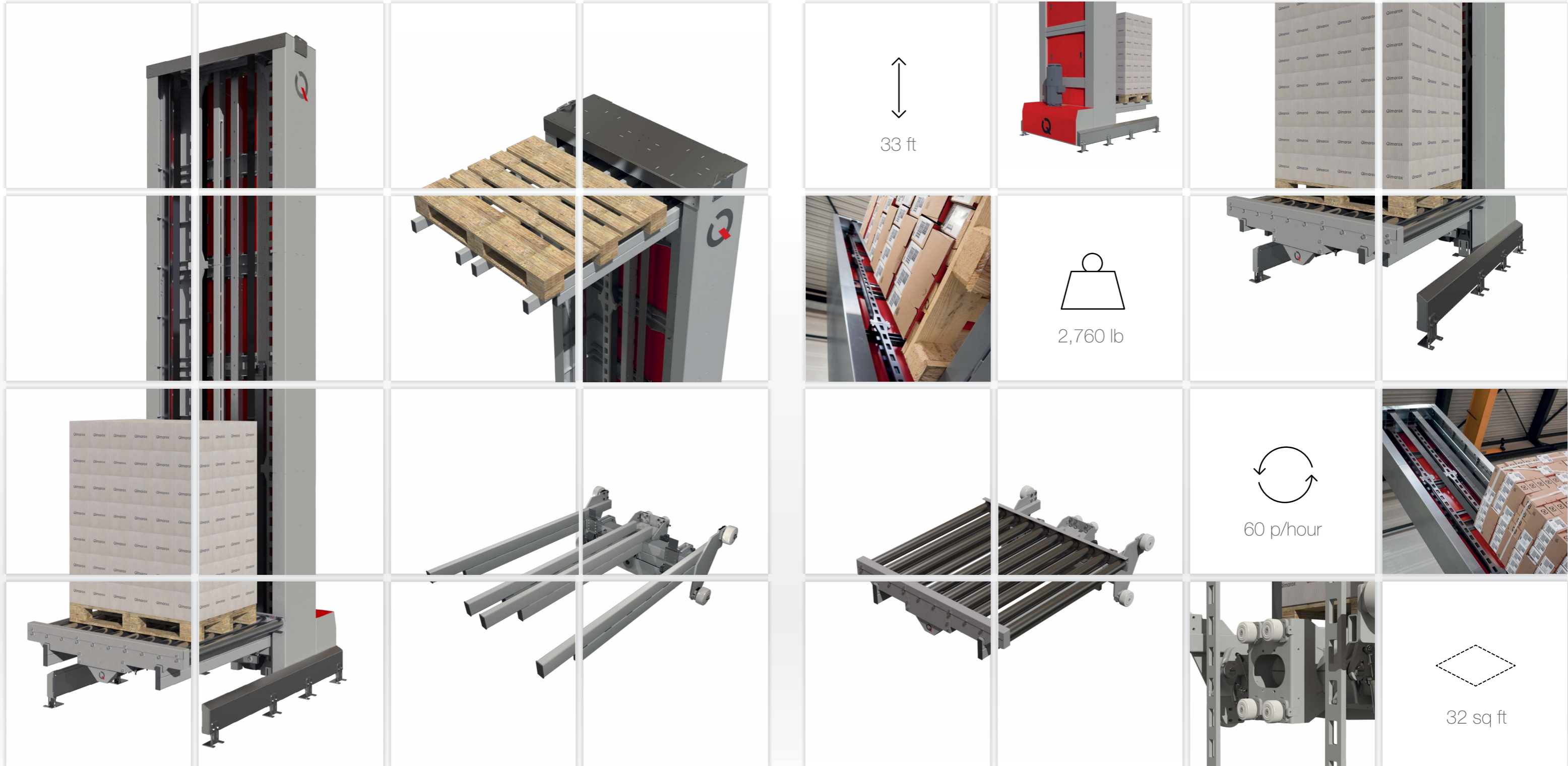

Key Components for material handling:

- Vertical Conveyors
- Palletizing Modules
- Sorting & Buffering
- Pallet Stackers
- Safety Fencing

Key Components for material handling:

- Vertical Conveyors
- Palletizing Modules
- Sorting & Buffering
- Pallet Stackers
- Safety Fencing