

Customer: _____

E-mail: _____

Product: _____

Product sizes: x xmm.

Capacity: min.p/hour. max.p/hour.

Product weight: min.Kg. max.Kg.

Product orientation infeed _____

Product orientation outfeed: _____

Product infeed height:mm.

Product outfeed height:mm.

Conveyor included: Yes / No

Type of conveyor: Roller / Chain

Sensors included: Yes / No

Safety fencing: Yes / No

Safety fencing door: Yes / No

Operational: / /
Hour / Day Days / Week

Lay-out: Send to info@Qimarox.com

Environment conditions: _____

Remarks: _____

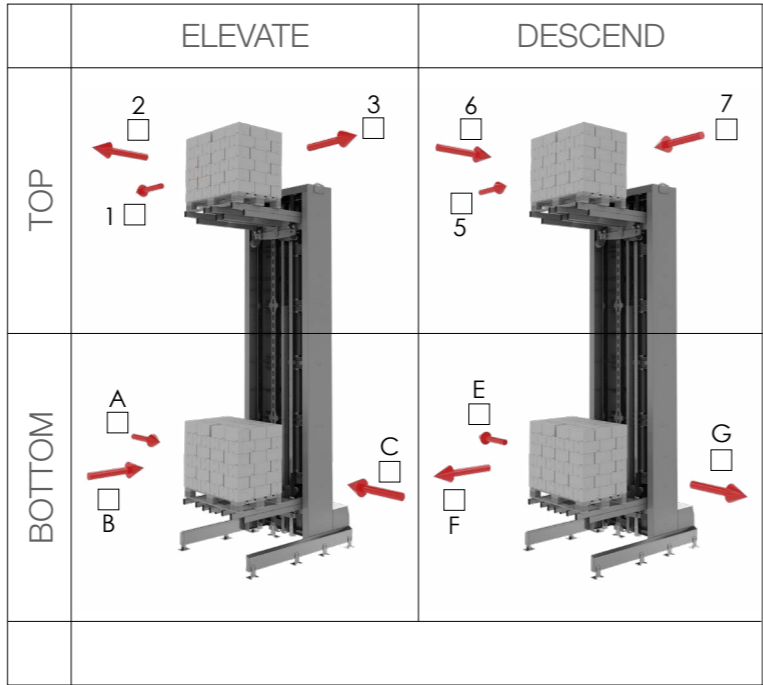
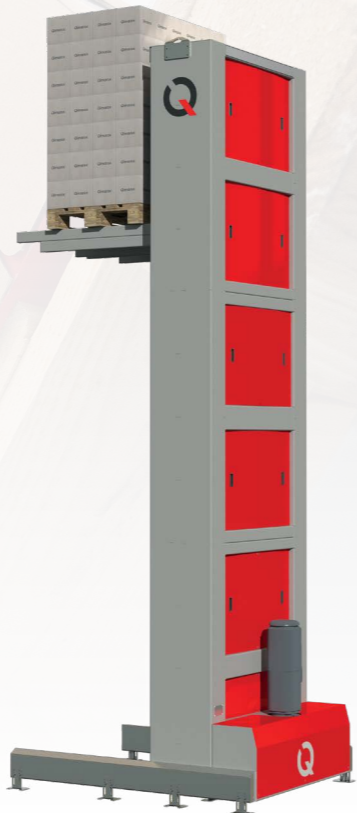

PRORUNNER MK9 VERTICAL PALLET CONVEYOR



Key Components for material handling:

- Vertical Conveyors
- Palletizing Modules
- Sorting & Buffering
- Pallet Stackers
- Safety Fencing

Disclaimer: This document is for informational and promotional purposes only. All orders are subject to the Qimarox terms and conditions and Qimarox's written confirmation. Copyright © 2023 Qimarox

Advantages of the Prorunner MK9

- Minimum footprint
- Suitable for multilevel vertical sorting
- Robust and low maintenance
- Drop down protection included
- No lubrication or chain tensioning required
- Right-angle arrangement also possible
- Pallets, racks etc. up to 1250 kg.
- Solid steel construction
- Drive motor at floor level
- Low noise

Specifications Qimarox Prorunner MK9		Basic model	Optional up to
Min. In / Outfeed	mm	500	500
Max. In / Outfeed	mm	2674	10,674
Throughput	p/hour	60	Checked per RFQ
Product (Max. L x W)	mm	1200 x 800	1300 x 1250
Weight	kg	1000	1250

* Suitable for GMA pallets

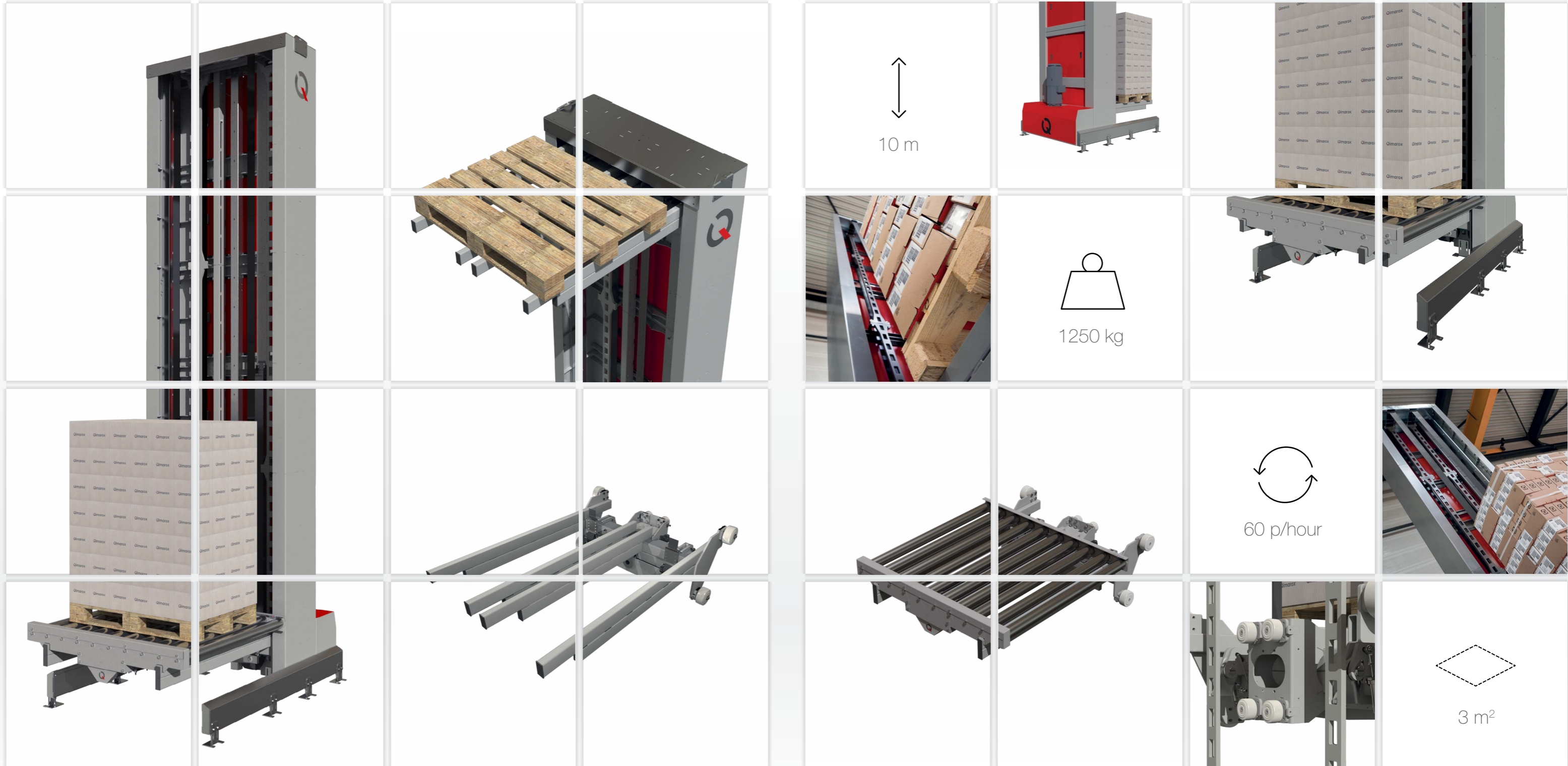

Key Components for material handling:

- Vertical Conveyors
- Palletizing Modules
- Sorting & Buffering
- Pallet Stackers
- Safety Fencing

Key Components for material handling:

- Vertical Conveyors
- Palletizing Modules
- Sorting & Buffering
- Pallet Stackers
- Safety Fencing