

Customer: _____

E-mail: _____

Product: _____

Product sizes: min. x x inch
 max. x x inch

Capacity: min. p/min. max. p/min.

Product weight: min. lb max. lb

Product orientation infeed: Short / Long Side Leading

Product orientation outfeed: Short / Long Side Leading

Product infeed height: inch

Product outfeed height: inch

Infeed conveyor: Driven / Gravity

Outfeed conveyor: Driven / Gravity

Sensors included: Yes / No

Safety fencing: Yes / No

Safety fencing door: Yes / No

Lay-out: Send to info@Qimarox.com

Environment conditions: _____

Remarks: _____

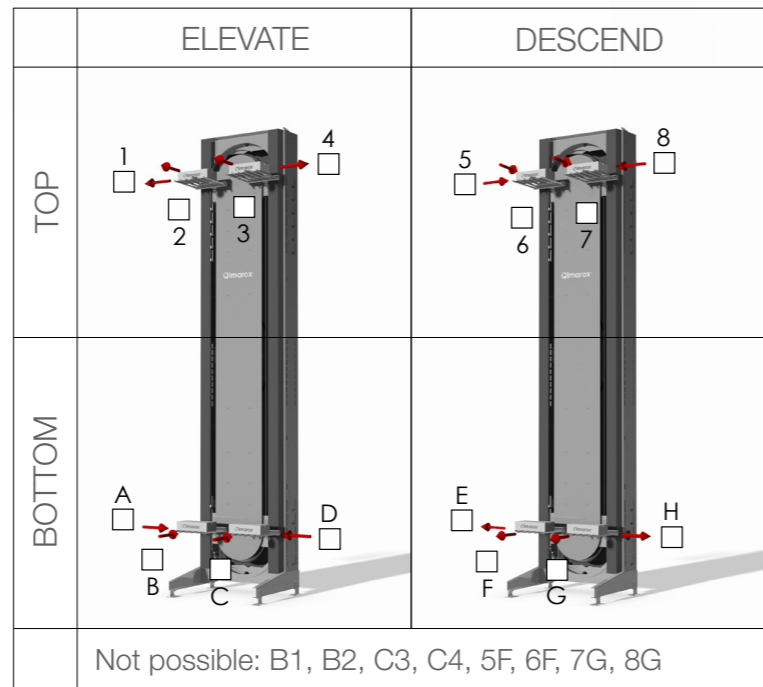

Suitable for

- Carton Trays • Bins • Tires • Books • Cardboard boxes • Shrink wrapped products • Soft parcels • Magazines
- Newspaper bundles • Frozen foods • Trays • Packaged bottles • Boxes • Bags • Totes

Disclaimer: This document is for informational and promotional purposes only.
 All orders are subject to the Qimarox terms and conditions and Qimarox's written confirmation. Copyright © 2023 Qimarox

Nobelstraat 43 NL-3846 CE Harderwijk The Netherlands Tel +31 341 - 436 700 USA Toll Free 877 778 83 75 info@Qimarox.com

www.Qimarox.com

PRORUNNER MK5
 PRORUNNER MK5-XL

VERTICAL CONVEYOR
 VERTICAL CONVEYOR

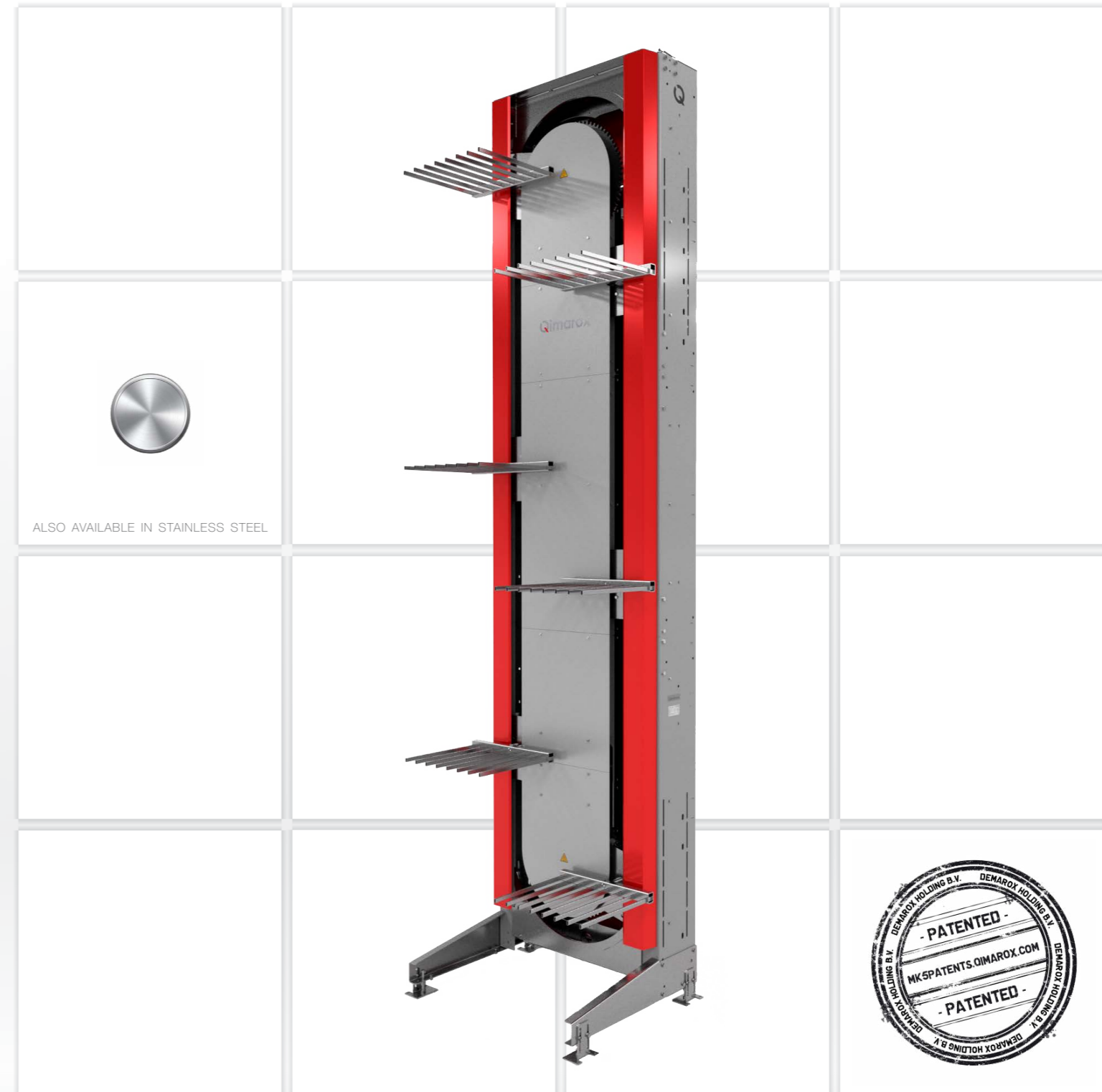

Key Components for material handling:

- Vertical Conveyors • Palletizing Modules • Sorting & Buffering • Pallet Stackers • Safety Fencing

www.Qimarox.com

Advantages of the PRORUNNER® MK5

- Line feed and cross feed
- No start-/stop movements
- Easy access to product carrier
- Possibility for in and out feed at multiple levels
- Number of carriers provide capacity (not speed)
- Can be used as vertical sorter
- No critical product transitions
- Drive system is protected inside the column
- C-lift or Z-lift configurations possible
- Can be used as a cross transfer
- Admits product infeed from side and front
- Carrier always remains horizontal
- Low noise

Specifications Qimarox Prorunner MK5 / MK5 XL	PR MK5 Basic	PR MK5 Optional up to	PR MK5 XL Basic	PR MK5 / XL Optional up to
Min. In / Outfeed	inch 23.60	23.60	31.95	31.95
Max. In / Outfeed	inch 98	757	111	682
Throughput	p/hour 400	2000	400	1650
Product (Max. L x W) *	inch 23.6 x 16.2	23.6 x 24	35.40 x 16.2	35.40 x 24
Weight	lb 25	50	44	110

* Length side always parallel to lift column (=SSL side in/outfeed, LSL front in/outfeed).



Key Components for material handling:

- Vertical Conveyors
- Palletizing Modules
- Sorting & Buffering
- Pallet Stackers
- Safety Fencing

Key Components for material handling:

- Vertical Conveyors
- Palletizing Modules
- Sorting & Buffering
- Pallet Stackers
- Safety Fencing