

Customer: \_\_\_\_\_

E-mail: \_\_\_\_\_

Product: \_\_\_\_\_

Product sizes: ..... x ..... x ..... inch.

Capacity: min. .... p/min. max. .... p/min.

Product weight: min. .... lb. max. .... lb.

Product orientation infeed: Short / Long Side Leading

Product orientation outfeed: Short / Long Side Leading

Product infeed: ..... inch

Product outfeed: ..... inch

Conveyor: Driven / Gravity

Sensors: Yes / No

Safety fencing: Yes / No

Safety fencing door: Yes / No

Operational: ..... / ..... | ..... / .....  
Hour / Day Days / Week

Lay-out: Send to info@Qimarox.com

Environment conditions: \_\_\_\_\_

Remarks: \_\_\_\_\_

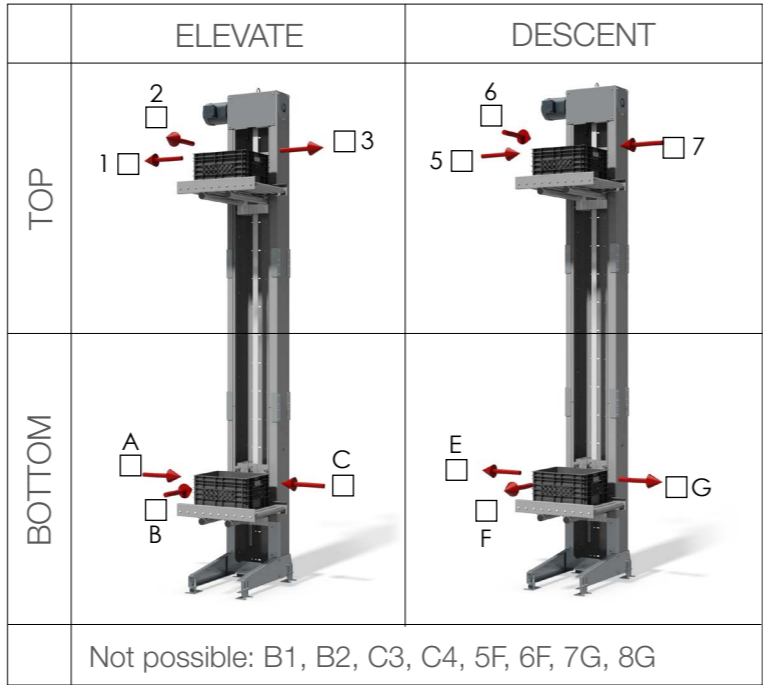

Suitable for

- Carton Trays • Bins • Tires • Books • Cardboard boxes • Shrink wrapped products • Soft parcels • Magazines
- Newspaper bundles • Frozen foods • Trays • Packaged bottles • Boxes • Bags • Totes

Disclaimer: This document is for informational and promotional purposes only.  
All orders are subject to the Qimarox terms and conditions and Qimarox's written confirmation. Copyright © 2023 Qimarox

Nobelstraat 43 NL-3846 CE Harderwijk The Netherlands Tel +31 341 - 436 700 USA Toll Free 877 778 83 75 info@Qimarox.com

[www.Qimarox.com](http://www.Qimarox.com)

# PRORUNNER MK1 VERTICAL PRODUCT CONVEYOR



ALSO AVAILABLE IN STAINLESS STEEL

Key Components for material handling:

- Vertical Conveyors • Palletizing Modules • Sorting & Buffering • Pallet Stackers • Safety Fencing

[www.Qimarox.com](http://www.Qimarox.com)

## Advantages of the PRORUNNER® MK1

- Minimum footprint
- Suitable for vertical sorting (several heights)
- Right-angle arrangement also possible
- Boxes, crates and bags up to 220 Lb.
- No lubrication or chain tensioning required
- Solid steel construction
- Robust and low maintenance
- Low noise level

Specifications Qimarox Prorunner MK1		Basic model	Optional up to
Min. In/Outfeed	inch	23.50	13.70
Max. In/Outfeed	inch	103	555
Throughput	p/hour	420	Checked per RFQ
Product (Max. L x W) *	inch	24 x 24	36 x 24
Weight	lb	66	220

\* Length side always parallel to the lift column (=SSL side in/outfeed).



Key Components for material handling:

- Vertical Conveyors
- Palletizing Modules
- Sorting & Buffering
- Pallet Stackers
- Safety Fencing

Key Components for material handling:

- Vertical Conveyors
- Palletizing Modules
- Sorting & Buffering
- Pallet Stackers
- Safety Fencing