

# Model TS1500-140

## Transnorm Belt Curve Conveyor

The Model TS1500-140 provides a positive flow of products by means of a belt, driven by tapered pulleys. Conveyor is versatile in that it can transport a wide variety of products. Available in 45°, 60°, 90°, and 180° turns. Other degrees available. Contact Transnorm.

- 15 Belt Widths
- Adjustable FSK-Type Floor Supports Available
- Clipper Lacing

F.O.B. Arlington, Texas



Conveyor shown with optional floor supports

**transnorm**  
your best move

**SLIDER BED**

OAW Frame	Conveying Surface Width	Belt Width	"IR"	"CL" Radius (CS)	"OR"	45° Weight (Lbs.)	60° Weight (Lbs.)	90° Weight (Lbs.)	180° Weight (Lbs.)
26-1/2"	21"	20"	36"	46-1/2"	57"	380	423	466	626
28-1/2"	23"	22"	34"	45-1/2"		388	438	487	659
30-1/2"	25"	24"	32"	44-1/2"		390	440	490	665
32-1/2"	27"	26"	54"	67-1/2"	81"	426	520	591	868
34-1/2"	29"	28"	52"	66-1/2"		428	524	596	877
36-1/2"	31"	30"	50"	65-1/2"		431	530	601	887
38-1/2"	33"	32"	48"	64-1/2"		434	533	606	896
40-1/2"	35"	34"	46"	63-1/2"		437	538	611	905
42-1/2"	37"	36"	44"	62-1/2"		439	542	616	913
44-1/2"	39"	38"	66"	85-1/2"	105"	481	621	706	1103
46-1/2"	41"	40"	64"	84-1/2"		485	627	713	1116
48-1/2"	43"	42"	62"	83-1/2"		488	633	720	1129
50-1/2"	45"	44"	60"	82-1/2"		491	639	726	1141
52-1/2"	47"	46"	58"	81-1/2"		494	644	732	1152
54-1/2"	49"	48"	56"	80-1/2"		497	649	738	1164

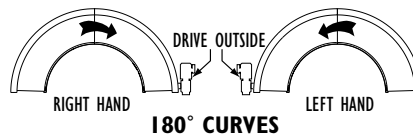
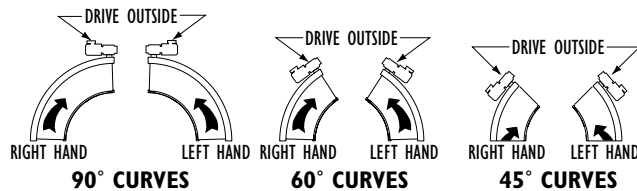
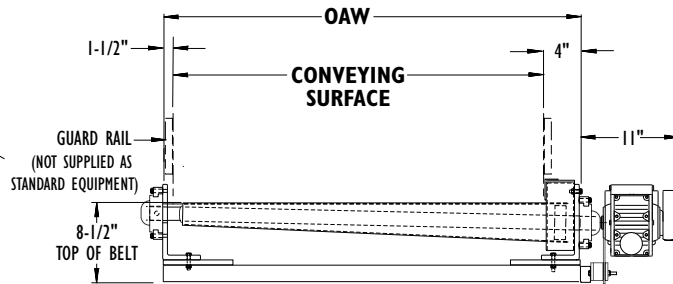
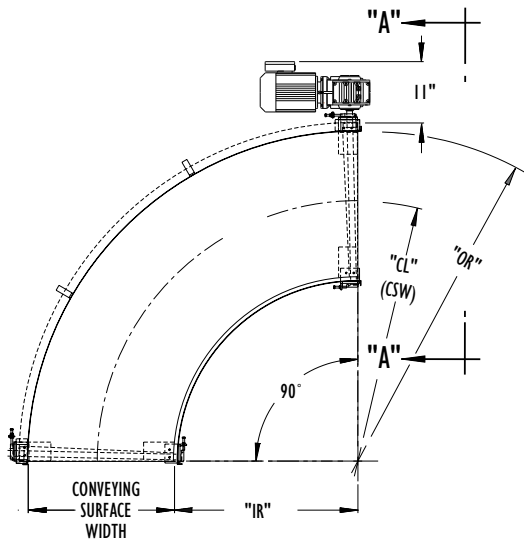

# • Standard Specifications

# Model TS1500-140

**BELT**—Black Monofilament, PVC top with urethane guide strip.

**FRAME**—9.45 in. deep x 40 mm x 40 mm aluminum extrusion.

**PULLEYS**—Tapered with 1-7/16 in. dia. shaft through bearings. Adjustable to control belt tension.

**BEARINGS**—Sealed, pre-lubricated, self-aligning, ball bearings on drive and tail pulley. Re-lube type.

**MOTOR**—3/4 HP Shaft Mounted Right Angle Gearmotor 208/230/460/575V-3Ph. 60 Hz (Specify Exact Voltage).

**BELT SPEED**—Constant 65 FPM at center line of conveying surface.

**CAPACITY**—Maximum load per linear foot (measured at center line of conveying surface) 40 lbs.

**FLOOR SUPPORTS**—Now supplied as optional equipment. See chart below for available elevations.

FSK SUPPORT		
Model No.	OAW	Adjustment to Top of Belt
FSK-1	26-1/2" to 30-1/2"	9-1/2" - 24"
FSK-2		24" - 30"
FSK-3		30" - 36"
FSK-4		36" - 42"
FSK-5		42" - 48"
FSK-6		48" - 54"
FSK-1	32-1/2" to 42-1/2"	9-1/2" - 24"
FSK-2		24" - 30"
FSK-3		30" - 36"
FSK-4		36" - 42"
FSK-5		42" - 48"
FSK-6		48" - 54"
FSK-1	44-1/2" to 54-1/2"	9-1/2" - 24"
FSK-2		24" - 30"
FSK-3		30" - 36"
FSK-4		36" - 42"
FSK-5		42" - 48"
FSK-6		48" - 54"

For elevations above 54", contact factory.

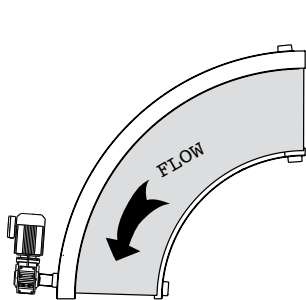

**TYPE A**  
LEFT HAND CURVE  
OUTSIDE DRIVE

STANDARD

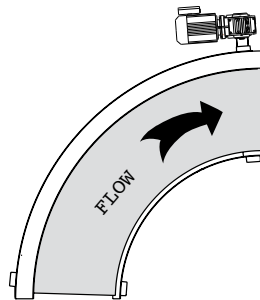

**TYPE B**  
RIGHT HAND CURVE  
OUTSIDE DRIVE

STANDARD

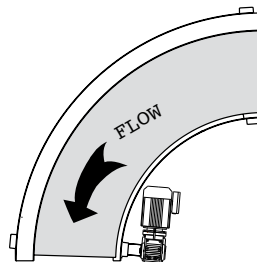

**TYPE C**  
LEFT HAND CURVE  
INSIDE DRIVE

STANDARD

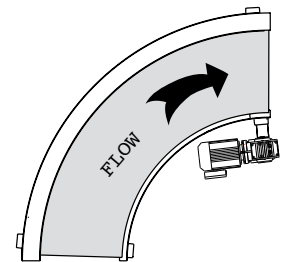

**TYPE D**  
RIGHT HAND CURVE  
INSIDE DRIVE

STANDARD

All locations are standard for Transnorm. Specify location.

## • Optional Equipment

**FLOOR SUPPORTS**—FSK Type floor supports are available with a wide range of adjustment. Specify top of belt elevation. Supports required at each end and in the center of the conveyor. Holes in feet for lagging to floor. Knee braces recommended above FSK-6 support.

**BELT SPEED**—Up to 250 FPM (shaft mounted), 251 - 600 FPM (timing belt),  
NOTE: Capacity affected with speed change, see chart above. Higher speeds available, contact factory.

**DRIVE LOCATION**—Specify.

**MOTORS**—Other HP available, 5 HP maximum (contact factory).

**BELTS**—Types and styles other than standard are available (contact factory).

**CEILING HANGERS**—Includes mouting brackets and cross pipes only.

**GUARD RAILS**—3 in. to 24 in. tall available for all sizes.

**ELECTRICAL CONTROLS**—Non-reversing magnetic starters and push-button stations. AC variable frequency drive.

**CUSTOM COLORS**—Available (contact factory). Paint chip must be provided.

