

MODEL 192CDLR

MEDIUM DUTY ROLL-TO-ROLL CHAIN DRIVEN LIVE ROLLER



Conveyor shown with optional supports

Roach model 192CDLR is a medium duty chain driven live roller conveyor. This conveyor is designed to transport loads such as tote pans, castings, drums or pallet loads.

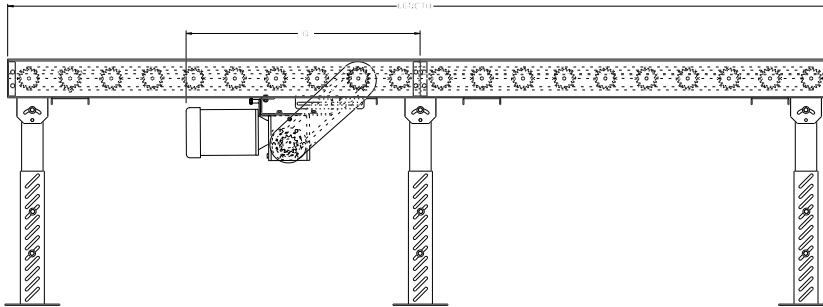
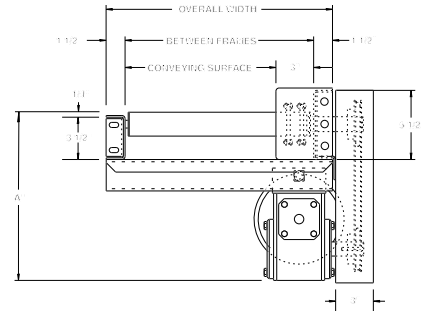

HP @ 45FPM	"A"	"B" MAX
1/3	13-1/8"	49-1/2"
1/2	13-1/8"	49-1/2"
3/4	13-1/2"	49-1/2"
1	13-3/4"	50-1/16"
1-1/2	14-5/8"	50-3/8"
2	15-1/2"	52-1/16"

SPECIFICATIONS

TREAD ROLLERS: 1.9" dia. x 12 ga. steel, model 192S with sprockets.

CHAIN DRIVE: Roll-to-roll no. 40 roller chain.

CENTER DRIVE: Reversible drive either side mounted or underside mounted (specify). Main drive roller is supported by precision, heavy duty, lubricated, ball bearing units.

CHAIN GUARD: The chain drive is completely enclosed along the entire length of the conveyor.

ROLLER CENTERS: 4", 6", 8" or 12" centers available.

SPEED: 45 FPM, constant.

BEARINGS: Removable type, zinc-plated, grease packed, labyrinth sealed.

BED: 5-1/2" x 1-1/2" x 10 ga. and 3-1/2" x 1-1/2" x 10 ga. formed steel channel frame.

MOTOR DRIVE: 1/3 HP, 230/460/3, 60 cycle, ODP right angle gear motor.

ELECTRICAL CONTROLS: Optional.



SPECIFICATION TABLE

■ 24 hour shipment

UNIT WEIGHTS (FOR 4" AND 8" ROLLER CENTERS ONLY)																				
CONVEYOR LENGTH		5'		10'		20'		30'		40'		50'		60'		70'		80'		
CONV. SURFACE	BF	4" RC	8" RC	4" RC	8" RC	4" RC	8" RC	4" RC	8" RC	4" RC	8" RC	4" RC	8" RC	4" RC	8" RC	4" RC	8" RC	4" RC	8" RC	
12"	15"	334	291	509	431	859	703	1209	948	1659	1247	1909	1519	1790	2065	2340				
18"	21"	372	319	572	474	969	773	1367	1073	1764	1372	2161	1671	1971	2276	2581				
24"	27"	409	351	634	516	1079	843	1524	1170	1969	1497	2414	1824	2251	2476	2801				
30"	33"	452	379	697	559	1190	914	1683	1269	2175	1623	2668	1978	2333	2688	3043				
36"	39"	469	406	739	600	1278	950	1817	1340	2356	1720	2895	2100	2480	2865	3250				
42"	45"	524	430	819	640	1407	1049	1994	1457	2581	1865	3169	2274	2684	3099	3514				
48"	51"	562	463	882	683	1517	1119	2152	1555	2788	1992	3423	2428	2864	3299	3734				

UNIT WEIGHTS (FOR 6" AND 12" ROLLER CENTERS ONLY)																			
CONVEYOR LENGTH		5'		10'		20'		30'		40'		50'		60'		70'		80'	
CONV. SURFACE	BF	6" RC	12" RC	6" RC	12" RC	6" RC	12" RC	6" RC	12" RC	6" RC	12" RC	6" RC	12" RC	6" RC	12" RC	6" RC	12" RC	6" RC	12" RC
12"	15"	307	285	457	405	755	651	1053	897	1351	1143	1647	1389	1946	1634	2246	1884	2546	2134
18"	21"	341	301	506	441	837	707	1169	974	1500	1240	1831	1506	2163	1773	2493	2043	2823	2313
24"	27"	370	331	555	476	921	763	1287	1050	1653	1337	2019	1624	2385	1911	2755	2201	3125	2491
30"	33"	405	358	605	513	1006	822	1407	1131	1807	1439	2208	1748	2609	2057	3009	2367	3409	2677
36"	39"	418	363	633	528	1066	856	1499	1184	1932	1512	2365	1840	2798	2168	3228	2498	3658	2828
42"	45"	465	406	700	581	1169	931	1637	1280	2105	1629	2574	1979	3044	2330	3514	2680	3984	3030
48"	51"	499	432	749	617	1251	987	1753	1357	2256	1728	2753	2090	3260	2468	3760	2838	4260	3208

OPTIONAL EQUIPMENT

SPEED: Constant speed 1.5-100 FPM; DC variable speed; AC inverter variable speed. Other constant or variable speeds available. **NOTE: CAPACITY CHANGES WITH SPEED. 100 FPM MAX. WITH ROLL-TO-ROLL CHAIN DRIVE.**

MOTORS: Available through 3 HP in TEFC, explosion proof, dirty duty, brake motor, 115/230/1, 575/3, etc.

FLOOR SUPPORTS: Supports, knee braces, casters and polytler supports available. See Conveyor Accessories.

UNDERTRUSSED BED: Available to provide clearance underneath unit at bed joint locations. Specify location for undertrussing and desired clearance underneath unit. Consult factory.

GUARD RAILS: 1-3/4" x 1" formed channel (model GC), adjusts horizontally to 8" wider than roller and vertically to 6" above roller; formed steel fixed (model FSG in 2", 4" and 6" heights; fixed channel (model FC); 1-1/2" angle (model GA1-1/2). See Conveyor Accessories.

CEILING HANGERS: 5/8" dia. threaded rod with hardware to attach rods to conveyor. Provides 6' clearance between ceiling and TOR (furnished in place of floor supports). See Conveyor Accessories.

ELECTRICAL CONTROLS: Magnetic starter; one direction manual starter; momentary start/stop push button station; limit switch, photo relay; others available.

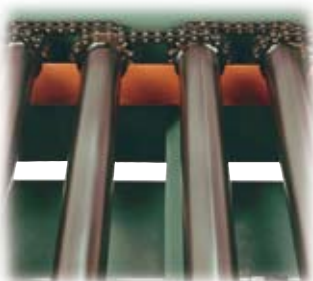

ROLLER TO ROLLER CHAIN DRIVE
(guard removed for clarity)



OPTIONAL TOP ROLLER GUARD MOUNTED DRIVE



MODEL 192CDLRC MEDIUM DUTY CHAIN DRIVEN LIVE ROLLER CURVE



Conveyor shown with optional supports

Roach 192CDLRC is a medium duty chain driven live roller curve, designed to transport medium duty loads such as castings or drums. NOTE: When conveying medium duty pallet loads, use model 254CDLRC, opposite page, to maintain product orientation.

SPECIFY MODEL NUMBER PER EXAMPLE
192CDLRC-27-45-L
 192CDLRC-(between frames)-(degree)-(left or right)

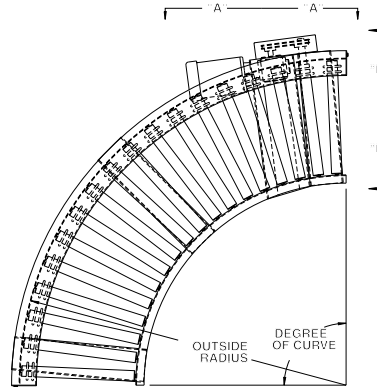
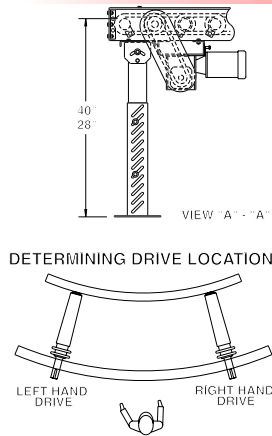
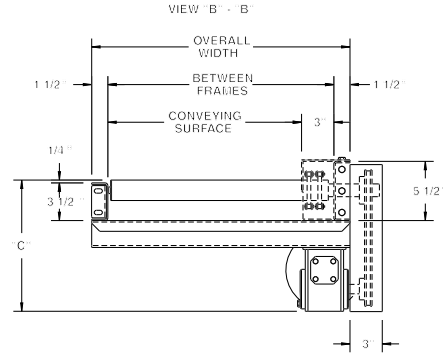

UNIT		90°		45°		
BF	CONV. SURFACE	OUTSIDE RADIUS	QTY. RLRS.	WT (lbs.)	QTY. RLRS.	WT. (lbs.)
15"	12"	4'-10-3/4"	18	339	9	265
21"	18"	4'-10-3/4"	18	374	9	277
27"	24"	4'-10-3/4"	18	409	9	292
33"	30"	8'-15/16"	30	543	15	313
39"	36"	8'-15/16"	30	586	15	337
45"	42"	8'-15/16"	30	633	15	364
51"	48"	8'-15/16"	30	681	15	391

SPECIFICATIONS

TREAD ROLLERS: 1.9" dia. x 12 ga. steel, model 192S with sprockets.*

CHAIN DRIVE: Roller to roller with No. 40 circular roller chain.

END DRIVE: Reversible drive either side mounted or underside (specify). Main drive roller is supported by precision, heavy duty, lubricated, ball bearing units.

CHAIN GUARD: Chain drive is enclosed, top and bottom, along entire length of conveyor.

BED: 5-1/2" x 1-1/2" x 10 ga. and 3-1/2" x 1-1/2" x 10 ga. formed steel channel frame.

BEARINGS: Removable type, heavy duty bearings, zinc plated, grease packed, labyrinth sealed.

MOTOR DRIVE: 1/3 HP, 230/460/3, 60 cycle, ODP right angle gear motor.

SPEED: 45 FPM, constant.

DRIVE LOCATION: Drive located on outside of curve. Specify right hand drive or left hand drive (drive hand determined with reference point located at outside of curve).

ROLLER CENTERS: 5" RC measured at outside radius of curve.

ELECTRICAL CONTROLS: Optional.

HP @ 45FPM	"C"
1/3, 1/2	13-1/8"
3/4	13-1/2"
1	13-3/4"
1-1/2	14-5/8"
2	15-1/2"

OPTIONAL EQUIPMENT

SPEED: Constant speed 1.5-60 FPM; DC variable speed; AC inverter variable speed. Other constant or variable speeds available.
NOTE: CAPACITY CHANGES WITH SPEED. 100 FPM MAX. WITH ROLLER-TO-ROLLER CHAIN DRIVE.

MOTORS: Available through 3 HP in TEFC, explosion proof, dirty duty, 115/230/1, 575/3, etc.

FLOOR SUPPORTS: Supports, knee braces, casters, ceiling hangers and polytier supports available. See Conveyor Accessories.

ELECTRICAL CONTROLS: Magnetic or manual starter; limit switch; others available.

*NOTE: Orientation of product may be affected because of straight rollers in curve. To maintain orientation, use tapered roller curve.



■ 4 week shipment